

**X STD SCIENCE PRACTICAL GUIDE 2022 – 2023**

Prepared by  
**M.G.RAYMOND, M.Sc., B.Ed.,**  
**ST.PAUL'S MAT. HR. SEC. SCHOOL,BLOCK – 4, NEYVELI -607801.**  
**9629705161 / 9442980841 raymondmg2001@gmail.com**

INDEX				
EX. NO.	DATE	TITLE	PAGE NO.	SIGN.
<b>I. PHYSICS</b>				
1.		Determination of weight of an object using the principle of moments		
2.		Determination of focal length of a convex lens.		
3.		Determination of resistivity.		
<b>II. CHEMISTRY</b>				
1.		Identification of the dissolution of the given salt whether it is exothermic or endothermic.		
2.		Testing the solubility of the salt.		
3.		Testing the water of hydration of salt.		
4.		Test the given sample for the presence of acid or base.		
<b>III. BIO - BOTANY</b>				
1.		TEST TUBE AND FUNNEL EXPERIMENT		
2.		PARTS OF A FLOWER		
3.		STUDY OF LAW OF DOMINANCE		
4.		MICRO SLIDE – T.S OF DICOT STEM		
5.		MICRO SLIDE – T.S OF DICOT ROOT		
<b>IV. BIO - ZOOLOGY</b>				
1.		MODEL – HUMAN HEART		
2.		MODEL – HUMAN BRAIN		
3.		MICRO SLIDE – RED BLOOD CELLS		
4.		MICRO SLIDE – WHITE BLOOD CELLS		
5.		MODEL – THYROID GLAND		
6.		MODEL – PANCREAS (ISLETS OF LANGERHANS)		

**INSTRUCTIONS**

- Use pencil to draw diagrams and tables. Use pen to label the diagrams and to fill the data in tables.
- Diagrams and tables should come in left side of the record note. Content of each exercise should be written in right side of the record note with pen.
- One question each from Physics, Chemistry, Botany and Zoology will be asked in Government Public Exam.
- Mark allotment

Physics	1 X 5 = 5
Chemistry	1 X 5 = 5
Botany	1 X 5 = 5
Zoology	1 X 5 = 5
Record Note	= 5

---

25 Marks

---

## I. PHYSICS

### 1. DETERMINATION OF WEIGHT OF AN OBJECT USING THE PRINCIPLE OF MOMENTS.

**Aim:**

To determine the weight of an object using the principle of moments

Apparatus required – 1 Mark
Procedure – 1 Mark
Observation – 2 Marks
Result – 1 Mark

**Apparatus required:**

A metre scale, a knife edge, slotted weights, thread

**Procedure:**

- i. A metre scale is supported at its centre of gravity by a knife edge or suspended by using a thread tied to its centre so that the scale is in the horizontal position. Ensure that the scale is in equilibrium position.
- ii. A known weight  $W_2$  and an unknown weight  $W_1$  are suspended from to either side of the the scale using the weight hangers.
- iii. Fix the position of one weight hanger and adjust the position of the second weight hanger such that the scale is in equilibrium.
- iv. Measure the distance  $d_1$  and  $d_2$  of the two weight hangers from the centre of the scale accurately.
- v. The experiment is repeated for different positions of the unknown weight. Measure the distances. The reading are tabulated as follows:

S.No.	Weight in the weight hanger( $W_2$ ) kg	Distance of known weight $d_1$ (m)	Distance of unknown weight $d_2$ (m)	$W_2 \times d_2$ (kg m)	Unknown weight $W_1 = W_2 \times d_2/d_1$ (kg)
1.	0.1	0.1	0.2	0.02	0.2
2.	0.1	0.15	0.3	0.03	0.2
3.	0.1	0.2	0.4	0.04	0.2
Mean					0.2

**Calculations:**

Moment of a force can be calculated using the formula

Moment of the force = Force x distance

Clock wise moment by unknown weight =  $W_1 \times d_1$

Anticlockwise moment by known weight =  $W_2 \times d_2$

$$W_1 \times d_1 = W_2 \times d_2$$

$$W_2 \times d_2$$

$$\text{Unknown weight} = W_1 = \frac{W_2 \times d_2}{d_1}$$

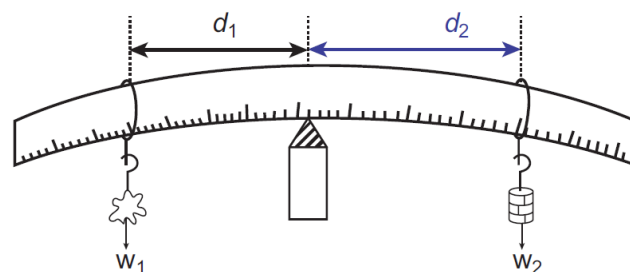

**Result:** Using the principle of moments, the weight of the unknown body  $W_1 = 0.2 \text{ Kg Wt.}$

### 2. DETERMINATION OF FOCAL LENGTH OF A CONVEX LENS

**Aim:**

To determine the focal length of a convex lens by using

1. Distant object method
2. uv method

**Apparatus required:** A convex lens, stand, wire gauze object, screen and measuring scale.

**Formula:**

$$f = \frac{uv}{(u + v)} \text{ cm}$$

Here,

$u$  is the distance between the object (light source) and the convex lens

$v$  is the distance of the image (screen) from the convex lens

$f$  is the focal length of the convex lens

Formula – 1 Mark
Procedure – 1 Mark
Diagram – 1 mark
Table – 1 Mark
Result – 1 Mark

**1. Distant Object Method:**

Fix the given convex lens vertically on the stand and place it on the table near an open window of the laboratory. Locate a distant object (tree or building) through the open window. Place the screen behind the convex lens. Adjust the position of the convex lens and the screen so as to get a sharp, inverted and diminished image. Measure the distance between the screen and the convex lens with the help of the measuring scale. This distance is equal to the approximate focal length of the convex lens (f).

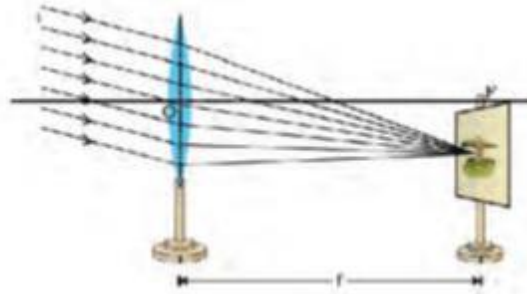

**2. uv - Method:**

Fix the given convex lens vertically on the stand and place it on the table. Place the wire gauze object on the left side of the convex lens (say at a distance greater than 2f). Measure the distance between the object and the lens (u). Place the screen on the right side of the convex lens and adjust its position to get a sharp, inverted and diminished image. Measure the distance between the screen and the lens (v). Repeat the same procedure, by changing the distance of the object (u) and tabulate your observations.

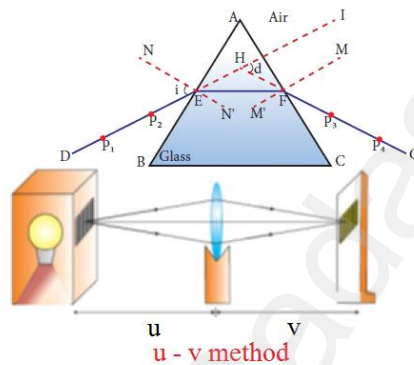

**Observation:**

Focal length of the convex lens (By distance object method) is (f) = .....20.....cm

2f = ...40....cm

S.No.	Size of the Image	Position of the object	Distance between the object and the lens (u) cm	Distance between the screen and the Lens (v) cm	Focal length of convex lens $f = \frac{uv}{u + v}$ cm
1.	Diminished	$u > 2f$	45	36	20
2.			50	33	19.8
3.	Same size	$u = 2f$	40	40	20
4.	Magnified	$u < 2f$	30	60	20
5.			35	46	19.8

**Result:**

The focal length of the given convex lens

1. By the distance object method  $f = \dots 20 \dots \text{cm}$

2. By the 'uv' method  $f = \dots 20 \dots \text{cm}$

### 3. DETERMINATION OF RESISTIVITY

#### Objective:

To determine the resistivity of the material of the given coil of wire.

#### Equipment required:

A coil of wire, screw gauge, a metre scale, battery, key, ammeter, voltmeter, rheostat and connecting Wires.

#### Formula:

The resistivity of the material of the coil of wire is

$$\rho = \left(\frac{A}{L}\right)R \text{ (in ohm metre)}$$

Where A is the area of cross section of the wire (m<sup>2</sup>)

L is the length of the coil of wire (m)

R is the resistance of the coil of wire (ohm)

#### Circuit Diagram:

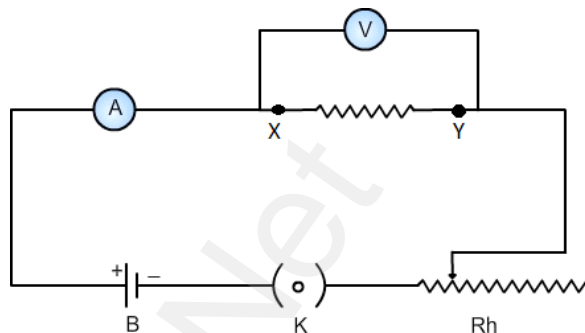

#### Procedure:

Connect the battery, ammeter, given wire, rheostat and key in series, as shown in the circuit diagram.

Connect the voltmeter in parallel to the unknown resistor.

- Close the key and hence the circuit is closed.
- Adjust the rheostat such that the ammeter reads a current of 0.5 ampere.
- Note down the potential difference across the resistor as shown by the voltmeter.
- Adjust the rheostat and change the current in steps of 0.5A (that is 0.5A, 1.0A, 1.5A, etc.).
- For each current, note down the corresponding potential difference as shown by the voltmeter.
- Tabulate the observations.
- Measure the diameter of the wire using a screw gauge.
- Measure the length of the coil using metre scale.

#### Observations:

##### (i) To find the resistance:

S.No.	Ammeter reading-I (Ampere)	Voltmeter reading-V (Volt)	Resistance = V/I (Ohm)
1.	0.5	1.5	3
2.	1.0	3.0	3
3.	1.5	4.5	3
Mean			3

##### (ii) To find the diameter of the wire using screw gauge:

S.No.	Pitch Scale Reading - PSR (mm)	Head scale Coincidence - HSC	Head scale reading- HSR = HSC x LC (mm)	Total reading = PSR + HSR (mm)
1.	1	43	0.43	1.43
2.	1	41	0.41	1.41
3.	1	42	0.42	1.42
Mean Diameter				1.42

#### Calculations:

Radius of the wire,  $r = \text{diameter}/2 = 0.71 \times 10^{-3} \text{ m}$

Area of cross section of the wire,  $A = \pi r^2 = 1.58 \times 10^{-6} \text{ m}^2$

Length of the wire  $L = 1 \text{ m}$ .

Resistivity of the material of the wire =  $\rho = \left(\frac{A}{L}\right)R = 4.74 \times 10^{-6} \Omega \text{ m}$

**Result:** The resistivity of the material of the wire =  $4.74 \times 10^{-6} \Omega \text{ m}$

Formula & Circuit – 1 Mark  
 Procedure – 1 Mark  
 Table – 2 Marks  
 Result – 1 Mark

## II. CHEMISTRY

### 1. IDENTIFY THE DISSOLUTION OF THE GIVEN SALT WHETHER IT IS EXOTHERMIC OR ENDOTHERMIC.

**Aim:**

To test the dissolution of given salt is exothermic or endothermic

**Principle:**

If the reaction or process liberates the heat, then it is called exothermic.

If the reaction or process absorbs the heat, then it is called endothermic

**Apparatus required:** Two beakers, Thermometer, stirrer, weighed amount of two samples.

Aim – 1 Mark

Procedure – 1 Mark

Observation – 1 Mark

Result – 2 Marks

**Procedure:**

Take 50ml of water in two beakers and label them as A and B. Note the temperature of the water from beaker A and B. Then, add 5g of sample A into the beaker A and stir well until it dissolve completely.

Record final temperature of the solution. Now, repeat the same for the sample B

Record the observation.

**Observation :**

S.No.	Sample	Temperature before addition of sample (°C)	Temperature after addition of sample (°C)	Inference ( Temperature increase or decrease)
1.	A	30	37	Increase
2.	B	30	25	Decrease

**Result:**

From the inferences made

The dissolution of sample A is Exothermic

The dissolution of sample B is Endothermic)

**Note:**

Sodium hydroxide, ammonium nitrate, glucose, calcium oxide etc. may be given as the sample.

### 2. TESTING THE SOLUBILITY OF THE SALT

**Aim:**

To test the solubility of the given salt based on the saturation and un saturation of the solution at a given temperature.

**Principle:**

A solution in which no more solute can be dissolved in the solvent at a given temperature is called saturated solution. If the solvent can dissolve more solute than what is present, the solution is called unsaturated solution.

**Materials Required:**

A 250 ml beaker, a Stirrer, sufficient quantity of distilled water, 100 ml measuring jar, table salt in three packets weighing as 25g, 11g, and 1g.

**Procedure:**

In a 250ml beaker, pour 100 ml water using measuring jar. To this water add table salt (25 g) from first packet. stir the content very well. Add the next packet containing 11 g salt followed by constant stirring .

Now add the third packet containing 1 g salt . Record your observations.

**Observation**

S.No.	Amount of salt added	Observation (Salt dissolved or undissolved)	Inference (Unsaturated / Saturated / Super saturated )
1.	25	dissolved	Unsaturated
2.	36(25+11)	Dissolved	Saturated
3.	37(25+11+1)	Undissolved	Super Saturated

**Result:** From the above observation, it is inferred that the amount of salt required for saturation is 36 g

Aim – 1 Mark

Procedure – 1 Mark

Observation – 2 Marks

Result – 1 Mark

### 3. TESTING THE WATER OF HYDRATION OF SALT

**Aim:**

To check whether the given sample of salt possesses 'Water of Hydration' or not. To verify the presence of water molecules in the given hydrated salt .

**Principle:**

Water of crystallization or water of hydration is the phenomenon shown by certain salts in which water molecules are present inside the crystals are responsible for their colour and geometry. e.g. Crystalline copper sulphate  $CuSO_4 \cdot 5H_2O$

**Materials Required:** A pinch of crystalline copper sulphate in a test tube, tongs, spirit lamp.

**Procedure:**

A pinch of crystalline copper sulphate taken in a test tube and heated for sometime. Water droplets are seen on the inner walls of the test tube. This shows that the given salt contains water of crystallization. If the above observation is not noticed for the given salt, the water of hydration is absent.



Aim – 1 Mark  
 Materials required – 1 Mark  
 Procedure – 2 Marks  
 Result – 1 Mark

**Result:**

In the given sample of salt, Water of crystallization / hydration is

- A) Present
- B) Absent

### 4. TEST THE GIVEN SAMPLE FOR THE PRESENCE OF ACID OR BASE

**Aim:**

To identify the presence of an acid or a base in a given sample.

**Materials Required:**

Test tubes, test tube stand, glass rod, phenolphthalein, methyl orange, sodium carbonate salt and the given sample.

**Principle:**

**In acid medium,**

- (a) Phenolphthalein is colourless
- (b) Methyl orange is pink in colour
- (c) Sodium carbonate gives brisk effervescence.

**In Base medium,**

- (a) Phenolphthalein is pink in colour
- (b) Methyl orange is yellow in colour
- (c) Sodium carbonate does not give brisk effervescence.

Aim – 1 Mark  
 Materials required – 1 Mark  
 Procedure & Observation – 2 Marks  
 Result – 1 Mark

S.No.	Experiment	Observation (Colour change)	Inference (Acid / Base)
1.	Take 5ml of the test solution in a test tube and add a few drops of Phenolphthalein in it.	a) No change in colour. b) Solution Turns pink in colour	a) Presence of acid b) Presence of base
2.	Take 5ml of the test solution in a test tube and add a few drops of Methyl orange in it.	a) Solution Turns pink in colour b) Solution Turns yellow in colour	a) Presence of acid b) Presence of base
3.	Take 5ml of the test solution in a test tube and add a pinch of sodium carbonate salt.	a) Brisk effervescence occurs. b) No brisk effervescence.	a) Presence of acid b) Presence of base

**Result:** The given test solution contains \_\_\_\_\_ (acid / base).

### III. BIO-BOTANY

EX. NO. : 1

#### PHOTOSYNTHESIS - TEST TUBE AND FUNNEL EXPERIMENT

**Aim:** To prove that oxygen is evolved during photosynthesis. (1 MARK)

**Materials required:** Test tube, funnel, beaker, pond water and Hydrilla plant. (1 MARK)

- Procedure:**
1. Take a few twigs of Hydrilla plant in a beaker containing pond water.
  2. Place an inverted funnel over the plant.
  3. Invert a test tube filled with water over the stem of the funnel.
  4. Keep the apparatus in the sunlight for few hours. (1 MARK)

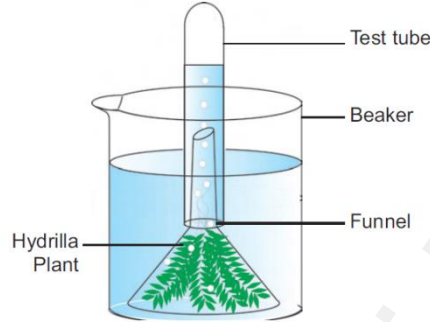

**Observation:** After one hour, it is noted that water gets displaced down from the test tube. (1 MARK)

**Inference :** During photosynthesis, oxygen is evolved as a by-product. Gas bubbles liberated from the Hydrilla plant reach the top of the test tube and it displaces the water downwards. Take the test tube and keep the burning stick near the mouth of the test tube. Increased flame will appear. Hence, it is proved that oxygen is evolved during photosynthesis. (1 MARK)

#### EX. NO. : 2 PARTS OF A FLOWER.

(Dissection 1 ½ marks, Display 1 ½ Marks, Diagram + Parts 1 + 1 = 2 Marks)

**Aim:** To dissect and display the parts of the given flower and observe the Calyx, Corolla, Androecium and Gynoecium. Draw labelled sketches.

**Materials Required:** Flower, needle and paper

**Procedure:** With the help of the needle dissect the different whorls of the flower.

**Floral Parts:**

##### A. Accessory organ

1. Calyx
2. Corolla

##### B. Reproductive organ

3. Androecium - Male part of the flower
4. Gynoecium - Female part of the flower

**Observation:**

Draw and label the parts of the flower.

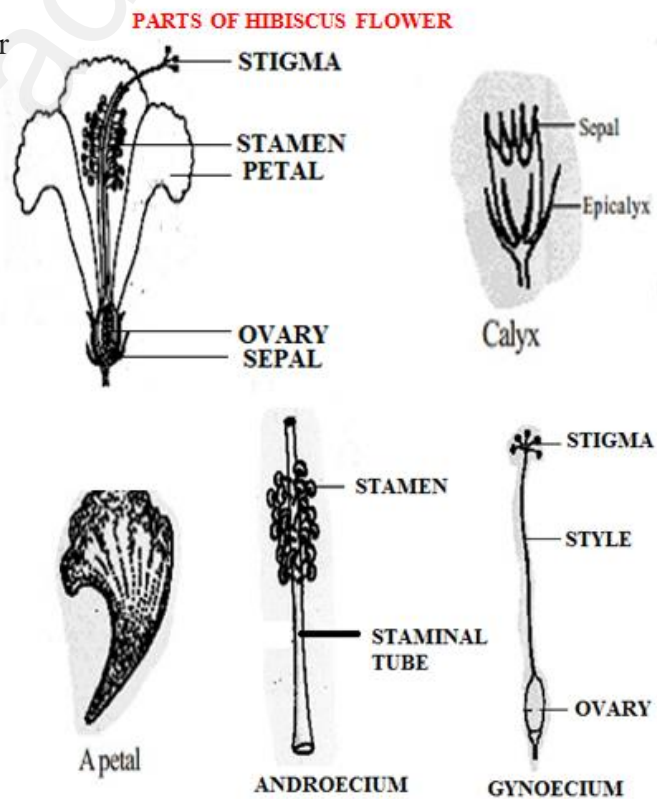

**EX. NO. : 3 STUDY OF LAW OF DOMINANCE**

**Aim:** To study the law of dominance by using model / picture / photograph. To find out the genotypic ratio and phenotypic ratio in pea plant using checker board. (1 MARK)

**Procedure:** Depict parental generation and the gametes using colour chalk pieces. (2 MARKS)

**Law of Dominance :** When two homozygous individuals with one or more sets of contrasting characters are crossed, the characters that appear in the F<sub>1</sub> hybrid are dominant and those that do not appear in F<sub>1</sub> are recessive characters.

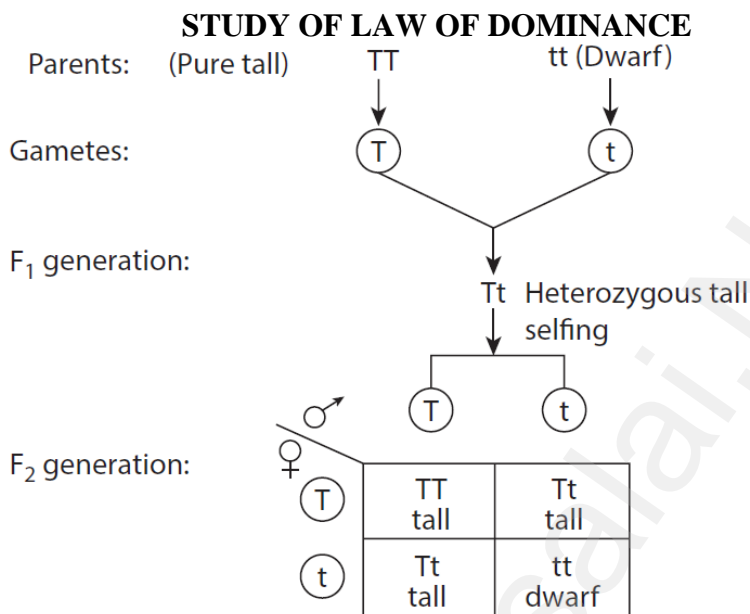

**Result: ( 2 Marks )**

**Phenotypic ratio 3:1**

**Genotypic ratio 1:2:1**

Inheritance of only one pair of contrasting character is called monohybrid cross. A cross between two forms of a single trait like a cross between tall and dwarf pea plant.

**EX. NO. : 4 MICRO SLIDE – T.S OF DICOT STEM**

**Aim:** To observe T.S of Dicot Stem from permanent slides.

**Identification:** The given slide is identified as T.S of Dicot Stem. (1 MARK)

**Diagram :** (Diagram 1 Mark + Parts 1 mark = 2 Marks)

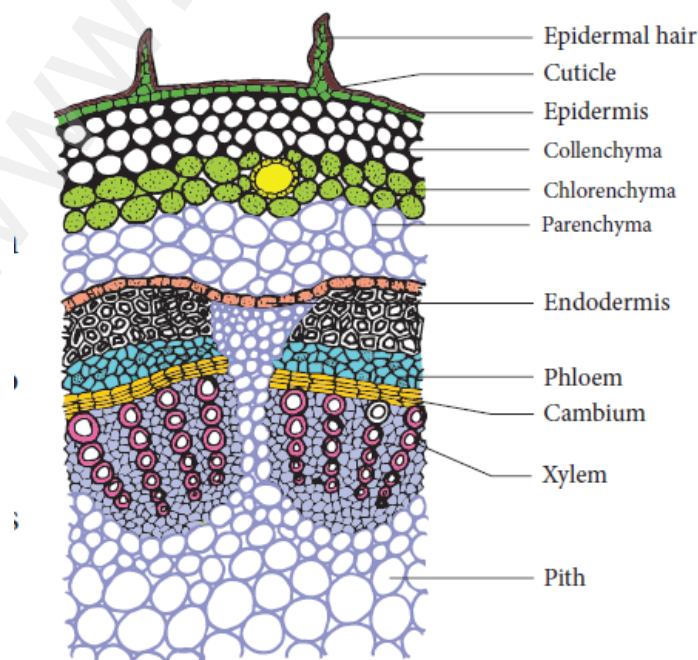



**Reason : (2 Marks)**

- i) Vascular bundles are arranged in a ring.
- ii) Conjoint, collateral, endarch and open vascular bundle.
- iii) Ground tissue differentiated into cortex, endodermis, pericycle and pith.
- iv) 3 to 6 layer of collenchymas tissues present in hypodermis.

**EX. NO. : 5                    MICRO SLIDE – T.S OF DICOT ROOT**

**Aim:** To observe T.S of Dicot Root from permanent slides.

**Identification:** The given slide is identified as T.S of Dicot Root (1 MARK)

**Diagram :** (Diagram 1 Mark + Parts 1 mark = 2 Marks)

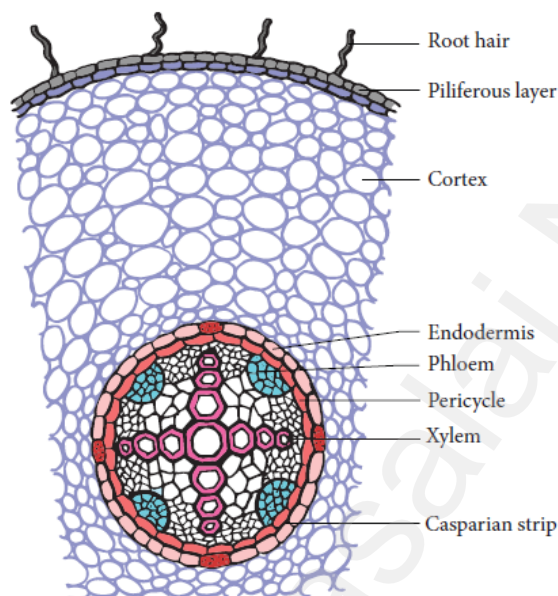

**Reason : (2 Marks)**

- i) Vascular bundle is radial.
- ii) 2 to 4 xylem are present.
- iii) Cambium is present.
- iv) Cortex is made up of parenchymatous cells.

**IV. BIO – ZOOLOGY**

**EX. NO. : 6                    MODEL – L.S. OF HUMAN HEART**

**Aim:** To observe and draw a labelled sketch of L.S of human heart and write the structure.

**Materials Required:** Model showing the L.S of human heart.

**Identification:** The given model is identified as L.S. of human heart. ( 1 Mark )

**Diagram :** (Diagram 1 Mark + Parts 1 Mark = 2 Marks)

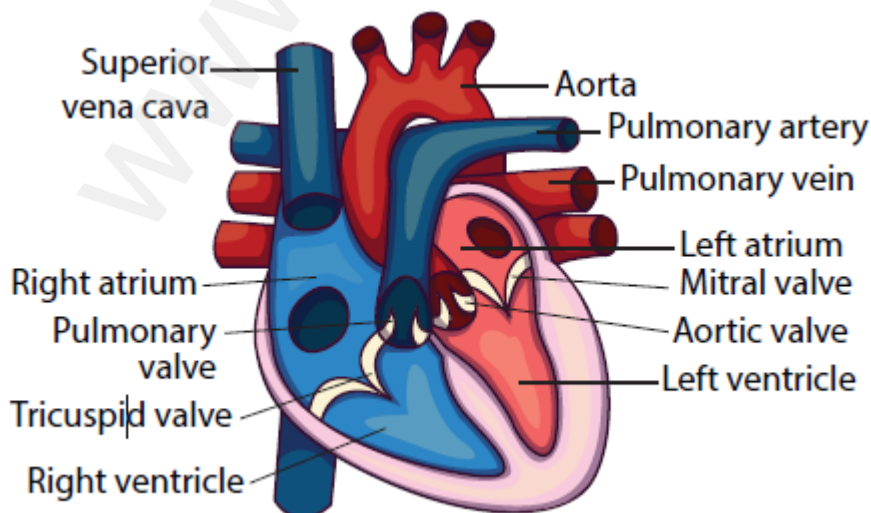

**Reasons : ( 2 Marks)**

1. The human heart has four chambers. It is made up of two auricles and two ventricles
2. The chambers are separated by interauricular and interventricular septum. It prevents the mixing of oxygenated and deoxygenated blood.
3. Tricuspid valve - It is located between the right auricle and the right ventricle
4. Bicuspid valve - It is located between the left auricle and the left ventricle
5. The heart is covered by a protective double walled membrane called pericardium
6. The heart pumps blood to all parts of the body.

**EX. NO. : 7**

**MODEL – L.S OF HUMAN BRAIN**

**Aim:** To observe and draw a labelled sketch of L.S of human brain and indicate the different regions of the brain.

**Materials Required :** Model showing the L.S of human brain.

**Identification:** The given model is identified as L.S. of human brain. (1 Mark)

**Diagram :** (Diagram 1 Mark + Parts 1 Mark = 2 Marks)

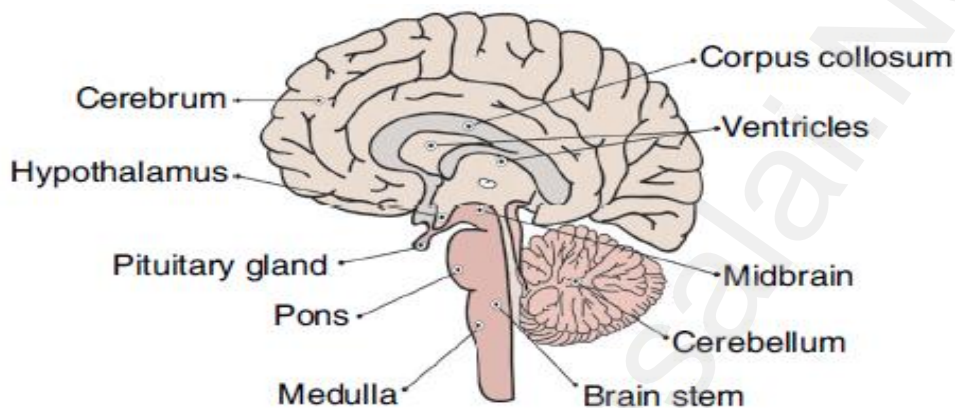

**Reasons : ( 2 Marks )**

1. The brain is enclosed in the cranial cavity
2. It is the controlling centre of all the body activities.
3. It is covered by three connective tissue membrane or meninges: Duramater Arachnoid membrane and Piamater
4. The human brain is divided into three parts namely forebrain, midbrain and hindbrain

**EX. NO. : 8**

**MICRO SLIDE – RED BLOOD CELLS**

**Aim:** Identification of blood cells (Red blood cells ). To draw a neat labelled diagram and write a note on the blood cells identified.

**Materials Required :** Permanent prepared slides of blood cells.

**Identification:** The given slide is identified as **Red blood cells.** ( 1 Mark )

**Diagram :** (Diagram 1 Mark + Parts 1 Mark = 2 Marks)

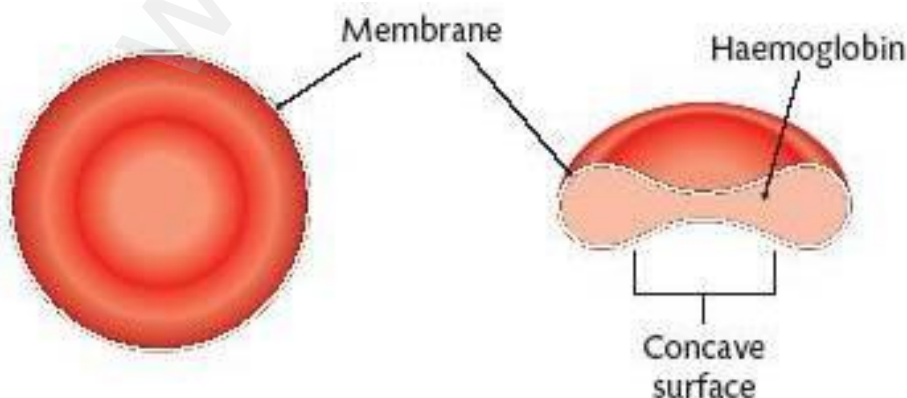

**Reasons : ( 2 Marks )**

1. They are biconcave and disc shaped.
2. They are also known as erythrocytes
3. Mature mammalian RBC's do not have nucleus.
4. Haemoglobin is a respiratory pigment which gives red colour.
5. It transports oxygen from lungs to tissues and carbon- dioxide from tissues to lungs

**EX. NO. : 9**

**MICRO SLIDE – WHITE BLOOD CELLS**

**Aim:** Identification of blood cells (White blood cells). To draw a neat labelled diagram and write a note on the blood cells identified.

**Materials Required :** Permanent prepared slides of blood cells.

**Identification:** The given slide is identified as **White blood cells.** ( 1 Mark )

**Diagram :** (Diagram 1 Mark + Parts 1 Mark = 2 Marks)

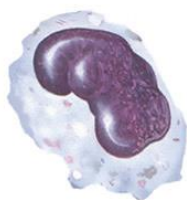

**Monocyte**



**Lymphocyte**



**Neutrophil**



**Eosinophil**

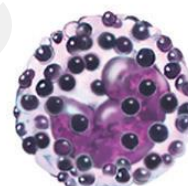

**Basophil**

**Reasons : ( 2 Marks)**

1. WBC's are colourless and they have nucleus.
2. They are also known as Leucocytes
3. They show amoeboid movements.
4. They fight against germs and other foreign bodies and thus protect the body from microbial infections and diseases.
5. There are five different types of WBC named as Neutrophils, Eosinophils, Basophils, Lymphocytes and Monocytes

**EX. NO. : 10**

**MODEL – THYROID GLAND**

**Aim:** To identify the endocrine gland, its location, hormone secreted and functions.

**Identification:** The flag labelled endocrine gland is identified as **Thyroid gland.** ( 1 Mark )

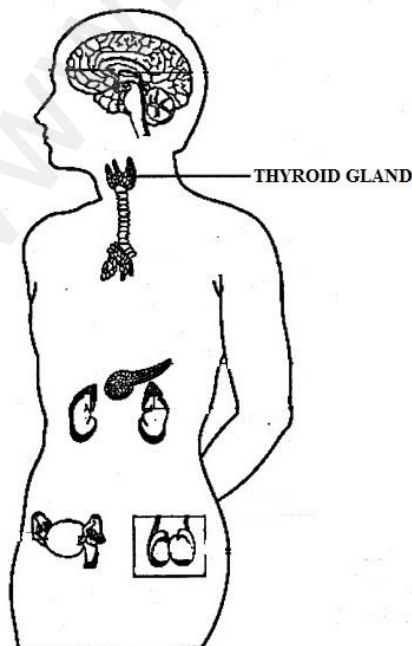

**Location: ( 1 Mark )**

Thyroid gland is a bilobed gland located in the neck region on either side of the trachea.

**Hormones secreted: ( 1 Mark )**

1. Triiodothyronine (T3) and
2. Thyroxine (T4)

**Functions of Hormones: ( 2 Marks )**

1. Thyroid hormones increases the basal metabolic rate (BMR).
2. It increases the body temperature.
3. It regulates metabolism.
4. It is required for normal growth and development
5. It is also known as personality hormone.
6. Deficiency of thyroxine results in simple goiter, myxoedema (in adults) and cretinism (in children).
7. Excess secretion causes Grave's diseases.

**EX. NO. : 11**

**MODEL – PANCREAS (ISLETS OF LANGERHANS)**

**Aim:** To identify the endocrine gland, its location, hormone secreted and functions.

**Identification: ( 1 Mark )**

The flag labelled endocrine gland is identified as Islets of Langerhans in the Pancreas.

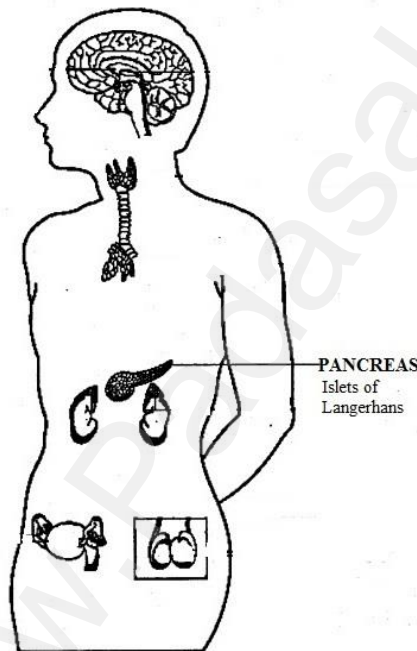

**Location: ( 1 Mark )**

Islets of Langerhans are seen embedded in the pancreas which is located in the abdominal region.

**Hormones secreted: ( 1 Mark )**

1.  $\alpha$  cells secrete glucagon
2.  $\beta$  cells secrete insulin

**Functions of Hormones: ( 2 Marks )**

1. Insulin converts glucose into glycogen and stores it in liver and muscles.
2. Glucagon converts glycogen into glucose.
3. Insulin and glucagon maintain the blood sugar level (80 – 120 mg/dl) by their antagonistic function.
4. Decrease in insulin secretion causes diabetes mellitus.

Prepared by  
**M.G.RAYMOND, M.Sc., B.Ed.,**  
**ST.PAUL'S MAT. HR. SEC. SCHOOL,BLOCK – 4, NEYVELI -607801.**  
**9629705161 / 9442980841 [raymondmg2001@gmail.com](mailto:raymondmg2001@gmail.com)**