



**EDUCATION DEPARTMENT
VILLUPURAM DISTRICT**

MATHEMATICS

10



Material for Students

2024-25

**Achieved State Level 10th Place in
SSLC Public Examination - March 2024**

BEST WISHES

வா. அறிவுழகன், M.A., M.A., B.Ed., M.Phill.,
Chief Educational Officer, Villupuram District.

தன்னம்பிக்கை + விடாநாயற்சி + கடின உழைப்பு = வெற்றி

"The Struggle you're in Today will definitely develop the strength you need for Tomorrow.

A. SIVAMOORTHY, Government High School, Perumbakkam, Villupuram District.

Mobile: 9750827997

Kindly Send Me Your Key Answer to Our email id - Padasalai.net@gmail.com



ரெ. அறிவழகன், M.A., M.A., B.Ed., M.Phil.,
முதன்மைக் கல்வி அலுவலர்,
விழுப்புரம்.

MESSAGE TO TEACHERS

First and foremost I would like to express my hearty gratitude to all the maths handling teachers who took much effort so as to bring the SSLC public result in the **10th Place in State Level last year.**

I am very happy to here that more than 85% of the question were asked only from **our District Level Maths Material** and more over the question papers used for the preparatory through out the Academic Year 2023-24 were more helpful for the students to show their victory without any hindrance.

I need the same kind of co-operation cent percent from the teachers' side in this academic year too. In my point of view a dedicated and service minded teacher is always blessed by the God ever. Hence the teachers are asked to devote more time for the upliftment of poor rural pupils as education is the process of acquiring knowledge and skills.

Details of the Public Questions which took place in our Maths Material.

GOVT. QUESTION PAPER - MARCH 2024

Pub. Q.No.	Mat. P.No.	Mark	Pub. Q.No.	Mat. P.No.	Mark	Total Marks
1	58-1	1	15	14-1	2	8
2	58-11	1	16	67-1	2	8
3	59-5	1	17	20-1	2	8
4	59-10	1	18	27-2i	2	8
5	60-8	1	19	29-10	2	8
6	60-12	1	20	105-2	2	8
7	61-6	1	21	119-2	2	8
8	61-12	1	22	117-24	2	8
9	62-1	1	23	44-3	2	8
10	63-7	1	24	-	-	6
11	64-3	-	25	138-8	2	2
12	64-15	1	26	49-1	2	8
13	-	-	27	51-17	2	7
14	65-12	1	28	71-2	2	8
		12			26	8
			43 (a)	66-4	8	8
			43 (b)	6-9	8	8
			44 (a)	66-12	8	8
			44 (b)	11 - 6	8	8
		97				135

GOVT. QUESTION PAPER - JUNE 2024

Pub. Q.No.	Mat. P.No.	Mark	Pub. Q.No.	Mat. P.No.	Mark	Total Marks
1	58-10	1	15	14-4	2	8
2	58-8	1	16	-	-	6
3	59-6	1	17	-	-	6
4	60-6	1	18	27-1(ii)	2	8
5	60-17	1	19	85-13	2	8
6	61-9	1	20	104-6	2	8
7	61-11	1	21	113-3	2	8
8	62-3	1	22	118-27	2	8
9	62-10	1	23	128-6	2	8
10	63-2	1	24	139-1	2	8
11	63-10	1	25	47-3	2	8
12	64-3	1	26	50-7	2	3
13	65-9	1	27	51-16	2	8
14	65-2	1	28	21-9	2	3
		14			24	8
			43 (a)	7-12	8	8
			43 (b)	66-5	8	8
			44 (a)	12-8	8	8
			44 (b)	66 - 4	8	8
		87				125

Details of the Public Questions which took place in our Previous Year District Level Question Papers.

GOVT. QUESTION PAPER - MARCH 2024

Pub. Q.No.	Vil. Dt. Q.P.No.	Pub. Q.No.	Vil. Dt. Q.P.No.	Mark	Pub. Q.No.	Vil. Dt. Q.P.No.	Mark	
1		15	IR - 15	2	29	IR - 30	5	
2		16	Q ^{ly} - 16	2	30	IR - 29	5	
3		17	I Mid - 11	2	31			
4		18			32			
5	IR - 8	19		1	33	III R - 34	5	
6		20			34	III R - 36	5	
7		21			35			
8	III R - 7	22	IR - 24	2	36	H ^{ly} - 38	5	
9		23	H ^{ly} - 23	2	37	IR - 39	5	
10		24	IR - 26	2	38	III R - 40	5	
11		25			39	II Mid - 7	5	
12		26	IR - 27	2	40			
13		27			41	III R - 43	5	
14	IR - 13	28		1	42	II R - 32	5	
					43 (a)	H ^{ly} - 43	8	
					43 (b)			
					44 (a)	S.T4 - 4	8	
					44 (b)			
				3				
							14	66
							Total = 83 Marks	

GOVT. QUESTION PAPER - JUNE 2024

Pub. Q.No.	Vil. Dt. Q.P.No.	Pub. Q.No.	Vil. Dt. Q.P.No.	Mark	Pub. Q.No.	Vil. Dt. Q.P.No.	Mark	
1	I Mid - 3	15	H ^{ly} - 15	2	29	H ^{ly} - 29	5	
2	III R - 1	16			30	II R - 29	5	
3	I Mid - 5	17	S.T 3 - 4	2	31	H ^{ly} - 31	5	
4		18			32	II R - 33	5	
5	II Mid - 1	19	Q - 9	2	33	IR - 32	5	
6		20			34	S.T 7-12	5	
7	S.T4 - 2	21		1	35	IR - 36	5	
8		22			36			
9		23			37			
10		24			38			
11		25	II R - 26	2	39	II R - 40	5	
12		26	II R - 27	2	40			
13	II R - 14	27		1	41	S.T 6-16	5	
14	IR - 14	28	ST 2 - 4	2	42			
					43 (a)			
					43 (b)	H ^{ly} - 43	8	
					44 (a)	H ^{ly} - 44	8	
					44 (b)			
				7				
							12	61
							Total = 80 Marks	

4

GEOMETRY

1. Construct a triangle similar to a given triangle PQR with its sides equal to $\frac{3}{5}$ of the corresponding sides of the triangle PQR (scale factor $\frac{3}{5} < 1$)

Solution:

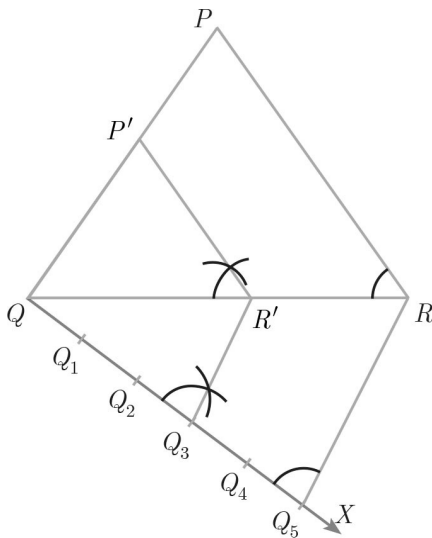

Rough diagram

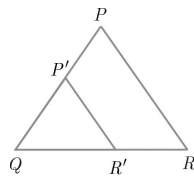

2. Construct a triangle similar to a given triangle PQR with its sides equal to $\frac{7}{4}$ of the corresponding sides of the triangle PQR (scale factor $\frac{7}{4} > 1$)

Solution:

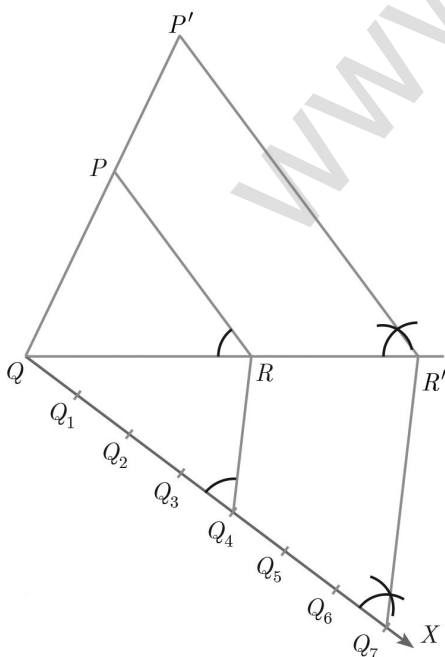

Rough diagram

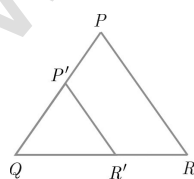

3. Construct a triangle similar to a given triangle PQR with its sides equal to $\frac{2}{3}$ of the corresponding sides of the triangle PQR (scale factor $\frac{2}{3} < 1$).

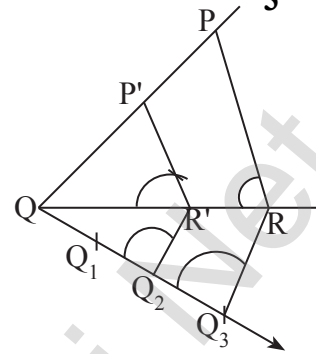

4. Construct a triangle similar to a given triangle LMN with its sides equal to $\frac{4}{5}$ of the corresponding sides of the triangle LMN (scale factor $\frac{4}{5} < 1$).

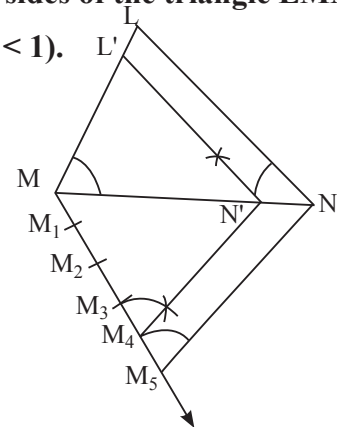

5. Construct a triangle similar to a given triangle ABC with its sides equal to $\frac{6}{5}$ of the corresponding sides of the triangle ABC (scale factor $\frac{6}{5} > 1$).

SEP-20

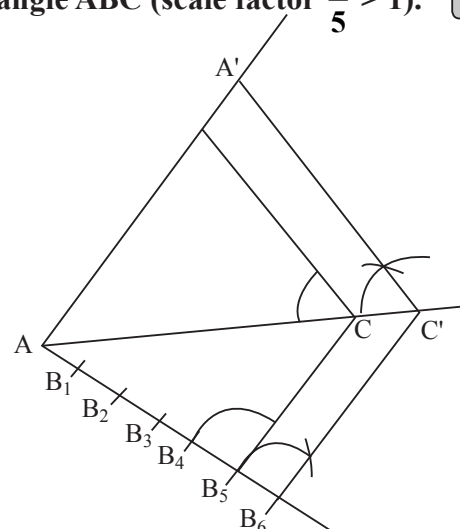

6. Construct a triangle similar to a given triangle PQR with its sides equal to $\frac{7}{3}$ of the corresponding sides of the triangle PQR (scale factor $\frac{7}{3} > 1$).

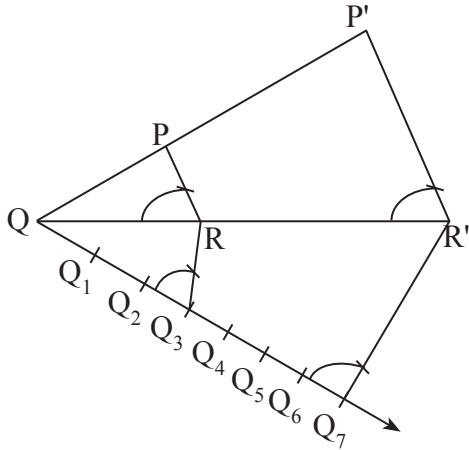

7. Draw a circle of radius 3 cm. Take a point P on this circle and draw a tangent at P.

Solution:

Given, radius $r = 3$ cm

Rough diagram

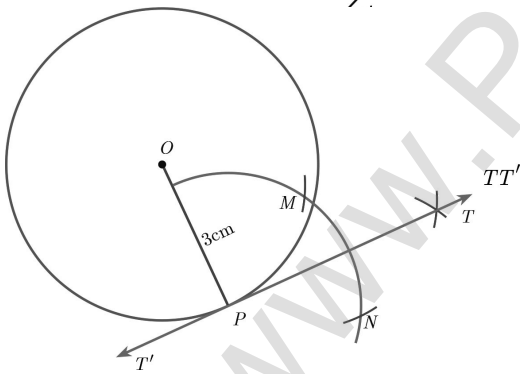
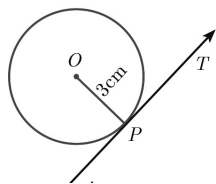

8. Draw a circle of radius 4 cm. At a point L on it draw a tangent to the circle using the alternate segment.

Solution:

Rough diagram

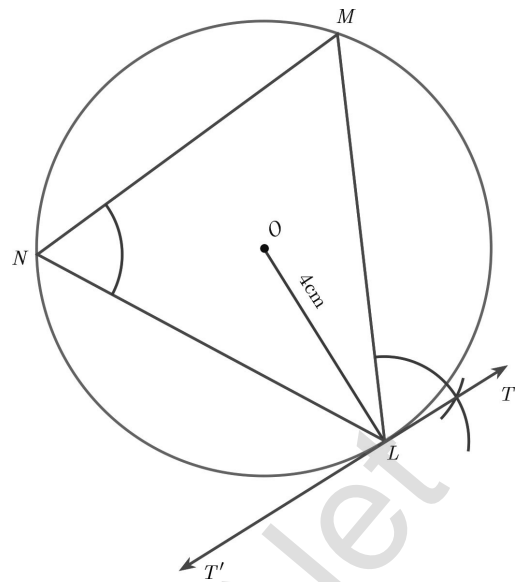
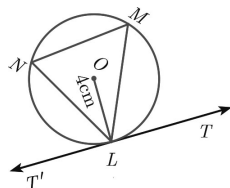

9. Draw a circle of diameter 6 cm from a point P, which is 8 cm away from its centre. Draw the two tangents PA and PB to the circle and measure their lengths.

Verification: In the right angle triangle OAP.

$$PA^2 - OA^2 = 64 - 9 = 55$$

$$PA = \sqrt{55} = 7.4 \text{ cm}$$

Solution:

Rough diagram

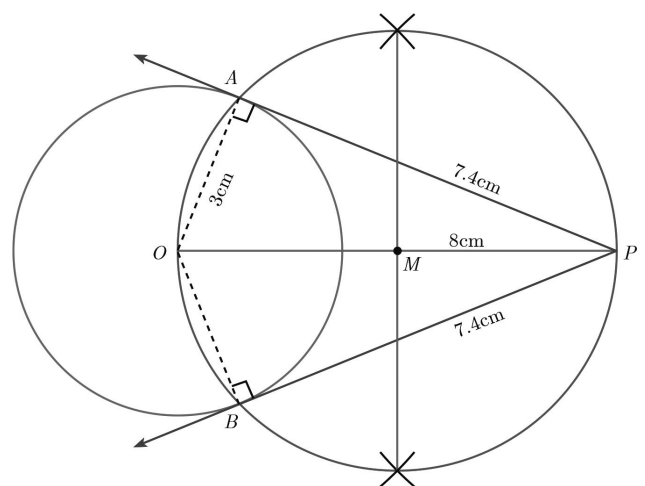
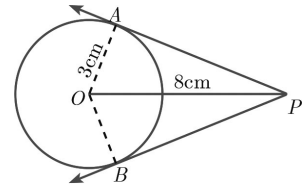

10. Draw a circle of radius 4.5 cm. Take a point on the circle. Draw the tangent at that point using the alternate segment theorem.

Solution:

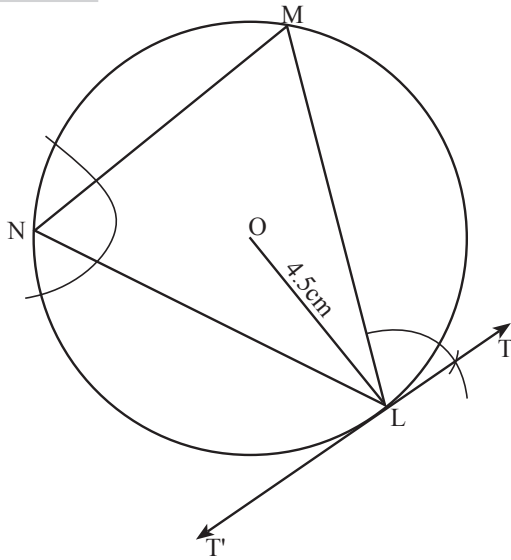

11. Draw a circle of radius 4.5 cm. Take a point on the circle. Draw the tangent at that point using the alternate segment theorem.

Solution:

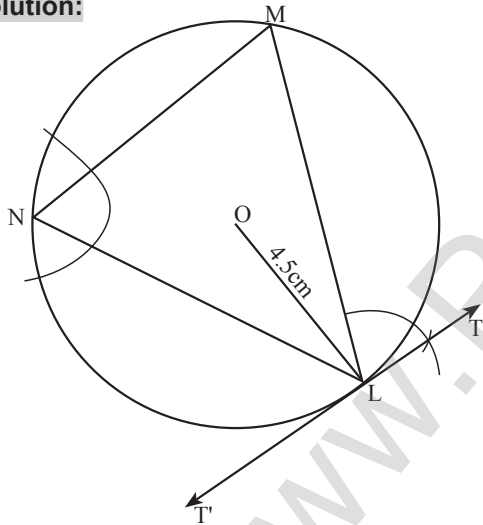

12. Draw the two tangents from a point which is 10 cm away from the centre of a circle of radius 5 cm. Also, measure the lengths of the tangents.

SEP-20

Solution:

Rough Diagram

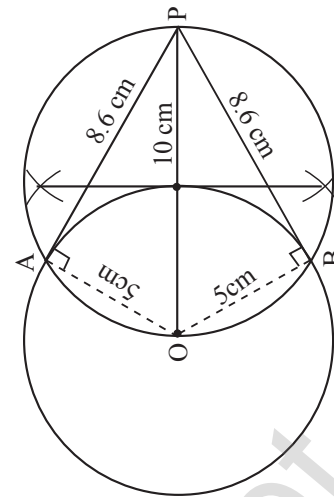
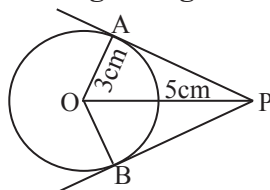

Proof:

In $\triangle OPA$

$$PA^2 = OP^2 - OA^2$$

$$= 10^2 - 5^2 = 100 - 25 = 75$$

$$PA = \sqrt{75} = 8.6 \text{ cm (approx)}$$

13. Take a point which is 11 cm away from the centre of a circle of radius 4 cm and draw the two tangents to the circle from that point.

Rough Diagram

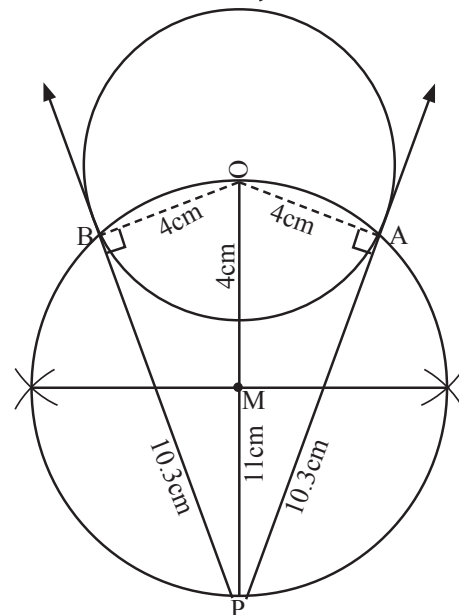
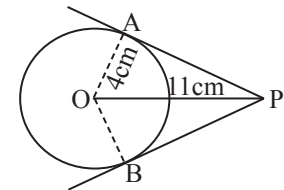

Verification:

$$\text{In } \triangle OPA \text{ } AP^2 = OP^2 - OA^2$$

$$= 11^2 - 4^2 = 121 - 16 = 105$$

$$AP = \sqrt{105} = 10.2 \text{ cm}$$

14. Draw the two tangents from a point which is 5 cm away from the centre of a circle of diameter 6 cm. Also, measure the lengths of the tangents.

SEP-21

Solution:

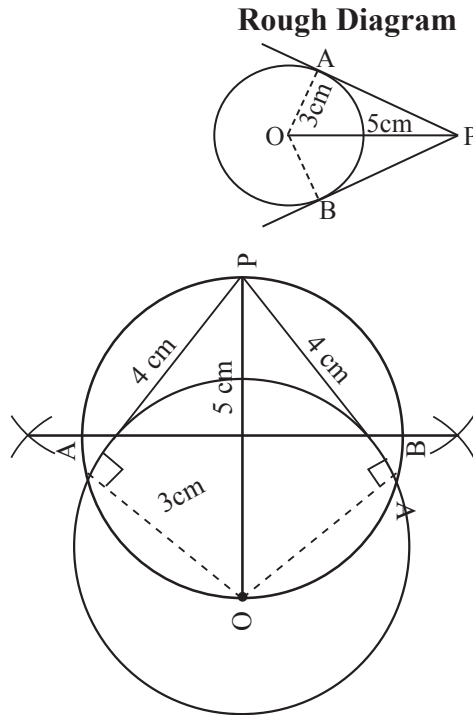
**Verification**

$$\begin{aligned} \text{In } \triangle OPA \quad AP^2 &= OP^2 - OA^2 \\ &= 5^2 - 3^2 = 25 - 9 = 16 \\ AP &= \sqrt{16} = 4 \text{ cm} \end{aligned}$$

15. Draw a tangent to the circle from the point P having radius 3.6 cm, and centre at O. Point P is at a distance 7.2 cm from the centre.

Solution:

Rough Diagram

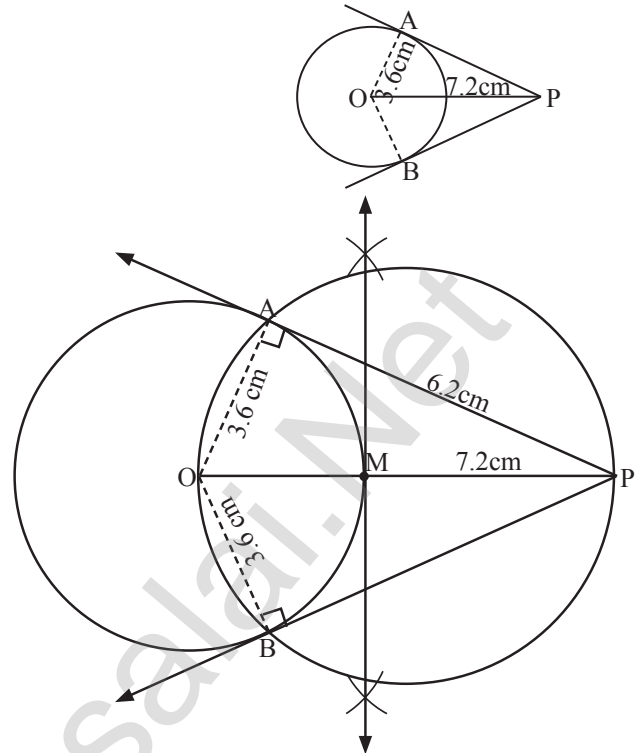
**Verification:**

$$\begin{aligned} \text{In } \triangle OPA, \quad PA^2 &= OP^2 - OA^2 \\ &= 7.2^2 - 3.6^2 \\ &= 51.84 - 12.96 \\ &= 38.88 \\ PA &= \sqrt{38.88} = 6.2 \text{ cm (approx)} \end{aligned}$$

GRAPH

1. Varshika drew 6 circles with different sizes. Draw a graph for the relationship between the diameter and circumference of each circle as shown in the table and use it to find the circumference of a circle when its diameter is 6 cm.

Diameter (x) cm	1	2	3	4	5
Circumference (y) cm	3.1	6.2	9.3	12.4	15.5

Solution:

1. **Table:**

Diameter(x) cm	1	2	3	4	5	6
Circumference (y) cm	3.1	6.2	9.3	12.4	15.5	18.6

2. **Variation:**

Direct Variation

3. **Equation:**

$$y = kx$$

$$k = \frac{y}{x} = \frac{3.1}{1} = 3.1$$

$$\therefore y = 3.1x$$

4. **Points:**

(1, 3.1) (2, 6.2) (3, 9.3), (4, 12.4),
(5, 15.5), (6, 18.6)

5. **Solution:**

From the graph, when diameter is 6 cm, its circumference is **18.6 cm**.

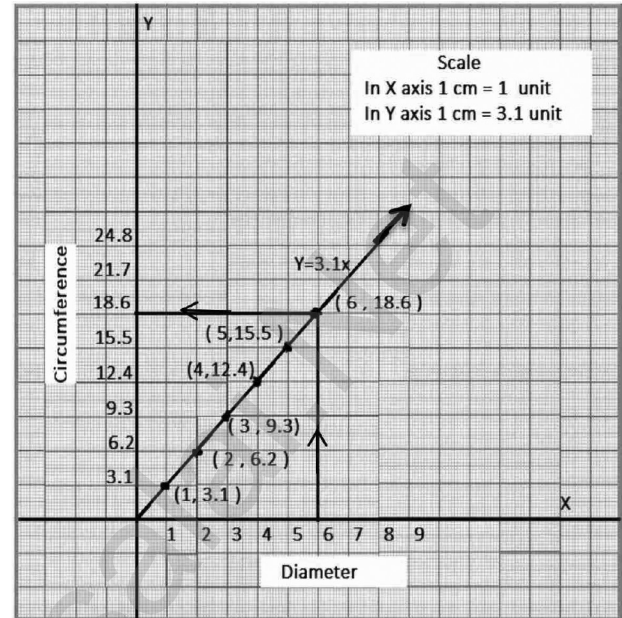

2. A bus is travelling at a uniform speed of 50 km/hr. Draw the distance-time graph and hence find
(i) the constant of variation (ii) how far will it travel in $1\frac{1}{2}$ hr
(iii) the time required to cover a distance of 300 km from the graph.

Solution: 1. **Table**

Time taken x (in minutes)	60	120	180	240	300	360
Distance y (in km)	50	100	150	200	250	300

2. **Variation:**

Direct Variation.

3. **Equation:**

$$y = kx$$

$$k = \frac{y}{x} = \frac{50}{60} = \frac{5}{6} \therefore y = \frac{5}{6}x$$

III. **Points:**

(60, 50), (120, 100), (180, 150), (240, 200),
(300, 250)

IV. **Solution:**

From the graph,

(i) Constant of variation $k = \frac{5}{6}$

(ii) The distance travelled in 90 mins = **75 km**

(iii) The time taken to cover 300 km = **360 minutes = 6 hours**.

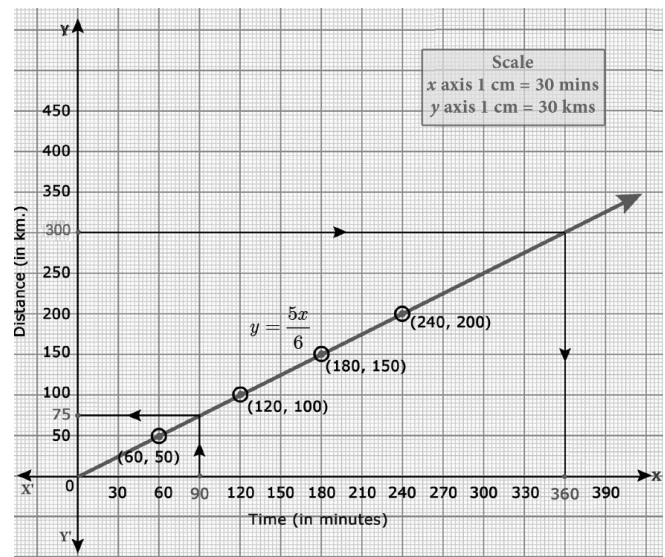

3. A company initially started with 40 workers to complete the work by 150 days. Later, it decided to fasten up the work increasing the number of workers as shown below.

Number of workers (x)	40	50	60	75
Number of days (y)	150	120	100	80

- (i) Graph the above data and identify the type of variation. (ii) From the graph, find the number of days required to complete the work if the company decides to opt for 120 workers? (iii) If the work has to be completed by 30 days, how many workers are required?

Solution: 1. Table

Number of workers (x)	40	50	60	75	100	120
Number of days (y)	150	120	100	80	60	50

2. **Variation:**

Indirect Variation.

3. **Equation:**

$$xy = k$$

$$xy = 40 \times 150 = 6000$$

$$xy = 6000$$

4. **Points:**

(30, 200), (40, 150) (50, 120) (60, 100),
(75, 80)

5. **Solution:**

From the graph,

(i) Type of variation = **Indirect variation**

(ii) The required number of days to complete

the work when the company decides to work with 120 workers = **50 days.**

(iii) If the work has to be completed by 200 days, the number of workers required = **30 workers**

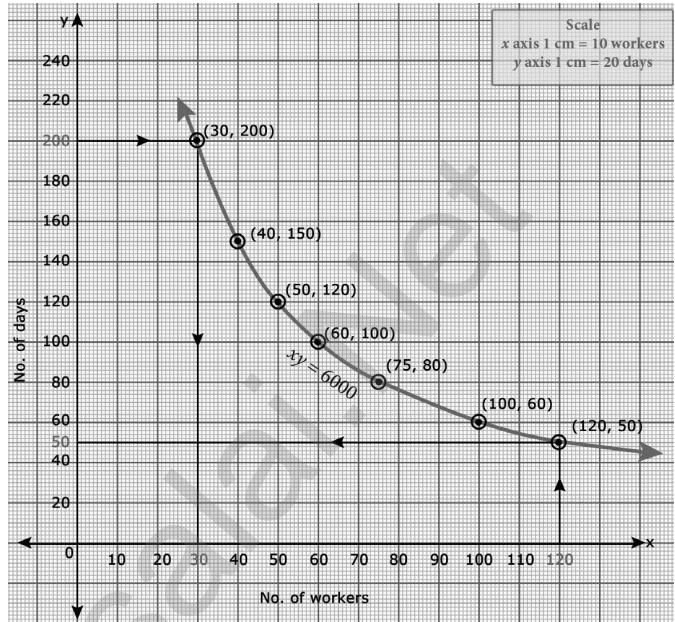

4. Nishanth is the winner in a Marathon race of 12 km distance. He ran at the uniform speed of 12 km/hr and reached the destination in 1 hour. He was followed by Aradhana, Ponmozhi, Jeyanth, Sathya and Swetha with their respective speed of 6 km/hr, 4 km/hr, 3 km/hr and 2 km/hr. And, they covered the distance in 2 hrs, 3 hrs, 4 hrs and 6 hours respectively. Draw the speed-time graph and use it to find the time taken to Kaushik with his speed of 2.4 km/hr.

Solution: 1. Table:

Speed x (km/hr)	12	6	4	3	2
Time y (hours)	1	2	3	4	6

2. **Variation:**

Indirect Variation

3. **Equation**

$$xy = k$$

$$xy = 12 \times 1 = 12$$

$$xy = 12$$

4. **Points:**

(12, 1), (6, 2), (4, 3), (3, 4), (2, 6)

5. **Solution:**

From the graph, The time taken by Kaushik to go at a speed of 2.4 km/hr = **5 hours.**

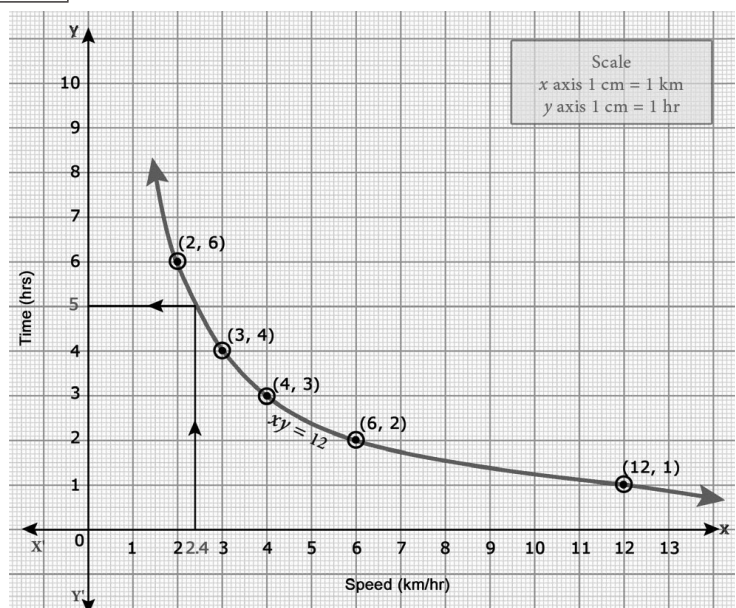

5. A garment shop announces a flat 50% discount on every purchase of items for their customers. Draw the graph for the relation between the Marked Price and the Discount. Hence find
- the marked price when a customer gets a discount of ₹ 3250 (from graph)
 - the discount when the marked price is ₹ 2500

Solution: 1. Table (Given)

Marked Price ₹ (x)	1000	2000	3000	4000	5000	6000	7000
Discounted Price ₹ (y)	500	1000	1500	2000	2500	3000	3500

2. Variation:

Direct variation.

3. Equation:

$$y = kx$$

$$k = \frac{y}{x} = \frac{500}{1000} = \frac{1}{2}$$

$$y = \frac{1}{2}x$$

4. Points:

(1000, 500), (2000, 1000), (3000, 1500), (4000, 2000), (5000, 2500), (6000, 3000), (7000, 3500)

5. Solution:

From the graph,

- If the customer gets a discount of ₹ 3250, then X' the Marked price = ₹ 6500
- If the marked price is ₹ 2500, then the discount = ₹ 1250

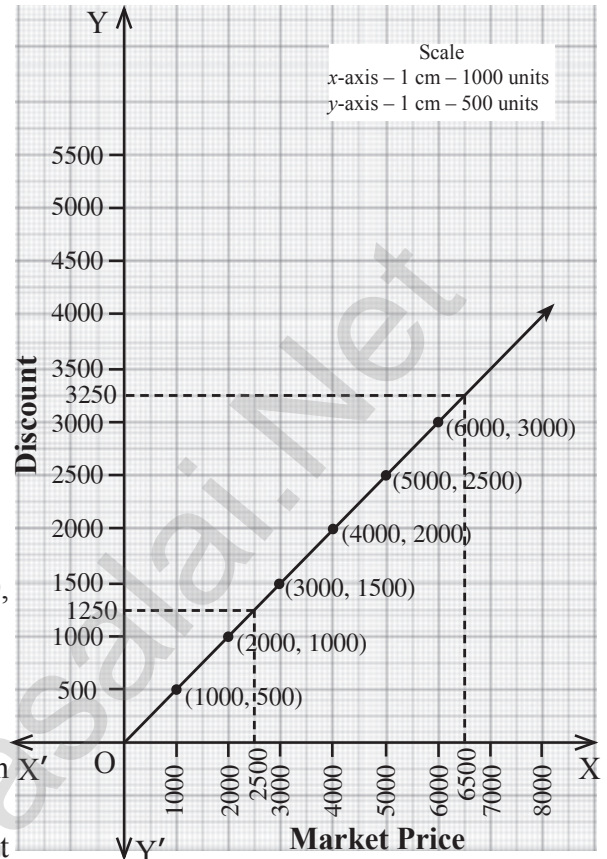

6. Draw the graph of $xy = 24$, $x, y > 0$. Using the graph find,

- y when $x = 3$ and (ii) x when $y = 6$.

Solution: 1. Table:

x	12	8	6	4	3	2
y	2	3	4	6	8	12

2. Variation:

Indirect variation.

3. Equation:

$$xy = k$$

$$xy = 12 \times 2 = 24$$

$$xy = 24$$

4. Points:

(12, 2), (8, 3), (6, 4), (4, 6), (3, 8), (2, 12)

5. Solution:

From the graph,

- If $x = 3$ then $y = 8$
- If $y = 6$ then, $x = 4$

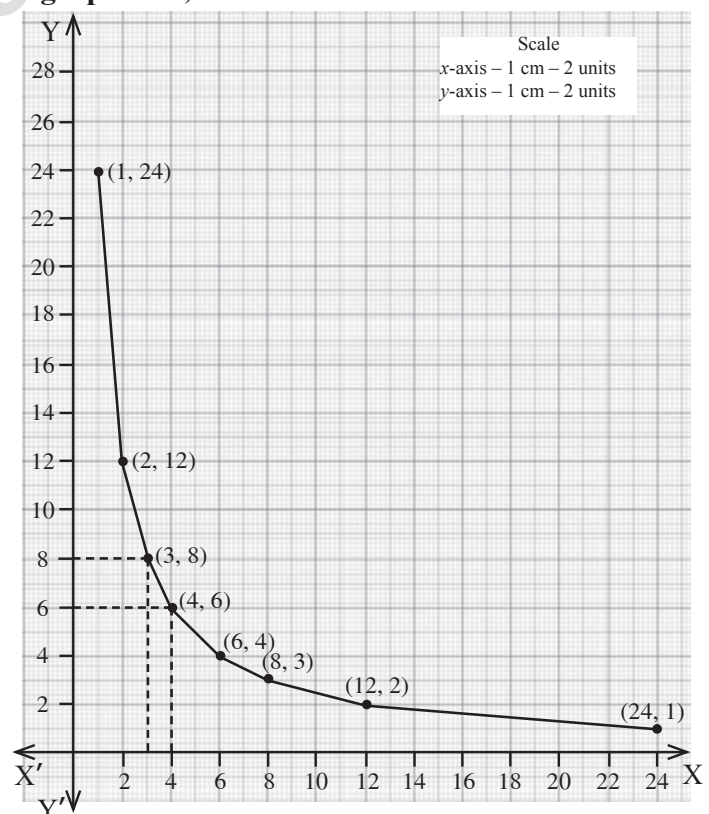

7. Graph the following linear function $y = \frac{1}{2}x$. Identify the constant of variation and verify it with the graph. Also (i) find y when $x = 9$ (ii) find x when $y = 7.5$.

Solution: 1. Table:

x	2	4	6	8	10	12	14	16
y	1	2	3	4	5	6	7	8

2. **Variation:**

Direct Variation

3. **Equation:**

$$y = kx$$

$$k = \frac{y}{x} = \frac{1}{2}$$

$$y = \frac{1}{2}x$$

4. **Points:**

(2, 1), (4, 2), (6, 3), (8, 4), (10, 5), (12, 6), (14, 7), (16, 8)

5. **Solution:**

From the graph,

(i) If $x = 9$ then $y = 4.5$

(ii) If $y = 7.5$ then $x = 15$

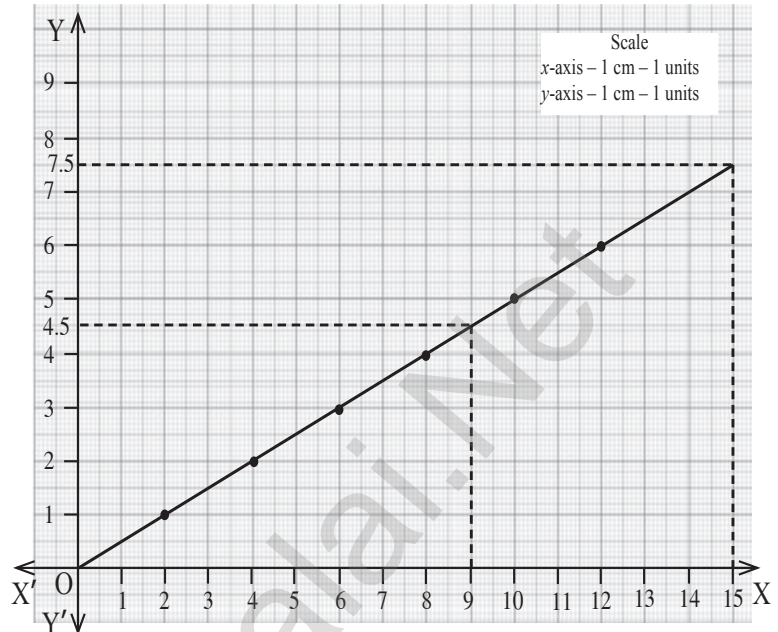

8. The following table shows the data about the number of pipes and the time taken to fill the same tank.

No. of pipes (x)	2	3	6	9
Time Taken (in min) (y)	45	30	15	10

Draw the graph for the above data and hence

- (i) find the time taken to fill the tank when five pipes are used
(ii) find the number of pipes when the time is 9 minutes.

Solution:

1. **Table:**

No. of pipes (x)	2	3	5	6	9	10
Time Taken (y) (mins)	45	30	18	15	10	9

2. **Variation:**

Indirect variation

3. **Equation:**

$$xy = k$$

$$xy = 2 \times 45 = 90$$

$$xy = 90$$

3. **Points:**

(2, 45), (3, 30), (5, 18), (6, 15), (9, 10), (10, 9)

4. **Solution:**

From the graph,

(i) Time taken to fill the tank if using 5 pipes = **18 minutes**

(ii) Number of pipes used if the tank fills up in 9 minutes = **10 pipes**

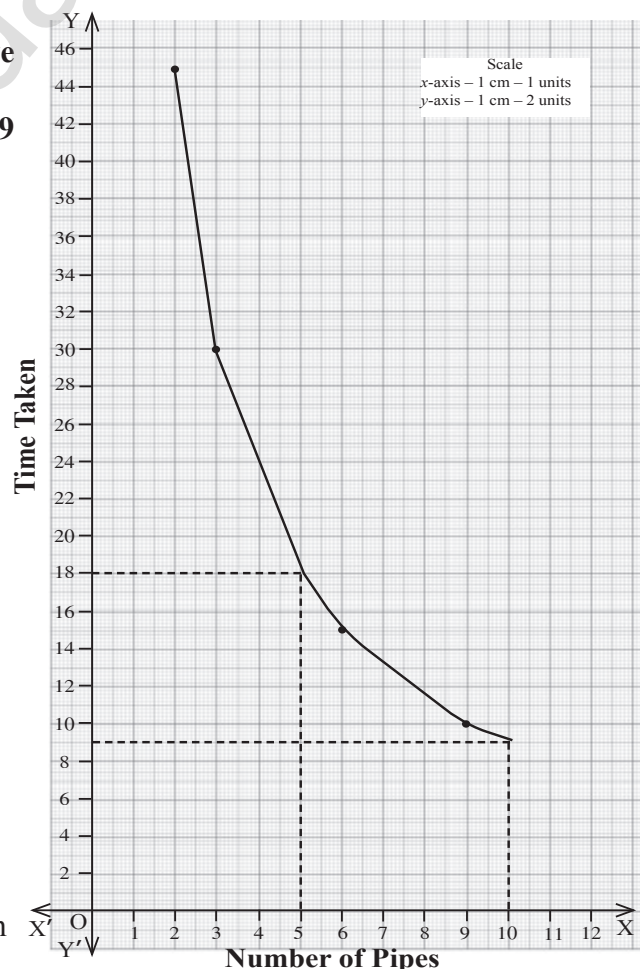

9. A school announces that for a certain competitions, the cash price will be distributed for all the participants equally as show below

No. of participants (x)	2	4	6	8	10
Amount for each participant in ₹ (y)	180	90	60	45	36

(i) Find the constant of variation.

(ii) Graph the above data and hence, find how much will each participant get if the number of participants are 12.

Solution: 1. Table:

No. of participants (x)	2	4	6	8	10	12
Amount for each participant in ₹ (y)	180	90	60	45	36	30

2. Variation:

Indirect variation.

3. Equation:

$$xy = k$$

$$xy = 2 \times 180 = 360$$

$$xy = 360$$

4. Points:

(2, 180), (4, 90), (6, 60), (8, 45), (10, 36), (12, 30)

5. Solution:

(i) Constant of Variation: $k = 360$

(ii) Cash Price each participant will get if 12 participants participate = **Rs. 30**

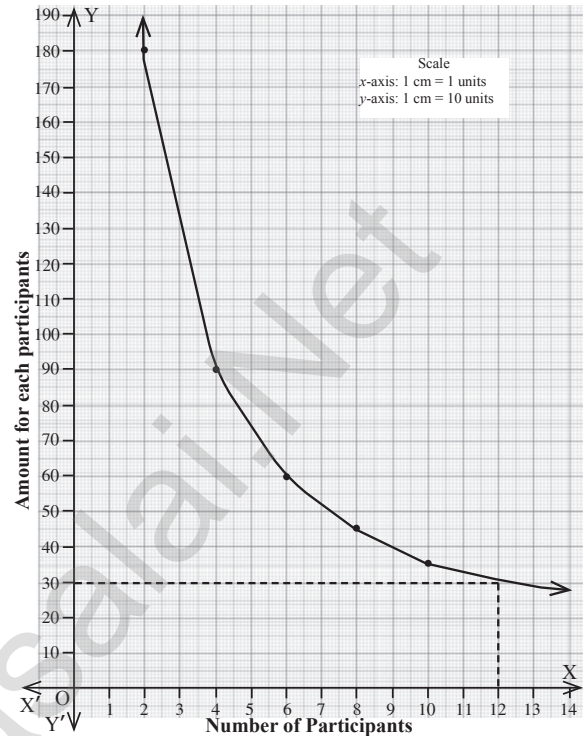

10. A two wheeler parking zone near bus stand charges as below.

Time (in hours) (x)	4	8	12	24
Amount ₹ (y)	60	120	180	360

Check if the amount charged are in direct variation or in inverse variation to the parking time. Graph the data. Also (i) find the amount to be paid when parking time is 6 hr; (ii) find the parking duration when the amount paid is ₹150.

Solution: I. Table:

Time (in hours) (x)	4	6	8	10	12	24
Amount in ₹ (y)	60	90	120	150	180	360

2. Variation:

Direct variation.

3. Equation:

$$y = kx,$$

$$k = \frac{y}{x} = \frac{60}{4} = 15$$

$$y = 15x$$

4. Points:

(4, 60), (6, 90), (8, 120), (10, 150), (12, 180), (24, 320)

5. Solution:

From the graph,

(i) If the parking time is 6 hours, then the parking charge = ₹ 90.

(ii) If the amount ₹ 150 is paid, then the Parking time = **10 hours**.

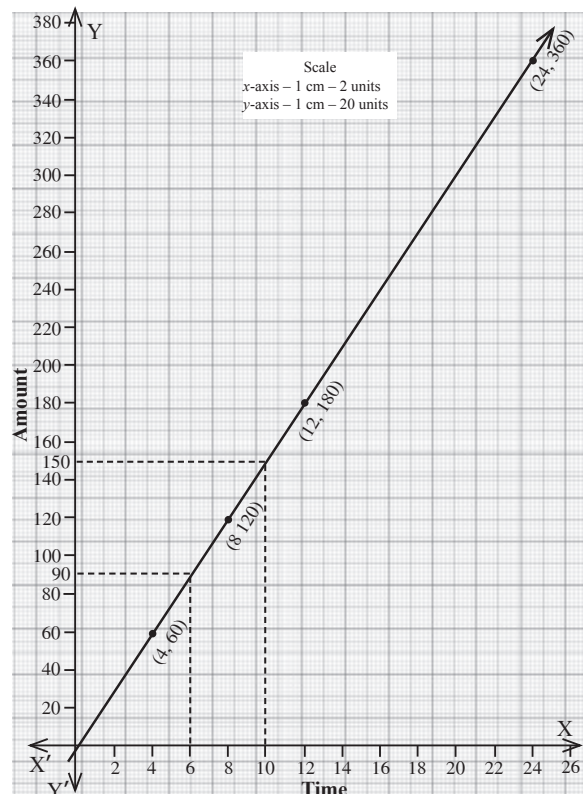

1. Relations and Functions

2 Marks

1. If $A \times B = \{(3, 2), (3, 4), (5, 2), (5, 4)\}$ then find A and B. SEP-20

Solution:

$A \times B = \{(3, 2), (3, 4), (5, 2), (5, 4)\}$ then

$A = \{\text{Set of all first coordinates of elements of } A \times B\} \therefore A = \{3, 5\}$

$B = \{\text{Set of all second coordinates of elements of } A \times B\} \therefore B = \{2, 4\}$

Thus $A = \{3, 5\}$ and $B = \{2, 4\}$

2. Find $A \times B$, $A \times A$ and $B \times A$

i) $A = \{2, -2, 3\}$ and $B = \{1, -4\}$

ii) $A = B = \{p, q\}$

iii) $A = \{m, n\}$; $B = \{f\}$

Solution:

- i. $A \times B = \{2, -2, 3\} \times \{1, -4\}$
 $= \{(2, 1), (2, -4), (-2, 1), (-2, -4), (3, 1), (3, -4)\}$

$A \times A = \{2, -2, 3\} \times \{2, -2, 3\}$
 $= \{(2, 2), (2, -2), (2, 3), (-2, 2), (-2, -2), (-2, 3), (3, 2), (3, -2), (3, 3)\}$

$B \times A = \{1, -4\} \times \{2, -2, 3\}$
 $= \{(1, 2), (1, -2), (1, 3), (-4, 2), (-4, -2), (-4, 3)\}$

- ii. Given $A = B = \{p, q\}$

$A \times B = \{p, q\} \times \{p, q\}$
 $= \{(p, p), (p, q), (q, p), (q, q)\}$

$A \times A = \{p, q\} \times \{p, q\}$
 $= \{(p, p), (p, q), (q, p), (q, q)\}$

$B \times A = \{p, q\} \times \{p, q\}$
 $= \{(p, p), (p, q), (q, p), (q, q)\}$

- iii. $A = \{m, n\}$, $B = \emptyset$

$A \times B = \{(m, n) \times \{\}\} = \{\}$

$A \times A = \{(m, n) \} \times \{m, n\}$
 $= \{(m, m), (m, n), (n, m), (n, n)\}$

$B \times A = \{\} \times \{m, n\} = \{\}$

3. Let $A = \{1, 2, 3\}$ and $B = \{x \mid x \text{ is a prime number less than } 10\}$. Find $A \times B$ and $B \times A$. MAY-22

Solution:

$A = \{1, 2, 3\}$ $B = \{2, 3, 5, 7\}$

$A \times B = \{1, 2, 3\} \times \{2, 3, 5, 7\}$
 $= \{(1, 2), (1, 3), (1, 5), (1, 7), (2, 2), (2, 3), (2, 5), (2, 7), (3, 2), (3, 3), (3, 5), (3, 7)\}$

$B \times A = \{2, 3, 5, 7\} \times \{1, 2, 3\}$
 $= \{(2, 1), (2, 2), (2, 3), (3, 1), (3, 2), (3, 3), (5, 1), (5, 2), (5, 3), (7, 1), (7, 2), (7, 3)\}$

4. If $B \times A = \{(-2, 3), (-2, 4), (0, 3), (0, 4), (3, 3), (3, 4)\}$ find A and B.

Solution:

$A = \{\text{Set of all second coordinates of elements of } B \times A\} \therefore A = \{3, 4\}$

$B = \{\text{Set of all first coordinates of elements of } B \times A\} \therefore B = \{-2, 0, 3\}$

Thus, $A = \{3, 4\}$ $B = \{-2, 0, 3\}$

5. The arrow diagram shows a relationship between the sets P and Q. Write the relation in

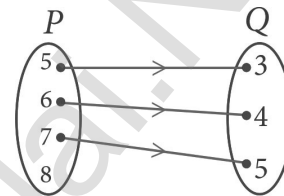

(i) Set builder form (ii) Roster form

(iii) What is the domain and range of R.

Solution:

- i. Set builder form of $R = \{(x, y) \mid y = x - 2, x \in P, y \in Q\}$

ii. Roster form $R = \{(5, 3), (6, 4), (7, 5)\}$

iii. Domain of $R = \{5, 6, 7\}$ and range of $R = \{3, 4, 5\}$

6. Let $X = \{1, 2, 3, 4\}$ and $Y = \{2, 4, 6, 8, 10\}$ and $R = \{(1, 2), (2, 4), (3, 6), (4, 8)\}$. Show that R is a function and find its domain, co-domain and range?

Solution:

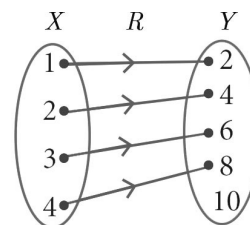

Pictorial representation of R is given diagram,

From the diagram, we see that for each $x \in X$, there exists only one $y \in Y$.

Thus all elements in X have only one image in Y.

Therefore R is a function.

Domain $X = \{1, 2, 3, 4\}$

Co-domain $Y = \{2, 4, 6, 8, 10\}$

Range of $f = \{2, 4, 6, 8\}$

7. Let $A = \{1, 2, 3, 4, \dots, 45\}$ and R be the relation defined as "is square of a number" on A . Write R as a subset of $A \times A$. Also, find the domain and range of R . SEP-21

Solution:

$$A = \{1, 2, 3, \dots, 45\}$$

$$R = \{(1, 1), (2, 4), (3, 9), (4, 16), (5, 25), (6, 36)\}$$

$$R \subset (A \times A)$$

$$\therefore \text{Domain of } R = \{1, 2, 3, 4, 5, 6\}$$

$$\text{Range of } R = \{1, 4, 9, 16, 25, 36\}$$

8. A Relation R is given by the set $\{(x, y) / y = x + 3, x \in \{0, 1, 2, 3, 4, 5\}\}$. Determine its domain and range.

Solution:

$$x = \{0, 1, 2, 3, 4, 5\}$$

$$f(x) = y = x + 3$$

$$f(0) = 3; \quad f(1) = 4; \quad f(2) = 5;$$

$$f(3) = 6; \quad f(4) = 7; \quad f(5) = 8$$

$$\therefore R = \{(0, 3), (1, 4), (2, 5), (3, 6), (4, 7), (5, 8)\}$$

$$\text{Domain of } R = \{0, 1, 2, 3, 4, 5\}$$

$$\text{Range of } R = \{3, 4, 5, 6, 7, 8\}$$

9. Given the function $f: x \rightarrow x^2 - 5x + 6$, evaluate (i) $f(-1)$ (ii) $f(2a)$ (iii) $f(2)$ (iv) $f(x-1)$

Solution:

$$\text{Given: } f: x \rightarrow x^2 - 5x + 6$$

$$\Rightarrow f(x) = x^2 - 5x + 6$$

i. $f(-1) = (-1)^2 - 5(-1) + 6$

$$= 1 + 5 + 6$$

$$= 12$$

ii. $f(2a) = (2a)^2 - 5(2a) + 6$

$$= 4a^2 - 10a + 6$$

iii. $f(2) = (2)^2 - 5(2) + 6$

$$= 4 - 10 + 6$$

$$= 0$$

iv. $f(x-1) = (x-1)^2 - 5(x-1) + 6$

$$= x^2 - 2x + 1 - 5x + 5 + 6$$

$$= x^2 - 7x + 12$$

10. A function f is defined by $f(x) = 3 - 2x$. Find x such that $f(x^2) = (f(x))^2$.

Solution:

$$f(x) = 3 - 2x$$

$$f(x^2) = [f(x)]^2$$

$$3 - 2x^2 = [3 - 2x]^2$$

$$\Rightarrow 3 - 2x^2 = 9 + 4x^2 - 12x$$

$$3 - 2x^2 - 9 - 4x^2 + 12x = 0$$

$$\Rightarrow -6x^2 + 12x - 6 = 0 \div -6$$

$$x^2 - 2x + 1 = 0$$

$$(x-1)(x-1) = 0 \quad x = 1, 1$$

11. Let $A = \{1, 2, 3, 4\}$ and $B = N$.

Let $f: A \rightarrow B$ be defined by $f(x) = x^3$ then, (i) find the range of f (ii) identify the type of function.

Solution:

$$A = \{1, 2, 3, 4\}, B = N$$

$$f: A \rightarrow B, f(x) = x^3$$

$$f(1) = (1)^3 = 1; \quad f(2) = (2)^3 = 8;$$

$$f(3) = (3)^3 = 27; \quad f(4) = (4)^3 = 64$$

i) Range of $f = \{1, 8, 27, 64\}$

ii) It is one-one and into function.

5 Marks

1. If $A = \{1, 3, 5\}$ and $B = \{2, 3\}$ then

(i) find $A \times B$ and $B \times A$.

(ii) Is $A \times B = B \times A$? If not why?

(iii) Show that $n(A \times B) = n(B \times A) = n(A) \times n(B)$

SEP-21

Solution:

$$\text{Given that } A = \{1, 3, 5\} \text{ and } B = \{2, 3\}$$

i. $A \times B = \{1, 3, 5\} \times \{2, 3\}$

$$= \{(1,2), (1,3), (3,2), (3,3), (5,2), (5,3)\}$$

$$\dots\dots\dots(1)$$

$$B \times A = \{2, 3\} \times \{1, 3, 5\}$$

$$= \{(2,1), (2,3), (2,5), (3,1), (3,3), (3,5)\}$$

$$\dots\dots\dots(2)$$

ii. From (1) and (2) we conclude that $A \times B \neq B \times A$ as $(1, 2) \neq (2, 1)$ and $(1, 3) \neq (3, 1)$ etc

iii. $n(A) = 3; n(B) = 2$

From (1) and (2) we observe that,

$$n(A \times B) = n(B \times A) = 6;$$

$$\text{We see that, } n(A) \times n(B) = 3 \times 2 = 6$$

$$\text{Thus, } n(A \times B) = n(B \times A) = n(A) \times n(B).$$

2. Let $A = \{x \in N \mid 1 < x < 4\}$, $B = \{x \in W \mid 0 \leq x < 2\}$ and $C = \{x \in N \mid x < 3\}$. Then verify that

(i) $A \times (B \cup C) = (A \times B) \cup (A \times C)$

(ii) $A \times (B \cap C) = (A \times B) \cap (A \times C)$

Solution:

$$\text{Given } A = \{x \in N \mid 1 < x < 4\} = \{2, 3\},$$

$$B = \{x \in W \mid 0 \leq x < 2\} = \{0, 1\},$$

$$C = \{x \in N \mid x < 3\} = \{1, 2\}$$

i. $A \times (B \cup C) = (A \times B) \cup (A \times C)$
 $B \cup C = \{0, 1\} \cup \{1, 2\} = \{0, 1, 2\}$
 $A \times (B \cup C)$
 $= \{2, 3\} \times \{0, 1, 2\}$
 $= \{(2, 0), (2, 1), (2, 2), (3, 0), (3, 1), (3, 2)\}$ (1)

$A \times B = \{2, 3\} \times \{0, 1\}$
 $= \{(2, 0), (2, 1), (3, 0), (3, 1)\}$
 $A \times C = \{2, 3\} \times \{1, 2\}$
 $= \{(2, 1), (2, 2), (3, 1), (3, 2)\}$
 $(A \times B) \cup (A \times C)$
 $= \{(2, 0), (2, 1), (3, 0), (3, 1)\} \cup \{(2, 1), (2, 2), (3, 1), (3, 2)\}$
 $= \{(2, 0), (2, 1), (2, 2), (3, 0), (3, 1), (3, 2)\}$ (2)

From (1) = (2).

$\therefore A \times (B \cup C) = (A \times B) \cup (A \times C)$ is verified.

ii. $A \times (B \cap C) = (A \times B) \cap (A \times C)$
 $B \cap C = \{0, 1\} \cap \{1, 2\} = \{1\}$
 $A \times (B \cap C) = \{2, 3\} \times \{1\}$
 $= \{(2, 1), (3, 1)\}$ (1)

$A \times B = \{2, 3\} \times \{0, 1\}$
 $= \{(2, 0), (2, 1), (3, 0), (3, 1)\}$
 $A \times C = \{2, 3\} \times \{1, 2\}$
 $= \{(2, 1), (2, 2), (3, 1), (3, 2)\}$
 $(A \times B) \cap (A \times C)$
 $= \{(2, 0), (2, 1), (3, 0), (3, 1)\} \cap \{(2, 1), (2, 2), (3, 1), (3, 2)\}$
 $= \{(2, 1), (3, 1)\}$ (2)

(1) = (2)
 $\therefore A \times (B \cap C) = (A \times B) \cap (A \times C)$
Hence it is Verified

3. If $A = \{5, 6\}$, $B = \{4, 5, 6\}$, $C = \{5, 6, 7\}$, Show that $A \times A = (B \times B) \cap (C \times C)$.

Solution:

Given $A = \{5, 6\}$, $B = \{4, 5, 6\}$, $C = \{5, 6, 7\}$

LHS:

$A \times A = \{5, 6\} \times \{5, 6\}$
 $= \{(5, 5), (5, 6), (6, 5), (6, 6)\}$ (1)

RHS = $(B \times B) \cap (C \times C)$.

$B \times B = \{4, 5, 6\} \times \{4, 5, 6\}$
 $= \{(4, 4), (4, 5), (4, 6), (5, 4), (5, 5), (5, 6), (6, 4), (6, 5), (6, 6)\}$

$C \times C = \{5, 6, 7\} \times \{5, 6, 7\}$
 $= \{(5, 5), (5, 6), (5, 7), (6, 5), (6, 6), (6, 7), (7, 5), (7, 6), (7, 7)\}$

$\therefore (B \times B) \cap (C \times C)$
 $= \{(5, 5), (5, 6), (6, 5), (6, 6)\}$ (2)
 \therefore From (1) and (2). LHS = RHS

4. Given $A = \{1, 2, 3\}$, $B = \{2, 3, 5\}$, $C = \{3, 4\}$ and $D = \{1, 3, 5\}$, check if $(A \cap C) \times (B \cap D) = (A \times B) \cap (C \times D)$ is true?

Solution:

$A \cap C = \{1, 2, 3\} \cap \{3, 4\}$
 $A \cap C = \{3\}$,
 $B \cap D = \{2, 3, 5\} \cap \{1, 3, 5\}$
 $B \cap D = \{3, 5\}$
 $(A \cap C) \times (B \cap D)$
 $= \{3\} \times \{3, 5\} = \{(3, 3), (3, 5)\}$ (1)

$A \times B = \{1, 2, 3\} \times \{2, 3, 5\}$
 $= \{(1, 2), (1, 3), (1, 5), (2, 2), (2, 3), (2, 5), (3, 2), (3, 3), (3, 5)\}$
 $C \times D = \{3, 4\} \times \{1, 3, 5\}$
 $= \{(3, 1), (3, 3), (3, 5), (4, 1), (4, 3), (4, 5)\}$

$(A \times B) \cap (C \times D) = \{(3, 3), (3, 5)\}$ (2)

(1), (2) are equal.

$\therefore (A \cap C) \times (B \cap D) = (A \times B) \cap (C \times D)$

Hence it is verified.

5. Let $A = \{x \in W \mid x < 2\}$, $B = \{x \in N \mid 1 < x \leq 4\}$ and $C = \{3, 5\}$. Verify that

(i) $A \times (B \cup C) = (A \times B) \cup (A \times C)$

(ii) $A \times (B \cap C) = (A \times B) \cap (A \times C)$

SEP-21

(iii) $(A \cup B) \times C = (A \times C) \cup (B \times C)$

Solution:

Given:

$A = \{x \in W \mid x < 2\} \Rightarrow A = \{0, 1\}$

$B = \{x \in N \mid 1 < x \leq 4\}$

$\Rightarrow B = \{2, 3, 4\}$; $C = \{3, 5\}$

i. $A \times (B \cup C) = (A \times B) \cup (A \times C)$

$B \cup C = \{2, 3, 4\} \cup \{3, 5\}$

$B \cup C = \{2, 3, 4, 5\}$

$A \times (B \cup C) = \{0, 1\} \times \{2, 3, 4, 5\}$
 $= \{(0, 2), (0, 3), (0, 4), (0, 5), (1, 2), (1, 3), (1, 4), (1, 5)\}$ (1)

$A \times B = \{0, 1\} \times \{2, 3, 4\}$

$= \{(0, 2), (0, 3), (0, 4), (1, 2), (1, 3), (1, 4)\}$

$A \times C = \{0, 1\} \times \{3, 5\}$

$= \{(0, 3), (0, 5), (1, 3), (1, 5)\}$

$\therefore (A \times B) \cup (A \times C)$

$= \{(0, 2), (0, 3), (0, 4), (0, 5), (1, 2), (1, 3), (1, 4), (1, 5)\}$ (2)

$\therefore (1) = (2)$ Hence Verified.

$$\begin{aligned} \text{ii. } A \times (B \cap C) &= (A \times B) \cap (A \times C) \\ B \cap C &= \{2, 3, 4\} \cap \{3, 5\} = \{3\} \\ A \times (B \cap C) &= \{(0, 3), (1, 3)\} \quad \dots (1) \\ A \times B &= \{0, 1\} \times \{2, 3, 4\} \\ &= \{(0, 2), (0, 3), (0, 4), (1, 2), (1, 3), (1, 4)\} \\ A \times C &= \{0, 1\} \times \{3, 5\} \\ &= \{(0, 3), (0, 5), (1, 3), (1, 5)\} \\ \therefore (A \times B) \cap (A \times C) &= \{(0, 3), (1, 3)\} \quad \dots (2) \\ \therefore (1) &= (2). \text{ Hence Proved.} \end{aligned}$$

$$\begin{aligned} \text{iii. } (A \cup B) \times C &= (A \times C) \cup (B \times C) \\ A \cup B &= \{0, 1\} \cup \{2, 3, 4\} \\ &= \{0, 1, 2, 3, 4\} \\ \therefore (A \cup B) \times C &= \{0, 1, 2, 3, 4\} \times \{3, 5\} \\ &= \{(0, 3), (0, 5), (1, 3), (1, 5), (2, 3), (2, 5), (3, 3), \\ &\quad (3, 5), (4, 3), (4, 5)\} \quad \dots (1) \\ A \times C &= \{0, 1\} \times \{3, 5\} \\ &= \{(0, 3), (0, 5), (1, 3), (1, 5)\} \\ B \times C &= \{2, 3, 4\} \times \{3, 5\} \\ &= \{(2, 3), (2, 5), (3, 3), (3, 5), (4, 3), (4, 5)\} \\ \therefore (A \times C) \cup (B \times C) &= \{(0, 3), (0, 5), (1, 3), (1, 5), (2, 3), (2, 5), \\ &\quad (3, 3), (3, 5), (4, 3), (4, 5)\} \quad \dots (2) \\ \therefore \text{From (1) and (2) LHS} &= \text{RHS.} \end{aligned}$$

6. Let A = The set of all natural numbers less than 8, B = The set of all prime numbers less than 8, C = The set of even prime number. Verify that

$$\begin{aligned} \text{(i) } (A \cap B) \times C &= (A \times C) \cap (B \times C) \quad \text{SEP-20} \\ \text{(ii) } A \times (B - C) &= (A \times B) - (A \times C) \quad \text{MAY-22} \end{aligned}$$

Solution:

$$\begin{aligned} \text{Given } A &= \{1, 2, 3, 4, 5, 6, 7\} \\ B &= \{2, 3, 5, 7\} \quad C = \{2\} \\ \text{To verify } (A \cap B) \times C &= (A \times C) \cap (B \times C) \\ A \cap B &= \{1, 2, 3, 4, 5, 6, 7\} \cap \{2, 3, 5, 7\} \\ &= \{2, 3, 5, 7\} \\ (A \cap B) \times C &= \{2, 3, 5, 7\} \times \{2\} \\ \therefore (A \cap B) \times C &= \{(2, 2), (3, 2), (5, 2), (7, 2)\} \quad \dots (1) \\ A \times C &= \{1, 2, 3, 4, 5, 6, 7\} \times \{2\} \\ &= \{(1, 2), (2, 2), (3, 2), (4, 2), (5, 2), (6, 2), \\ &\quad (7, 2)\} \\ B \times C &= \{2, 3, 5, 7\} \times \{2\} \\ &= \{(2, 2), (3, 2), (5, 2), (7, 2)\} \\ (A \times C) \cap (B \times C) &= \{(2, 2), (3, 2), (5, 2), (7, 2)\} \quad \dots (2) \\ \therefore \text{From (1) and (2), LHS} &= \text{RHS} \end{aligned}$$

$$\begin{aligned} \text{ii. To verify } A \times (B - C) &= (A \times B) - (A \times C) \\ B - C &= \{2, 3, 5, 7\} - \{2\} = \{3, 5, 7\} \\ A \times (B - C) &= \{1, 2, 3, 4, 5, 6, 7\} \times \{3, 5, 7\} \\ &= \{(1, 3), (1, 5), (1, 7), (2, 3), (2, 5), \\ &\quad (2, 7), (3, 3), (3, 5), (3, 7), (4, 3), \\ &\quad (4, 5), (4, 7), (5, 3), (5, 5), (5, 7), \\ &\quad (6, 3), (6, 5), (6, 7), (7, 3), (7, 5), \\ &\quad (7, 7)\} \quad \dots (1) \\ A \times B &= \{1, 2, 3, 4, 5, 6, 7\} \times \{2, 3, 5, 7\} \\ &= \{(1, 2), (1, 3), (1, 5), (1, 7), (2, 2), (2, 3), \\ &\quad (2, 5), (2, 7), (3, 2), (3, 3), (3, 5), (3, 7), \\ &\quad (4, 2), (4, 3), (4, 5), (4, 7), (5, 2), (5, 3), \\ &\quad (5, 5), (5, 7), (6, 2), (6, 3), (6, 5), (6, 7), \\ &\quad (7, 2), (7, 3), (7, 5), (7, 7)\} \\ A \times C &= \{1, 2, 3, 4, 5, 6, 7\} \times \{2\} \\ &= \{(1, 2), (2, 2), (3, 2), (4, 2), (5, 2), (6, 2), \\ &\quad (7, 2)\} \\ (A \times B) - (A \times C) &= \{(1, 3), (1, 5), (1, 7), (2, 3), (2, 5), (2, 7), (3, 3), \\ &\quad (3, 5), (3, 7), (4, 3), (4, 5), (4, 7), (5, 3), (5, 5), \\ &\quad (5, 7), (6, 3), (6, 5), (6, 7), (7, 3), (7, 5), (7, 7)\} \quad \dots (2) \end{aligned}$$

(1), (2) are equal.

$$\therefore A \times (B - C) = (A \times B) - (A \times C).$$

Hence it is verified.

7. Let A = {3, 4, 7, 8} and B = {1, 7, 10}. Which of the following sets are relations from A to B?

$$\begin{aligned} \text{(i) } R_1 &= \{(3, 7), (4, 7), (7, 10), (8, 1)\} \\ \text{(ii) } R_2 &= \{(3, 1), (4, 12)\} \\ \text{(iii) } R_3 &= \{(3, 7), (4, 10), (7, 7), (7, 8), (8, 11), \\ &\quad (8, 7), (8, 10)\} \end{aligned}$$

Solution:

$$\begin{aligned} A \times B &= \{(3, 1), (3, 7), (3, 10), (4, 1), (4, 7), \\ &\quad (4, 10), (7, 1), (7, 7), (7, 10), (8, 1), \\ &\quad (8, 7), (8, 10)\} \end{aligned}$$

i. We note that, $R_1 \subseteq A \times B$.

Thus R_1 is a relation from A and B.

ii. Here $(4, 12) \in R_2$, but $(4, 12) \notin A \times B$.

So R_2 is not a relation from A to B.

iii. Here $(7, 8) \in R_3$, but $(7, 8) \notin A \times B$.

So R_3 is not a relation from A to B.

8. Let A = {1, 2, 3, 7} and B = {3, 0, -1, 7}, which of the following are relation from A to B ?

$$\begin{aligned} \text{(i) } R_1 &= \{(2, 1), (7, 1)\} \quad \text{(ii) } R_2 = \{(-1, 1)\} \\ \text{(iii) } R_3 &= \{(2, -1), (7, 7), (1, 3)\} \\ \text{(iv) } R_4 &= \{(7, -1), (0, 3), (3, 3), (0, 7)\} \end{aligned}$$

Solution:

Given $A = \{1, 2, 3, 7\}$ and $B = \{3, 0, -1, 7\}$

$\therefore A \times B$

$= \{1, 2, 3, 7\} \times \{3, 0, -1, 7\}$

$= \{(1, 3), (1, 0), (1, -1), (1, 7), (2, 3), (2, 0), (2, -1), (2, 7), (3, 3), (3, 0), (3, -1), (3, 7), (7, 3), (7, 0), (7, -1), (7, 7)\}$

i. $R_1 = \{(2, 1), (7, 1)\}$, $(2, 1) \in R_1$

but $(2, 1) \notin A \times B$

$\therefore R_1$ is not a relation from A to B .

ii. $R_2 = \{(-1, 1)\}$, $(-1, 1) \in R_2$

but $(-1, 1) \notin A \times B$

$\therefore R_2$ is not a relation from A to B .

iii. $R_3 = \{(2, -1), (7, 7), (1, 3)\}$

We note that $R_3 \subseteq A \times B$

$\therefore R_3$ is a relation.

iv. $R_4 = \{(7, -1), (0, 3), (3, 3), (0, 7)\}$, $(0, 3)$,

$(0, 7) \in R_4$ but not in $A \times B$.

$\therefore R_4$ is not a relation from A to B .

9. Represent each of the given relations by (a) an arrow diagram, (b) a graph and (c) a set in roster form, wherever possible.

(i) $\{(x, y) | x = 2y, x \in \{2, 3, 4, 5\}, y \in \{1, 2, 3, 4\}\}$

(ii) $\{(x, y) | y = x + 3,$

x, y are natural numbers $< 10\}$

Solution:

i. $\{(x, y) | x = 2y, x \in \{2, 3, 4, 5\}, y \in \{1, 2, 3, 4\}\}$

$x = 2y$

$$f(x) = \frac{x}{2}; \quad f(2) = \frac{2}{2} = 1; \quad f(3) = \frac{3}{2};$$

$$f(4) = \frac{4}{2} = 2; \quad f(5) = \frac{5}{2}$$

a) An Arrow diagram

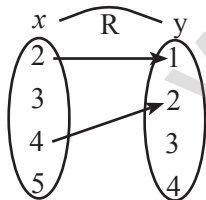

b) Graph

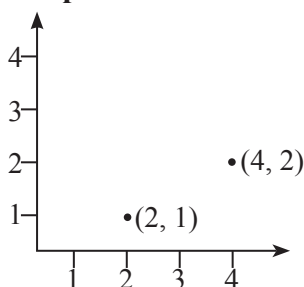

c) Roster Form

$\{(2, 1), (4, 2)\}$

ii. $\{(x, y) | y = x + 3,$

x, y are natural numbers $< 10\}$

Solution:

$$f(x) = x + 3;$$

$$f(1) = 4; \quad f(2) = 5; \quad f(3) = 6;$$

$$f(4) = 7; \quad f(5) = 8; \quad f(6) = 9$$

a) An Arrow diagram

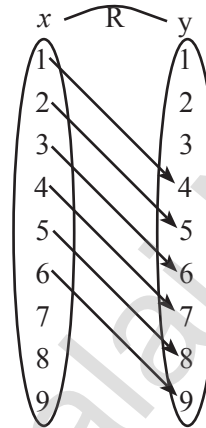

b) Graph

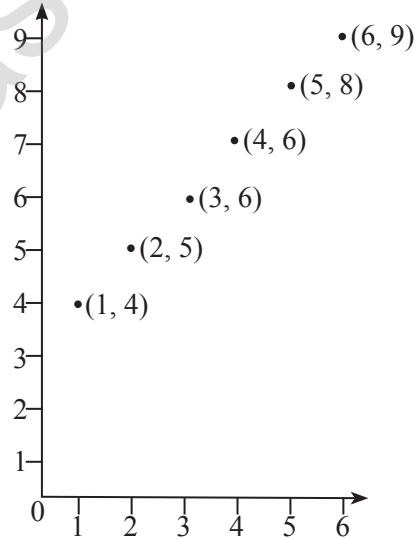

c) Roster Form

$\{(1, 4), (2, 5), (3, 6), (4, 7), (5, 8), (6, 9)\}$

10. A company has four categories of employees given by Assistants (A), Clerks (C), Managers (M) and an Executive Officer (E). The company provide ₹ 10,000, ₹ 25,000, ₹ 50,000 and ₹ 1,00,000 as salaries to the people who work in the categories A, C, M and E respectively. If A_1, A_2, A_3, A_4 and A_5 were Assistants; C_1, C_2, C_3, C_4 were Clerks; M_1, M_2, M_3 were managers and E_1, E_2 were Executive officers and if the relation R is defined by xRy , where x is the salary given to

person y , express the relation R through an ordered pair and an arrow diagram.

Solution:

a) **Ordered Pair:**

$\{(10000, A_1), (10000, A_2), (10000, A_3), (10000, A_4), (10000, A_5), (25000, C_1), (25000, C_2), (25000, C_3), (25000, C_4), (50000, M_1), (50000, M_2), (50000, C_3), (100000, E_1), (100000, E_2)\}$

b) **Arrow Diagram:**

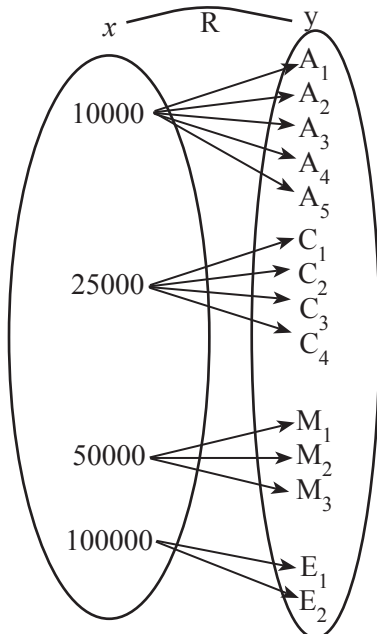

11. Let $A = \{1, 2, 3, 4\}$ and $B = \{2, 5, 8, 11, 14\}$ be two sets. Let $f: A \rightarrow B$ be a function given by $f(x) = 3x - 1$. Represent this function

(i) by arrow diagram

(ii) in a table form

(iii) as a set of ordered pairs

(iv) in a graphical form

SEP-20

Solution:

$A = \{1, 2, 3, 4\}$, $B = \{2, 5, 8, 11, 14\}$

$f(x) = 3x - 1$

$f(1) = 3(1) - 1 = 3 - 1 = 2$;

$f(2) = 3(2) - 1 = 6 - 1 = 5$ $f(3) = 3(3) - 1 = 9 - 1 = 8$;

$f(4) = 3(4) - 1 = 12 - 1 = 11$.

$R = \{(1, 2), (2, 5), (3, 8), (4, 11)\}$

i) **Arrow Diagram**

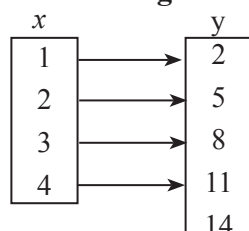

ii) **Table**

x	1	2	3	4
y	2	5	8	11

iii) **Set of Ordered pairs**

$\{(1, 2), (2, 5), (3, 8), (4, 11)\}$

iv) **Graphical Form**

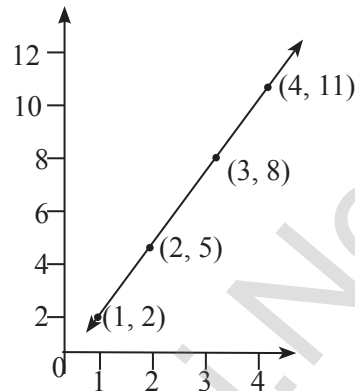

12. Let f be a function $f: \mathbb{N} \rightarrow \mathbb{N}$ be defined by $f(x) = 3x + 2$, $x \in \mathbb{N}$

(i) Find the images of 1, 2, 3

(ii) Find the pre-images of 29, 53

(iii) Identify the type of function

Solution:

The function $f: \mathbb{N} \rightarrow \mathbb{N}$ be defined by

$f(x) = 3x + 2$

i. If $x = 1$, $f(1) = 3(1) + 2 = 5$

If $x = 2$, $f(2) = 3(2) + 2 = 8$; If $x = 3$, $f(3) = 3(3) + 2 = 11$

The images of 1, 2, 3 are 5, 8, 11 respectively.

ii. If x is the pre-image of 29, then $f(x) = 29$.

Hence $3x + 2 = 29$; $3x = 27 \Rightarrow x = 9$.

Similarly, if x is the pre-image of 53 then $f(x) = 53$. Hence $3x + 2 = 53$

$3x = 53 - 2 \Rightarrow 3x = 51 \Rightarrow x = 17$.

Thus the pre-image of 29 and 53 are 9 and 17 respectively.

iii. Since different elements of \mathbb{N} have different images in the co-domain, the function f is one-one function. The co-domain of f is \mathbb{N} . But the range of $f = \{5, 8, 11, 14, 17, \dots\}$ is a proper subset of \mathbb{N} . Therefore f is not an onto function. That is, f is an into function. Thus f is one-one and into functions.

13. Let $f: A \rightarrow B$ be a function defined by

$f(x) = \frac{x}{2} - 1$ where $A = \{2, 4, 6, 10, 12\}$,

$B = \{0, 1, 2, 4, 5, 9\}$. Represent f by

- i) set of ordered pairs ii) a table
iii) an arrow diagram iv) a graph

Solution:

$$\text{Given } f(x) = \frac{x}{2} - 1$$

$$x = 2 \Rightarrow f(2) = 1 - 1 = 0$$

$$x = 4 \Rightarrow f(4) = 2 - 1 = 1$$

$$x = 6 \Rightarrow f(6) = 3 - 1 = 2$$

$$x = 10 \Rightarrow f(10) = 5 - 1 = 4$$

$$x = 12 \Rightarrow f(12) = 6 - 1 = 5$$

- i) **Set of Ordered Pairs:**

$$f = \{(2, 0), (4, 1), (6, 2), (10, 4), (12, 5)\}$$

- ii) **Table**

x	2	4	6	10	12
f(x)	0	1	2	4	5

- iii) **Arrow Diagram**

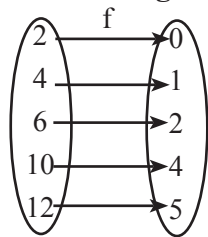

- iv) **Graph**

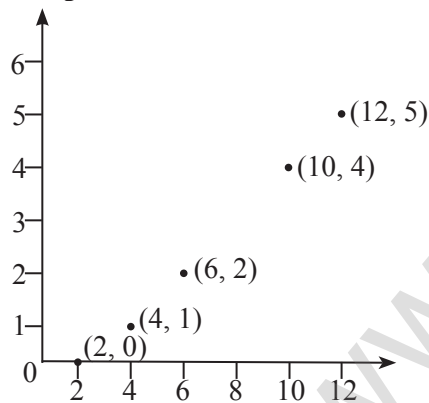

14. Represent the function

$$f = \{(1, 2), (2, 2), (3, 2), (4, 3), (5, 4)\}$$
 through

- (i) an arrow diagram
(ii) a table form
(iii) a graph

Solution:

- i) **Arrow Diagram**

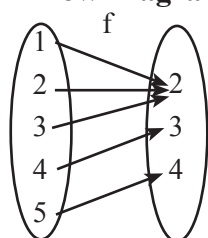

- ii) **Table Form:**

x	1	2	3	4	5
f(x)	2	2	2	3	4

- iii) **Graph**

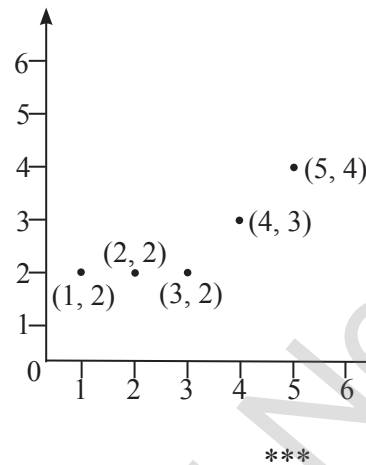

2. Numbers and Sequences

2 Marks

1. 'a' and 'b' are two positive integers such that $a^b \times b^a = 800$. Find 'a' and 'b'.

Solution:

$$800 = a^b \times b^a$$

2	800
2	400
2	200
2	100
2	50
5	25
	5

$$800 = 2 \times 2 \times 2 \times 2 \times 2 \times 5 \times 5$$

$$= 2^5 \times 5^2$$

$$\therefore a = 2, b = 5 \text{ (or) } a = 5, b = 2$$

2. Find the HCF of 252525 and 363636.

Solution:

2	363636	5	252525
2	181818	5	50505
3	90909	3	10101
3	30303	7	3367
3	10101	13	481
7	3367	37	37
13	481		1
37	37		
	1		

$$252525 = 3 \times 5^2 \times 7 \times 13 \times 37$$

$$363636 = 2^3 \times 3^3 \times 7 \times 13 \times 37$$

$$\text{H.C.F of } 252525 \text{ and } 363636$$

$$= 3 \times 7 \times 13 \times 37$$

$$= 10101.$$

3. If $13824 = 2^a \times 3^b$ then find a and b. (MAY-22)

Solution:

$$\begin{array}{r} 2 \overline{) 13824} \\ 2 \overline{) 6912} \\ 2 \overline{) 3456} \\ 2 \overline{) 1728} \\ 2 \overline{) 864} \\ 2 \overline{) 432} \\ 2 \overline{) 216} \\ 2 \overline{) 108} \\ 2 \overline{) 54} \\ 3 \overline{) 27} \\ 3 \overline{) 9} \\ 3 \end{array}$$

$$\Rightarrow 13824 = 2^9 \times 3^3$$

$$\therefore a = 9, b = 3$$

4. Find the LCM and HCF of 408 and 170 by applying the fundamental theorem of arithmetic.

Solution:

$$\begin{array}{r} 2 \overline{) 408} \quad 2 \overline{) 170} \\ 2 \overline{) 204} \quad 5 \overline{) 85} \\ 2 \overline{) 102} \quad \underline{17} \\ 3 \overline{) 51} \\ \underline{17} \end{array}$$

$$408 = 2^3 \times 3 \times 17$$

$$170 = 2 \times 5 \times 17$$

$$\text{H.C.F. of } 408 \text{ \& } 170 = 2 \times 17 = 34$$

$$\text{L.C.M. of } 408 \text{ \& } 170 = 2^3 \times 3 \times 5 \times 17$$

$$= 2040$$

5. The general term of a sequence is defined as

$$a_n = \begin{cases} n(n+3); & n \in N \text{ is odd} \\ n^2 + 1; & n \in N \text{ is even} \end{cases}$$

Find the eleventh and eighteenth terms.

Solution:

To find a_{11} , since 11 is odd,
we put $n = 11$ in
 $a_n = n(n+3)$
Thus,
the eleventh term $a_{11} = 11(11+3) = 154$.
To find a_{18} , since 18 is even,

we put $n = 18$ in

$$a_n = n^2 + 1$$

Thus, the eighteenth term $a_{18} = 18^2 + 1 = 325$.

6. Find the indicated terms of the sequences whose n^{th} terms are given by

(i) $a_n = \frac{5n}{n+2}$; a_6 and a_{13}

(ii) $a_n = -(n^2 - 4)$; a_4 and a_{11}

Solution:

i. $a_n = \frac{5n}{n+2}$

$$a_6 = \frac{30}{8} = \frac{15}{4}; \quad a_{13} = \frac{65}{15} = \frac{13}{3}$$

ii. $a_n = -(n^2 - 4)$

$$a_4 = -(16 - 4) = -12;$$

$$a_{11} = -(121 - 4) = -117$$

7. Find a_8 and a_{15} whose n^{th} term is

$$a_n = \begin{cases} \frac{n^2 - 1}{n + 3}; & n \text{ is even, } n \in N \\ \frac{n^2}{2n + 1}; & n \text{ is odd, } n \in N \end{cases}$$

Solution:

To find a_8 here n is even, so $a_n = \frac{n^2 - 1}{n + 3}$

$$a_8 = \frac{64 - 1}{11} = \frac{63}{11}$$

To find a_{15} , here n is odd, so $a_n = \frac{n^2}{2n + 1}$

$$a_{15} = \frac{(15)^2}{30 + 1} = \frac{225}{31}$$

8. Find the 19th term of an A.P. $-11, -15, -19, \dots$

Solution:

General Form of an A.P. is $t_n = a + (n-1)d$

$$a = -11; d = -15 + 11 = -4; n = 19$$

$$t_{19} = -11 + 18(-4)$$

$$= -11 - 72$$

$$t_{19} = -83$$

9. Which term of an A.P. $16, 11, 6, 1, \dots$ is -54 ?

(MAY-22)

Solution:

$$n = \left(\frac{l - a}{d} \right) + 1$$

$$a = 16; d = 11 - 16 = -5; l = -54$$

$$n = \frac{-54 - 16}{-5} + 1 = \frac{-70}{-5} + 1$$

$$n = 14 + 1$$

$$n = 15$$

10. Find the middle term(s) of an A.P. 9, 15, 21, 27, ..., 183.

Solution:

$$a = 9, d = 6, l = 183$$

$$n = \left(\frac{l-a}{d}\right) + 1$$

$$= \frac{183-9}{6} + 1 = \frac{174}{6} + 1 = 29 + 1 = 30$$

∴ 15 and 16 are the middle terms.

$$t_n = a + (n-1)d$$

$$\begin{aligned} \therefore t_{15} &= a + 14d & t_{16} &= a + 15d \\ &= 9 + 14(6) & &= 9 + 15(6) \\ &= 9 + 84 & &= 9 + 90 \\ &= 93 & &= 99 \end{aligned}$$

∴ 93, 99 are the middle terms of A.P.

11. If $3 + k$, $18 - k$, $5k + 1$ are in A.P. then find k .

SEP-21

Solution:

$3 + k$, $18 - k$, $5k + 1$ is a A.P

$$\begin{aligned} t_2 - t_1 &= t_3 - t_2 \\ (18 - k) - (3 + k) &= (5k + 1) - (18 - k) \\ 15 - 2k &= 6k - 17 \\ -2k - 6k &= -17 - 15 \\ -8k &= -32 \\ k &= 4 \end{aligned}$$

12. In a theatre, there are 20 seats in the front row and 30 rows were allotted. Each successive row contains two additional seats than its front row. How many seats are there in the last row?

Solution:

First Term, $a = 20$

Common Difference, $d = 2$

∴ Number of seats in the last row

$$\begin{aligned} &= t_n = a + (n-1)d \\ t_{30} &= a + 29d = 20 + 29(2) = 20 + 58 = 78 \end{aligned}$$

13. Write an A.P. whose first term is 20 and common difference is 8.

Solution:

First Term, $a = 20$;

Common Difference, $d = 8$

Arithmetic Progression is $a, a+d, a+3d, \dots$

In this case,

we get $20, 20 + 8, 20 + 2(8), 20 + 3(8), \dots$

So, the required A.P. is $20, 28, 36, 44, \dots$

14. Find the number of terms in the A.P. 3, 6, 9, 12, ..., 111.

SEP-21

Solution:

First term $a = 3$,

Common difference $d = 6 - 3 = 3$,

Last term, $l = 111$

We know that, $n = \left(\frac{l-a}{d}\right) + 1$

$$n = \left(\frac{111-3}{3}\right) + 1 = 37$$

Thus the A.P. contains 37 terms.

15. Write the first three terms of the G.P. whose first term and the common ratio are given below.

(i) $a = 6, r = 3$ (ii) $a = \sqrt{2}, r = \sqrt{2}$

(iii) $a = 1000, r = \frac{2}{5}$

Solution:

- i. General Form of an G.P. $\Rightarrow a, ar, ar^2, \dots$

$$\begin{aligned} a = 6, r = 3 \text{ G.P.} &\Rightarrow 6, 6(3), 6(3)^2 \dots \\ &\Rightarrow 6, 18, 54, \dots \end{aligned}$$

- ii. G.P. $\Rightarrow a, ar, ar^2, \dots$

$$\begin{aligned} a = \sqrt{2}, r = \sqrt{2} \\ \text{G.P.} &\Rightarrow \sqrt{2}, \sqrt{2} \cdot \sqrt{2}, \sqrt{2} (\sqrt{2})^2 \\ &\Rightarrow \sqrt{2}, 2, 2\sqrt{2} \end{aligned}$$

- iii. G.P. $\Rightarrow a, ar, ar^2, \dots$

$$\begin{aligned} a = 1000, r = \frac{2}{5} \\ \text{G.P.} &\Rightarrow 1000, 1000 \times \frac{2}{5}, 1000 \times \left(\frac{2}{5}\right)^2 \dots \\ \text{G.P.} &\Rightarrow 1000, 400, 160, \dots \end{aligned}$$

16. In a G.P. 729, 243, 81, ... find t_7 .

Solution:

$$\begin{aligned} t_n &= ar^{n-1} \\ a = 729, r &= \frac{243}{729} = \frac{1}{3}, n = 7 \end{aligned}$$

$$t_7 = 729 \times \left(\frac{1}{3}\right)^{7-1}$$

$$t_7 = 729 \times \left(\frac{1}{3}\right)^6$$

$$t_7 = 729 \times \frac{1}{3} \times \frac{1}{3} \times \frac{1}{3} \times \frac{1}{3} \times \frac{1}{3} \times \frac{1}{3}$$

17. Find x so that $x + 6$, $x + 12$ and $x + 15$ are consecutive terms of a Geometric Progression.

Solution:

Given $x + 6$, $x + 12$ and $x + 15$ are consecutive terms of a G.P.

$$\begin{aligned}\frac{t_2}{t_1} &= \frac{t_3}{t_2} \\ \frac{x+12}{x+6} &= \frac{x+15}{x+12} \\ (x+12)^2 &= (x+6)(x+15) \\ x^2 + 24x + 144 &= x^2 + 21x + 90 \\ 24x - 21x &= 90 - 144 \\ 3x &= -54 \\ x &= -\frac{54}{3} = -18\end{aligned}$$

18. Find the number of terms in the following G.P.

(i) 4, 8, 16, ..., 8192?

(ii) $\frac{1}{3}, \frac{1}{9}, \frac{1}{27}, \dots, \frac{1}{2187}$

Solution:

i. G.P. $\Rightarrow 4, 8, 16, \dots, 8192$.

Here $a = 4, r = 2, t_n = 8192$

$$ar^{n-1} = t_n \Rightarrow 4(2)^{n-1} = 8192;$$

$$2^{n-1} = \frac{8192}{4} = 2048$$

$$2^{n-1} = 2^{11}; n-1 = 11$$

$$\Rightarrow n = 12$$

ii. G.P. $\Rightarrow \frac{1}{3}, \frac{1}{9}, \frac{1}{27}, \dots, \frac{1}{2187}$.

Here $a = \frac{1}{3}, r = \frac{1}{3}, t_n = \frac{1}{2187}$

$$\left(\frac{1}{3}\right) \left(\frac{1}{3}\right)^{n-1} = \frac{1}{2187}$$

$$\left(\frac{1}{3}\right)^{n-1} = \frac{1}{2187} \times 3$$

$$\left(\frac{1}{3}\right)^{n-1} = \frac{1}{729} = \left(\frac{1}{3}\right)^6;$$

$$n-1 = 6 \Rightarrow n = 7$$

19. In a G.P. the 9th term is 32805 and 6th term is 1215. Find the 12th term.

Solution:

From the given

$$t_9 = 32805 \Rightarrow ar^8 = 32805 \quad \dots (1)$$

$$t_6 = 1215 \Rightarrow ar^5 = 1215 \quad \dots (2)$$

$$(1) \div (2) \Rightarrow r^3 = 27 \Rightarrow r = 3$$

$$(2) \Rightarrow a(3)^5 = 1215 \Rightarrow a = 5$$

To find t_{12} ,

$$t_n = ar^{n-1}$$

$$t_{12} = (5)(3)^{11}$$

20. Find the first term of a G.P. in which $S_6 = 4095$ and $r = 4$.

Solution:

Common ratio, $= 4 > 1$,

Sum of first 6 terms $S_6 = 4095$

$$\text{Hence, } S_n = \frac{a(r^n - 1)}{r - 1} = 4095$$

$$r = 4, \frac{a(4^6 - 1)}{4 - 1} = 4095$$

$$\Rightarrow a \times \frac{4095}{3} = 4095$$

First term, $a = 3$.

21. Find the value of

$1 + 2 + 3 + \dots + 50$

Solution:

$$1 + 2 + 3 + \dots + 50$$

$$\text{Using } 1 + 2 + 3 + \dots + n = \frac{n(n+1)}{2}$$

$$1 + 2 + 3 + \dots + 50 = \frac{50 \times (50+1)}{2} = 1275$$

22. Find the sum of the following series

$1 + 2 + 3 + \dots + 60$

Solution:

$$1 + 2 + 3 + \dots + 60 = \frac{n(n+1)}{2}$$

$$= \frac{60 \times 61}{2}$$

$$= 30 \times 61 = 1830$$

23. Find the sum of

(i) $1 + 3 + 5 + \dots$ to 40 terms

(ii) $2 + 4 + 6 + \dots$ 80

(iii) $1 + 3 + 5 + \dots + 55$

Solution:

i. $1 + 3 + 5 + \dots + n$ terms $= n^2$

$$1 + 3 + 5 + \dots + 40 \text{ terms} = (40)^2 = 1640$$

ii. $2 + 4 + 6 + \dots + 80$

$$= 2 [1 + 2 + 3 + \dots + 40]$$

$$= 2 \left[\frac{n(n+1)}{2} \right] = 40 \times 41 = 1640$$

iii. $1 + 3 + 5 + \dots + 55$

Here the number of terms is not given.

Now, we have to find the number of terms using the formula.

$$n = \frac{(55-1)}{2} + 1 = 28$$

Therefore,

$$1 + 3 + 5 + \dots + 55 = (28)^2 = 784$$

24. Find the sum of

(i) $1^2 + 2^2 + \dots + 19^2$

(ii) $5^2 + 10^2 + 15^2 + \dots + 105^2$

Solution:

i. $1^2 + 2^2 + \dots + 19^2$

$$= \frac{n(n+1)(2n+1)}{6}$$

$$= \frac{19 \times (19+1)(2 \times 19+1)}{6}$$

$$= \frac{19 \times 20 \times 39}{6} = 2170$$

ii. $5^2 + 10^2 + 15^2 + \dots + 105^2$
 $= 5^2(1^2 + 2^2 + 3^2 + \dots + 21^2)$

$$= 25 \times \frac{21 \times (21+1) \times (2 \times 21+1)}{6}$$

$$= 25 \times \frac{21 \times 22 \times 43}{6} = 82775$$

25. Find the sum of $1^3 + 2^3 + 3^3 + \dots + 16^3$

Solution:

$$1^3 + 2^3 + 3^3 + \dots + n^3 = \left[\frac{n(n+1)}{2} \right]^2$$

$$1^3 + 2^3 + 3^3 + \dots + 16^3 = \left[\frac{16 \times 17}{2} \right]^2$$

$$= [136]^2 = 18496$$

26. If $1 + 2 + 3 + \dots + n = 666$ then find n.

Solution:

$$1 + 2 + 3 + \dots + n = 666$$

$$\frac{n(n+1)}{2} = 666$$

$$n^2 + n = 1332$$

$$n^2 + n - 1332 = 0$$

$$(n - 36)(n + 37) = 0$$

$$n = -37 \text{ or } n = 36$$

But $n \neq -37$ (Since n is a natural number)

Hence $n = 36$.

27. If $1 + 2 + 3 + \dots + k = 325$, then find $1^3 + 2^3 + 3^3 + \dots + k^3$.

Solution:

$$1 + 2 + 3 + \dots + k = \frac{k(k+1)}{2} = 325$$

$$1^3 + 2^3 + 3^3 + \dots + k^3$$

$$= \left[\frac{k(k+1)}{2} \right]^2 = (325)^2 = 105625$$

28. If $1^3 + 2^3 + 3^3 + \dots + k^3 = 44100$ then find $1 + 2 + 3 + \dots + k$.

Solution:

$$1^3 + 2^3 + 3^3 + \dots + k^3 = 44100 = \left[\frac{k(k+1)}{2} \right]^2$$

$$1 + 2 + 3 + \dots + k = \frac{k(k+1)}{2} = 210$$

29. How many terms of the series $1^3 + 2^3 + 3^3 + \dots$ should be taken to get the sum 14400?

Solution:

$$1^3 + 2^3 + 3^3 + \dots + k^3 = \left[\frac{k(k+1)}{2} \right]^2 = 14400$$

$$\Rightarrow \frac{k(k+1)}{2} = \sqrt{14400} = 120$$

$$k(k+1) = 240$$

$$k^2 + k - 240 = 0$$

$$(k - 15)(k + 16) = 0$$

$$k = +15 \text{ or } k = -16$$

k can't be negative

$$\therefore k = 15$$

5 Marks

1. If $p_1^{x_1} \times p_2^{x_2} \times p_3^{x_3} \times p_4^{x_4} = 113400$ where p_1, p_2, p_3, p_4 are primes in ascending order and x_1, x_2, x_3, x_4 are integers, find the value of p_1, p_2, p_3, p_4 and x_1, x_2, x_3, x_4

Solution:

2	113400
2	56700
2	28350
3	14175
3	4725
3	1575
3	525
5	175
5	35
7	7
	1

$$113400 = 2^3 \times 3^4 \times 5^2 \times 7^1$$

$$\therefore P_1 = 2, P_2 = 3, P_3 = 5, P_4 = 7$$

$$x_1 = 3, x_2 = 4, x_3 = 2, x_4 = 1$$

2. If $a_1 = 1, a_2 = 1$ and $a_n = 2a_{n-1} + a_{n-2}, n \geq 3, n \in \mathbb{N}$, then find the first six terms of the sequence.

Solution:

$$\text{Given } a_1 = a_2 = 1 \text{ and } a_n = 2a_{n-1} + a_{n-2}$$

$$a_3 = 2a_2 + a_1 = 2(1) + 1 = 3;$$

$$a_4 = 2a_3 + a_2 = 2(3) + 1 = 7$$

$$a_5 = 2a_4 + a_3 = 2(7) + 3 = 17;$$

$$a_6 = 2a_5 + a_4 = 2(17) + 7 = 41$$

3. Find x , y and z , given that the numbers x , 10 , y , 24 , z are in A.P.

Solution:

A.P. $\Rightarrow x, 10, y, 24, z$

$$\text{That is } y = \frac{10+24}{2} = \frac{34}{2} = 17$$

\therefore A.P. = $x, 10, 17, 24, z$

Here we know that $d = 17 - 10 = 7$

$$\therefore x = 10 - 7 = 3$$

$$z = 24 + 7 = 31$$

$$\therefore x = 3, y = 17, z = 31.$$

4. Find the sum to n terms of the series $5 + 55 + 555 + \dots$

Solution:

$$S_n = 5 + 55 + 555 + \dots + n \text{ terms}$$

$$= 5 [1 + 11 + 111 + \dots + n \text{ terms}]$$

$$= \frac{5}{9} [9 + 99 + 999 + \dots + n \text{ terms}]$$

$$= \frac{5}{9} [10 - 1 + 100 - 1 + 1000 - 1 + \dots + n \text{ terms}]$$

$$= \frac{5}{9} [(10 + 100 + 1000 + \dots) - (1 + 1 + 1 + \dots)]$$

$$= \frac{5}{9} \left[\frac{10(10^n - 1)}{9} - n \right]$$

$$= \frac{50}{81} \left[(10^n - 1) - \frac{5}{9}n \right]$$

5. Find the sum to n terms of the series
(i) $0.4 + 0.44 + 0.444 + \dots$ to n terms
(ii) $3 + 33 + 333 + \dots$ to n terms

Solution:

- i. $0.4 + 0.44 + 0.444 + \dots$ n terms

$$= \frac{4}{10} + \frac{44}{100} + \frac{444}{1000} + \dots n \text{ terms}$$

$$= 4 \left[\frac{1}{10} + \frac{11}{100} + \frac{111}{1000} + \dots n \text{ terms} \right]$$

$$= \frac{4}{9} \left[\frac{9}{10} + \frac{99}{100} + \frac{999}{1000} + \dots n \text{ terms} \right]$$

$$= \frac{4}{9} \left[\left(1 - \frac{1}{10}\right) + \left(1 - \frac{1}{100}\right) + \left(1 - \frac{1}{1000}\right) + \dots n \text{ terms} \right]$$

$$= \frac{4}{9} [(1+1+1+\dots n \text{ terms}) - \left(\frac{1}{10} + \frac{11}{100} + \frac{111}{1000} + \dots n \text{ terms} \right)]$$

$$= \frac{4}{9} \left[n - \frac{1}{10} \left[\frac{1 - \left(\frac{1}{10}\right)^n}{1 - \frac{1}{10}} \right] \right] = \frac{4}{9} \left[n - \frac{1}{9} \left(1 - \left(\frac{1}{10}\right)^n \right) \right]$$

- ii. $3 + 33 + 333 + \dots$ n

$$= 3(1 + 11 + 111 + \dots + n \text{ terms})$$

$$= \frac{3}{9} (9 + 99 + 999 + \dots + n \text{ terms})$$

$$= \frac{3}{9} ((10-1) + (100-1) + (1000-1) + \dots + n \text{ terms})$$

$$= \frac{3}{9} (10 + 100 + 1000 + \dots + n \text{ terms})$$

$$- (1 + 11 + 111 + \dots + n \text{ terms})$$

$$= \frac{3}{9} \left(10 \left(\frac{10^n - 1}{9} \right) - n \right)$$

$$= \frac{30}{81} (10n - 1) - \frac{3n}{9}$$

6. Find the sum of the Geometric series

$$3 + 6 + 12 + \dots + 1536$$

Solution:

$$3 + 6 + 12 + \dots + 1536$$

$$a = 3, r = 2$$

$$t_n = 1536$$

$$ar^{n-1} = 1536$$

$$3(2)^{n-1} = 1536$$

$$3(2)^{n-1} = 3(2)^9$$

$$2^{n-1} = 2^9$$

$$n-1 = 9$$

$$\therefore n = 10$$

To find S_n ,

$$S_n = \frac{a(r^n - 1)}{r - 1} \Rightarrow S_{10} = \frac{3(2^{10} - 1)}{2 - 1}$$

$$= 3(1023) = 3069$$

7. Find the value of $16 + 17 + 18 + \dots + 75$

Solution:

$$16 + 17 + 18 + \dots + 75$$

$$= (1 + 2 + 3 + \dots + 75) - (1 + 2 + 3 + \dots + 15)$$

$$= \frac{75(75+1)}{2} - \frac{15(15+1)}{2}$$

$$= 2850 - 120$$

$$= 2730$$

8. Find the sum of $9^3 + 10^3 + \dots + 21^3$

Solution:

$$\begin{aligned} & 9^3 + 10^3 + \dots + 21^3 \\ &= (1^3 + 2^3 + 3^3 \dots + 21^3) - (1^3 + 2^3 + 3^3 \dots + 8^3) \\ &= \left[\frac{21 \times (21+1)}{2} \right]^2 - \left[\frac{8 \times (8+1)}{2} \right]^2 \\ &= (231)^2 - (36)^2 \\ &= 52065 \end{aligned}$$

9. Find the sum of the following series

(i) $6^2 + 7^2 + 8^2 + \dots + 21^2$

(ii) $10^3 + 11^3 + 12^3 + \dots + 20^3$

Solution:

i. $6^2 + 7^2 + 8^2 + \dots + 21^2$

$$\begin{aligned} &= (1^2 + 2^2 + 3^2 \dots + 21^2) - (1^2 + 2^2 + 3^2 + \dots + 5^2) \\ &= \frac{21 \times (21+1)(42+1)}{6} - \frac{5 \times (5+1)(10+1)}{6} \\ &= \frac{21 \times 22 \times 43}{6} - \frac{5 \times 6 \times 11}{6} \\ &= 3311 - 55 = 3256 \end{aligned}$$

ii. $10^3 + 11^3 + 12^3 + \dots + 20^3$

$$\begin{aligned} &= 1^3 + 2^3 + 3^3 + \dots + 20^3 - 1^3 - 2^3 - 3^3 - \dots - 9^3 \\ &= \left[\frac{20 \times 21}{6} \right]^2 - \left[\frac{9 \times 10}{3} \right]^2 \\ &= [210]^2 - (45)^2 \\ &= 44100 - 2025 = 42075 \end{aligned}$$

10. The sum of the cubes of the first n natural numbers is 2025, then find the value of n .

Solution:

$$\begin{aligned} 1^2 + 2^2 + 3^2 + \dots + n^2 &= 285 \\ \frac{n(n+1)(2n+1)}{2 \times 3} &= 285 \\ \frac{n(n+1)(2n+1)}{6} &= 285 \\ n(n+1)(2n+1) &= 285 \times 6 \quad \dots (1) \\ 1^3 + 2^3 + 3^3 + \dots + n^3 &= 2025 \\ \left[\frac{n(n+1)}{2} \right]^2 &= 2025 \\ \frac{n(n+1)}{2} &= \sqrt{2025} = 45 \\ n(n+1) &= 45 \times 2 \quad \dots (2) \end{aligned}$$

$$\frac{(1)}{(2)} \Rightarrow \frac{n(n+1)(2n+1)}{n(n+1)} = \frac{285 \times 6}{45 \times 2}$$

$$2n + 1 = 19$$

$$2n = 19 - 1$$

$$\Rightarrow 2n = 18$$

$$\therefore n = 9$$

11. Rekha has 15 square colour papers of sizes 10 cm, 11 cm, 12 cm, ..., 24 cm. How much area can be decorated with these colour papers?

Solution:

The Required Area

$$= 10^2 + 11^2 + 12^2 + \dots + 24^2$$

$$\text{Area} = (1^2 + 2^2 + 3^2 + \dots + 24^2)$$

$$- (1^2 + 2^2 + \dots + 9^2)$$

$$= \frac{n(n+1)(2n+1)}{6} - \frac{n(n+1)(2n+1)}{6}$$

$$= \frac{24 \times 25 \times 49}{6} - \frac{9 \times 10 \times 19}{6}$$

$$= 4900 - 285 = 4615 \text{ cm}^2$$

Therefore Rekha has 4615 cm² colour paper.

She can decorate 4615cm² area with these colour papers.

12. Find the sum of $15^2 + 16^2 + 17^2 + \dots + 28^2$

$$15^2 + 16^2 + 17^2 + \dots + 28^2$$

$$= (1^2 + 2^2 + 3^2 \dots + 28^2)$$

$$- (1^2 + 2^2 + 3^2 \dots + 14^2)$$

$$= \frac{n(n+1)(2n+1)}{6} - \frac{n(n+1)(2n+1)}{6}$$

$$= \frac{28 \times 29 \times 57}{2 \times 3} - \frac{14 \times 15 \times 29}{2 \times 3}$$

$$= 14 \times 29 \times 19 - 7 \times 5 \times 29$$

$$= 7714 - 1015 = 6699$$

3. Algebra

2 Marks

1. Find the LCM of the given polynomials

(i) $4x^2y, 8x^3y^2$

(ii) $9a^3b^2, 12a^2b^2c$

(iii) $16m, 12m^2n^2, 8n^2$

(iv) $p^2 - 3p + 2, p^2 - 4$

(v) $2x^2 - 5x - 3, 4x^2 - 36$

(vi) $(2x^2 - 3xy)^2, (4x - 6y)^3, 8x^3 - 27y^3$

Solution:

i. $4x^2y, 8x^3y^2$

$$4x^2y = 2^2x^2y$$

$$8x^3y^2 = 2^3x^3y^2$$

$$\therefore \text{LCM}(4x^2y, 8x^3y^2) = 2^3x^3y^2 = 8x^3y^2$$

ii. $9a^3b^2, 12a^2b^2c$

$$9a^3b^2 = (1)(3)^2 a^3b^2$$

$$12a^2b^2c = 2^2 \times 3 \times a^2 \times b^2 \times c$$

$$\therefore \text{LCM}(9a^3b^2, 12a^2b^2c)$$

$$= (1) \times 2^2 \times 3^2 \times a^3 \times b^2 \times c = 36a^3b^2c$$

iii. $16m, 12m^2n^2, 8n^2$

$$16m = 2^4 \times m$$

$$12m^2n^2 = 2^2 \times 3 \times m^2 \times n^2$$

$$8n^2 = 2^3 \times n^2$$

$$\therefore \text{LCM}(16m, 12m^2n^2, 8n^2)$$

$$= 2^4 \times 3 \times m^2 \times n^2 = 48m^2n^2$$

iv. $p^2 - 3p + 2, p^2 - 4$

$$p^2 - 3p + 2 = (p - 1)(p - 2)$$

$$p^2 - 4 = (p + 2)(p - 2)$$

$$\therefore \text{LCM}(p^2 - 3p + 2, p^2 - 4)$$

$$= (p - 1)(p + 2)(p - 2)$$

v. $2x^2 - 5x - 3, 4x^2 - 36$

$$2x^2 - 5x - 3 = (x - 3)(2x + 1)$$

$$4x^2 - 36 = 4(x + 3)(x - 3)$$

$$\therefore \text{LCM}(2x^2 - 5x - 3, 4x^2 - 36)$$

$$= 4(x - 3)(x + 3)(2x + 1)$$

vi. $(2x^2 - 3xy)^2, (4x - 6y)^3, 8x^3 - 27y^3$

$$(2x^2 - 3xy)^2 = x^2(2x - 3y)^2$$

$$(4x - 6y)^3 = 2^3(2x - 3y)^3$$

$$8x^3 - 27y^3 = (2x)^3 - (3y)^3$$

$$= (2x - 3y)(4x^2 + 6xy + 9y^2)$$

$$\therefore \text{LCM}((2x^2 - 3xy)^2, (4x - 6y)^3, (8x^3 - 27y^3))$$

$$= 2^3 \times x^2 \times (2x - 3y)^3 (4x^2 + 6xy + 9y^2)$$

$$= 8x^2(2x - 3y)^3 (4x^2 + 6xy + 9y^2)$$

2. Simplify:

i) $\frac{4x^2y}{2z^2} \times \frac{6xz^3}{20y^4}$

ii) $\frac{p^2 - 10p + 21}{p - 7} \times \frac{p^2 + p - 12}{(p - 3)^2}$

iii) $\frac{5t^3}{4t - 8} \times \frac{6t - 12}{10t}$

Solution:

i. $\frac{4x^2y}{2z^2} \times \frac{6xz^3}{20y^4} = \frac{3x^3z}{5y^3}$

ii. $\frac{p^2 - 10p + 21}{p - 7} \times \frac{p^2 + p - 12}{(p - 3)^2}$

$$= \frac{(p - 7)(p - 3)}{(p - 7)} = \frac{(p + 4)(p - 3)}{(p - 3)^2} = (p + 4)$$

iii. $\frac{5t^3}{4t - 8} \times \frac{6t - 12}{10t}$

$$= \frac{5t^3}{4(t - 2)} \times \frac{6(t - 2)}{10t} = \frac{3t^2}{4}$$

3. Simplify: $\frac{x^3}{x - y} + \frac{y^3}{y - x}$

Solution:

$$\frac{x^3}{x - y} + \frac{y^3}{y - x} = \frac{x^3 - y^3}{x - y}$$

$$= \frac{(x^2 + xy + y^2)(x - y)}{(x - y)}$$

$$= x^2 + xy + y^2$$

4. Find the excluded values of the following expressions (if any).

MAY-22

i) $\frac{x + 10}{8x}$ ii) $\frac{7p + 2}{8p^2 + 13p + 5}$

Solution:

i. The expression $\frac{x + 10}{8x}$ is undefined when $8x = 0$ or $x = 0$.

When the excluded value is 0.

ii. The expression $\frac{7p + 2}{8p^2 + 13p + 5}$ is

undefined when $8p^2 + 13p + 5 = 0$ that is

$$(8p + 5)(p + 1) = 0 \quad p = -\frac{5}{8}, p = -1.$$

The excluded values are $-\frac{5}{8}$ and -1 .

5. Find the excluded values, if any of the following expressions.

i) $\frac{y}{y^2 - 25}$ ii) $\frac{t}{t^2 - 5t + 6}$
 iii) $\frac{x^2 + 6x + 8}{x^2 + x - 2}$ iv) $\frac{x^3 - 27}{x^3 + x^2 - 6x}$

Solution:

i. The expression $\frac{y}{y^2 - 25}$ is undefined

$$\text{when } y^2 - 5^2 = 0$$

$$y^2 - 5^2 = 0$$

$$(y + 5)(y - 5) = 0$$

$$y + 5 = 0, y - 5 = 0$$

$$y = -5, y = 5$$

Hence the excluded values are -5 and 5.

ii. The expression $\frac{t}{t^2 - 5t + 6}$ is undefined

$$\text{when } t^2 - 5t + 6 = 0$$

$$t^2 - 5t + 6 = 0$$

$$(t - 2)(t - 3) = 0$$

$$t - 2 = 0, t - 3 = 0$$

$$t = 2, t = 3$$

Hence the excluded values are 2 and 3.

iii. $\frac{x^2 + 6x + 8}{x^2 + x - 2} = \frac{(x+4)(x+2)}{(x+2)(x-1)} = \frac{x+4}{x-1}$

The expression $\frac{x+4}{x-1}$ is undefined when

$$x - 1 = 0. \text{ Hence the excluded value is 1.}$$

iv. $\frac{x^3 - 27}{x^3 + x^2 - 6x} = \frac{(x-3)(x^2 + 3x + 9)}{x(x^2 + x - 6)}$
 $= \frac{(x-3)(x^2 + 3x + 9)}{(x)(x+3)(x-2)}$

The expression $\frac{x^3 - 27}{x^3 + x^2 - 6x}$ is undefined

$$\text{when } x^3 + x^2 - 6x = 0$$

$$\Rightarrow (x)(x+3)(x-2) = 0$$

$$\Rightarrow x = 0 \text{ or } x = -3 \text{ or } x = 2$$

Hence the excluded values are 0, -3, 2

6. Find the square root of the following rational expression.

$$\frac{400x^4y^{12}z^{16}}{100x^8y^4z^4}$$

Solution:

$$\frac{400x^4y^{12}z^{16}}{100x^8y^4z^4} = \sqrt{\frac{4y^8z^{12}}{x^4}} = 2 \left| \frac{y^4z^6}{x^2} \right|$$

7. Find the square root of the following expressions

i) $256(x-a)^8(x-b)^4(x-c)^{16}(x-d)^{20}$

ii) $\frac{144a^8b^{12}c^{16}}{81f^{12}g^4h^{14}}$

Solution:

i. $\sqrt{(256(x-a)^8(x-b)^4(x-c)^{16}(x-d)^{20})}$
 $= 16 |(x-a)^4(x-b)^2(x-c)^8(x-d)^{10}|$

ii. $\sqrt{\frac{144a^8b^{12}c^{16}}{81f^{12}g^4h^{14}}} = \frac{4}{3} \left| \frac{a^4b^6c^8}{f^6g^2h^7} \right|$

8. Find the square root of the following rational expression.

$$\frac{121(a+b)^8(x+y)^8(b-c)^8}{81(b-c)^4(a-b)^{12}(b-c)^4}$$

Solution:

$$\frac{121(a+b)^8(x+y)^8(b-c)^8}{81(b-c)^4(a-b)^{12}(b-c)^4} =$$

$$\sqrt{\frac{121(a+b)^8(x+y)^8(b-c)^8}{81(b-c)^4(a-b)^{12}(b-c)^4}}$$

$$= \frac{11}{9} \left| \frac{(a+b)^4(x+y)^4}{(a-b)^6} \right|$$

9. Determine the quadratic equations, whose sum and product of roots are

(i) -9, 20 (ii) $\frac{5}{3}, 4$

SEP-21

Solution:

i. -9, 20

$$x^2 - [\alpha + \beta]x + \alpha\beta = 0$$

$$x^2 - [-9]x + 20 = 0 \Rightarrow x^2 + 9x + 20 = 0$$

ii. $\frac{5}{3}, 4$

Required Quadratic Equations

$$x^2 - (\text{Sum of the roots})x + \text{product of the roots} = 0$$

$$x^2 - \frac{5}{3}x + 4 = 0$$

Multiply 3 on both sides

$$3x^2 - 5x + 12 = 0$$

10. Find the sum and product of the roots for each of the following quadratic equations

(i) $x^2 + 3x - 28 = 0$ (ii) $x^2 + 3x = 0$

Solution:

i. $x^2 + 3x - 28 = 0$

$a = 1, b = 3, c = -28$

Sum of the roots $= \alpha + \beta = -\frac{b}{a} = -\frac{3}{1} = -3$

Product of the roots $= \alpha\beta = \frac{c}{a}$
 $= -\frac{28}{1} = -28$

ii. $x^2 + 3x = 0$

$a = 1, b = 3, c = 0$

Sum of the roots $= \alpha + \beta = -\frac{b}{a} = -\frac{3}{1} = -3$

Product of the roots $= \alpha\beta = \frac{c}{a} = \frac{0}{1} = 0$

11. In the matrix $A = \begin{pmatrix} 8 & 9 & 4 & 3 \\ -1 & \sqrt{7} & \frac{\sqrt{3}}{2} & 5 \\ 1 & 4 & 3 & 0 \\ 6 & 8 & -11 & 1 \end{pmatrix}$,

write

(i) The number of elements

(ii) The order of the matrix

(iii) Write the elements $a_{22}, a_{23}, a_{24}, a_{34}, a_{43}, a_{44}$.

Solution:

i) Number of elements $= 4 \times 4 = 16$

ii) Order of matrix $= 4 \times 4$

iii) $a_{22} = \sqrt{7}; a_{23} = \frac{\sqrt{3}}{2}; a_{24} = 5;$

$a_{34} = 0; a_{43} = -11; a_{44} = 1$

12. If a matrix has 18 elements, what are the possible orders it can have? What if it has 6 elements?

Solution:

Matrix having 18 elements 1×18 (or) 2×9
 (or) 3×6 (or) 6×3 (or) 9×2 (or) 18×1

Matrix having 6 elements 1×6 (or) 2×3 (or)
 3×2 (or) 6×1

13. Construct a 3×3 matrix whose elements are given by

(i) $a_{ij} = i - 2j$ (ii) $a_{ij} = \frac{(i+j)^3}{3}$

Solution:

i. $a_{ij} = |i - 2j|$

$$A = \begin{pmatrix} a_{11} & a_{12} & a_{13} \\ a_{21} & a_{22} & a_{23} \\ a_{31} & a_{32} & a_{33} \end{pmatrix}$$

$$= \begin{bmatrix} |1-2| & |1-4| & |1-6| \\ |2-2| & |2-4| & |2-6| \\ |3-2| & |3-4| & |3-6| \end{bmatrix}$$

$$= \begin{bmatrix} 1 & 3 & 5 \\ 0 & 2 & 4 \\ 1 & 1 & 3 \end{bmatrix}$$

ii. $a_{ij} = \frac{(i+j)^3}{3}$

$$= \begin{pmatrix} a_{11} & a_{12} & a_{13} \\ a_{21} & a_{22} & a_{23} \\ a_{31} & a_{32} & a_{33} \end{pmatrix}$$

$$= \begin{bmatrix} \frac{8}{3} & 9 & \frac{64}{3} \\ 9 & \frac{64}{3} & \frac{125}{3} \\ \frac{64}{3} & \frac{125}{3} & 72 \end{bmatrix}$$

14. Construct a 3×3 matrix whose elements are $a_{ij} = i^2 j^2$

Solution:

The general 3×3 matrix is given by

$$A = \begin{pmatrix} a_{11} & a_{12} & a_{13} \\ a_{21} & a_{22} & a_{23} \\ a_{31} & a_{32} & a_{33} \end{pmatrix}$$

$a_{11} = 1^2 \times 1^2 = 1 \times 1 = 1; a_{12} = 1^2 \times 2^2 = 1 \times 4 = 4;$
 $a_{13} = 1^2 \times 3^2 = 1 \times 9 = 9; a_{21} = 2^2 \times 1^2 = 4 \times 1 = 4;$
 $a_{22} = 2^2 \times 2^2 = 4 \times 4 = 16; a_{23} = 2^2 \times 3^2 = 4 \times 9 = 36$
 $a_{31} = 3^2 \times 1^2 = 9 \times 1 = 9; a_{32} = 3^2 \times 2^2 = 9 \times 4 = 36;$
 $a_{33} = 3^2 \times 3^2 = 9 \times 9 = 81$

Hence the required matrix is $A = \begin{pmatrix} 1 & 4 & 9 \\ 4 & 16 & 36 \\ 9 & 36 & 81 \end{pmatrix}$

15. If $A = \begin{pmatrix} 5 & 4 & 3 \\ 1 & -7 & 9 \\ 3 & 8 & 2 \end{pmatrix}$ then

find the transpose of A.

Solution:

$$A = \begin{pmatrix} 5 & 4 & 3 \\ 1 & -7 & 9 \\ 3 & 8 & 2 \end{pmatrix} \quad A^T = \begin{pmatrix} 5 & 1 & 3 \\ 4 & -7 & 8 \\ 3 & 9 & 2 \end{pmatrix}$$

16. If $A = \begin{pmatrix} \sqrt{7} & -3 \\ -\sqrt{5} & 2 \\ \sqrt{3} & -5 \end{pmatrix}$ then

find the transpose of $-A$.

SEP-20

Solution:

$$A = \begin{pmatrix} \sqrt{7} & -3 \\ -\sqrt{5} & 2 \\ \sqrt{3} & -5 \end{pmatrix} \quad -A = \begin{pmatrix} -\sqrt{7} & 3 \\ \sqrt{5} & -2 \\ -\sqrt{3} & 5 \end{pmatrix}$$

$$(-A)^T = \begin{pmatrix} -\sqrt{7} & \sqrt{5} & -\sqrt{3} \\ 3 & -2 & 5 \end{pmatrix}$$

17. If $A = \begin{pmatrix} 5 & 2 & 2 \\ -\sqrt{17} & 0.7 & \frac{5}{2} \\ 8 & 3 & 1 \end{pmatrix}$ then verify $(A^T)^T = A$

Solution:

$$A = \begin{pmatrix} 5 & 2 & 2 \\ -\sqrt{17} & 0.7 & \frac{5}{2} \\ 8 & 3 & 1 \end{pmatrix}$$

$$A^T = \begin{pmatrix} 5 & -\sqrt{17} & 8 \\ 2 & 0.7 & 3 \\ 2 & \frac{5}{2} & 1 \end{pmatrix}$$

$$(A^T)^T = \begin{pmatrix} 5 & 2 & 2 \\ -\sqrt{17} & 0.7 & \frac{5}{2} \\ 8 & 3 & 1 \end{pmatrix}$$

$$\therefore (A^T)^T = A$$

18. Find the values of x , y and z from the following equations

(i) $\begin{pmatrix} 12 & 3 \\ x & 5 \end{pmatrix} = \begin{pmatrix} y & z \\ 3 & 5 \end{pmatrix}$

(ii) $\begin{pmatrix} x+y & 2 \\ 5+z & xy \end{pmatrix} = \begin{pmatrix} 6 & 2 \\ 5 & 8 \end{pmatrix}$

(iii) $\begin{pmatrix} x+y+z \\ x+z \\ y+z \end{pmatrix} = \begin{pmatrix} 9 \\ 5 \\ 7 \end{pmatrix}$

Solution:

i. $\begin{pmatrix} 12 & 3 \\ x & 5 \end{pmatrix} = \begin{pmatrix} y & z \\ 3 & 5 \end{pmatrix}$

$$\Rightarrow 12 = y; 3 = z; x = 3$$

ii. $\begin{pmatrix} x+y & 2 \\ 5+z & xy \end{pmatrix} = \begin{pmatrix} 6 & 2 \\ 5 & 8 \end{pmatrix}$

$$\Rightarrow 5+z=5 \quad x+y=6;$$

$$z=5-5 \quad y=6-x;$$

$$z=0$$

$$xy=8$$

$$x(6-x)=8$$

$$6x-x^2-8=0$$

$$\Rightarrow x^2-6x+8=0$$

$$(x-2)(x-4)=0$$

$$x-2=0 \quad (\text{or}) \quad x-4=0$$

$$x=2 \quad (\text{or}) \quad x=4$$

$$\text{If } x=2 \text{ then } y = \frac{8}{x} = \frac{8}{2} = 4;$$

$$\text{If } x=4 \text{ then } y = \frac{8}{4} = 2$$

iii. $\begin{pmatrix} x+y+z \\ x+z \\ y+z \end{pmatrix} = \begin{pmatrix} 9 \\ 5 \\ 7 \end{pmatrix}$

$$x+y+z=9 \quad \dots (1)$$

$$x+z=5 \quad \dots (2)$$

$$y+z=7 \quad \dots (3)$$

Substitute (3) in (1)

$$x+7=9 \Rightarrow x=9-7=2$$

Substitute $x=2$ in (2)

$$2+z=5 \Rightarrow z=5-2=3$$

Substitute $z=3$ in (3)

$$y+3=7 \Rightarrow y=7-3 \Rightarrow y=4$$

19. If $A = \begin{pmatrix} 7 & 8 & 6 \\ 1 & 3 & 9 \\ -4 & 3 & -1 \end{pmatrix}$, $B = \begin{pmatrix} 4 & 11 & -3 \\ -1 & 2 & 4 \\ 7 & 5 & 0 \end{pmatrix}$

then Find $2A+B$.

Solution:

$$2A+B = 2 \begin{pmatrix} 7 & 8 & 6 \\ 1 & 3 & 9 \\ -4 & 3 & -1 \end{pmatrix} + \begin{pmatrix} 4 & 11 & -3 \\ -1 & 2 & 4 \\ 7 & 5 & 0 \end{pmatrix}$$

$$= \begin{pmatrix} 14 & 16 & 12 \\ 2 & 6 & 18 \\ -8 & 6 & -2 \end{pmatrix} + \begin{pmatrix} 4 & 11 & -3 \\ -1 & 2 & 4 \\ 7 & 5 & 0 \end{pmatrix}$$

$$= \begin{pmatrix} 14+4 & 16+11 & 12-3 \\ 2-1 & 6+2 & 18+4 \\ -8+7 & 6+5 & -2+0 \end{pmatrix}$$

$$= \begin{pmatrix} 18 & 27 & 9 \\ 1 & 8 & 22 \\ -1 & 11 & -2 \end{pmatrix}$$

$$20. \text{ If } A = \begin{pmatrix} 5 & 4 & -2 \\ 1 & 3 & \sqrt{2} \\ 2 & 4 & 4 \end{pmatrix}, B = \begin{pmatrix} -7 & 4 & -3 \\ 1 & 7 & 3 \\ 4 & 2 & 5 \end{pmatrix},$$

find $4A - 3B$.

Solution:

$$4A - 3B = 4 \begin{pmatrix} 5 & 4 & -2 \\ 1 & 3 & \sqrt{2} \\ 2 & 4 & 4 \end{pmatrix} - 3 \begin{pmatrix} -7 & 4 & -3 \\ 1 & 7 & 3 \\ 4 & 2 & 5 \end{pmatrix}$$

$$= \begin{pmatrix} 20 & 16 & -8 \\ 2 & 3 & 4\sqrt{2} \\ 4 & 36 & 16 \end{pmatrix} + \begin{pmatrix} 21 & -12 & 9 \\ -3 & -21 & -9 \\ -4 & -2 & -15 \end{pmatrix}$$

$$= \begin{pmatrix} 20+21 & 16-12 & -8+9 \\ 2-\frac{3}{4} & 3-\frac{21}{2} & 4\sqrt{2}-9 \\ 4-15 & 36+18 & 16-27 \end{pmatrix}$$

$$= \begin{pmatrix} 41 & 4 & 1 \\ \frac{5}{4} & -\frac{15}{2} & 4\sqrt{2}-9 \\ -11 & 54 & -11 \end{pmatrix}$$

$$21. \text{ If } A = \begin{pmatrix} 1 & 9 \\ 3 & 4 \\ 8 & -3 \end{pmatrix}, B = \begin{pmatrix} 5 & 7 \\ 3 & 3 \\ 1 & 0 \end{pmatrix} \text{ then verify}$$

that (i) $A+B = B+A$

(ii) $A+(-A) = (-A)+A = O$.

Solution:

i. $A+B = B+A$

L.H.S.

$$A+B = \begin{pmatrix} 1 & 9 \\ 3 & 4 \\ 8 & -3 \end{pmatrix} + \begin{pmatrix} 5 & 7 \\ 3 & 3 \\ 1 & 0 \end{pmatrix}$$

$$= \begin{pmatrix} 6 & 16 \\ 6 & 7 \\ 9 & -3 \end{pmatrix} \quad \dots (1)$$

R.H.S.

$$B+A = \begin{pmatrix} 5 & 7 \\ 3 & 3 \\ 1 & 0 \end{pmatrix} + \begin{pmatrix} 1 & 9 \\ 3 & 4 \\ 8 & -3 \end{pmatrix}$$

$$= \begin{pmatrix} 6 & 16 \\ 6 & 7 \\ 9 & -3 \end{pmatrix} \quad \dots (2)$$

$$(1), (2) \Rightarrow A+B = B+A$$

ii. $A+(-A) = (-A)+A = 0$

$$A+(-A) = \begin{pmatrix} 1 & 9 \\ 3 & 4 \\ 8 & -3 \end{pmatrix} + \begin{pmatrix} -1 & -9 \\ -3 & -4 \\ -8 & 3 \end{pmatrix}$$

$$= \begin{pmatrix} 0 & 0 \\ 0 & 0 \\ 0 & 0 \end{pmatrix} \quad \dots (1)$$

$$(-A)+A = \begin{pmatrix} -1 & -9 \\ -3 & -4 \\ -8 & 3 \end{pmatrix} + \begin{pmatrix} 1 & 9 \\ 3 & 4 \\ 8 & -3 \end{pmatrix}$$

$$= \begin{pmatrix} 0 & 0 \\ 0 & 0 \\ 0 & 0 \end{pmatrix} \quad \dots (2)$$

$$(1), (2) \Rightarrow A+(-A) = (-A)+A = 0$$

$$22. \text{ If } A = \begin{pmatrix} 0 & 4 & 9 \\ 8 & 3 & 7 \end{pmatrix}, B = \begin{pmatrix} 7 & 3 & 8 \\ 1 & 4 & 9 \end{pmatrix}$$

find the value of (i) $B - 5A$ (ii) $3A - 9B$

Solution:

$$A = \begin{pmatrix} 0 & 4 & 9 \\ 8 & 3 & 7 \end{pmatrix}, B = \begin{pmatrix} 7 & 3 & 8 \\ 1 & 4 & 9 \end{pmatrix}$$

i. $B - 5A$

$$= \begin{pmatrix} 7 & 3 & 8 \\ 1 & 4 & 9 \end{pmatrix} - 5 \begin{pmatrix} 0 & 4 & 9 \\ 8 & 3 & 7 \end{pmatrix}$$

$$= \begin{pmatrix} 7 & 3 & 8 \\ 1 & 4 & 9 \end{pmatrix} + \begin{pmatrix} 0 & -20 & -45 \\ -40 & -15 & -35 \end{pmatrix}$$

$$= \begin{pmatrix} 7 & -17 & -37 \\ -39 & -11 & -26 \end{pmatrix}$$

ii. $3A - 9B$

$$= 3 \begin{pmatrix} 0 & 4 & 9 \\ 8 & 3 & 7 \end{pmatrix} - 9 \begin{pmatrix} 7 & 3 & 8 \\ 1 & 4 & 9 \end{pmatrix}$$

$$= \begin{pmatrix} 0 & 12 & 27 \\ 24 & 9 & 21 \end{pmatrix} + \begin{pmatrix} -63 & -27 & -72 \\ -9 & -36 & -81 \end{pmatrix}$$

$$= \begin{pmatrix} -63 & -15 & -45 \\ 15 & -27 & -60 \end{pmatrix}$$

5 Marks

1. Find the square root of $64x^4 - 16x^3 + 17x^2 - 2x + 1$

Solution:

$$\begin{array}{r}
 8 \quad -1 \quad 1 \\
 8 \overline{) 64 \quad -16 \quad 17 \quad -2 \quad 1} \\
 \underline{(-) 64} \\
 16 \quad -1 \\
 \underline{(-) -16 \quad 17} \\
 16 \quad -2 \\
 \underline{(-) -16 \quad (-) 1} \\
 16 \quad -2 \quad 1 \\
 \underline{(-) 16 \quad (-) 2 \quad (-) 1} \\
 0
 \end{array}$$

Required Square root = $|8x^2 - x + 1|$

2. If $9x^4 + 12x^3 + 28x^2 + ax + b$ is a perfect square, find the values of a and b.

Solution:

$$\begin{array}{r}
 3 \quad 2 \quad 4 \\
 3 \overline{) 9 \quad 12 \quad 28 \quad a \quad b} \\
 \underline{(-) 9} \\
 6 \quad 2 \\
 \underline{(-) 12 \quad 28} \\
 6 \quad 4 \quad 4 \\
 \underline{(-) 24 \quad (-) 16 \quad (-) 16} \\
 a = 16, b = 16
 \end{array}$$

3. Find the square root of the following polynomials by division method

Solution:

- i. $x^4 - 12x^3 + 42x^2 - 36x + 9$

$$\begin{array}{r}
 1 \quad -6 \quad 3 \\
 1 \overline{) 1 \quad -12 \quad 42 \quad -36 \quad 9} \\
 \underline{(-) 1} \\
 2 \quad -6 \\
 \underline{(-) -12 \quad 42} \\
 2 \quad -12 \\
 \underline{(-) -12 \quad (-) 36} \\
 2 \quad -12 \quad 9 \\
 \underline{(-) 6 \quad (-) 36 \quad (-) 9} \\
 0
 \end{array}$$

Required Square root = $|x^2 - 6x + 3|$

- ii. $37x^2 - 28x^3 + 4x^4 + 42x + 9$

$$\begin{array}{r}
 2 \quad -7 \quad -3 \\
 2 \overline{) 4 \quad -28 \quad 37 \quad 42 \quad 9} \\
 \underline{(-) 4} \\
 4 \quad -7 \\
 \underline{(-) -28 \quad 37} \\
 \underline{(-) -28 \quad (-) 49}
 \end{array}$$

$$\begin{array}{r}
 4 \quad -14 \\
 -3 \overline{) \quad -12 \quad 42 \quad 9} \\
 \underline{(+)-12 \quad (-) 42 \quad (-) 9} \\
 0
 \end{array}$$

Required Square root = $|2x^2 - 7x - 3|$

- iii. $16x^4 + 8x^2 + 1$

$$\begin{array}{r}
 4 \quad 0 \quad 1 \\
 4 \overline{) 16 \quad 0 \quad 8 \quad 0 \quad 1} \\
 \underline{(-) 16} \\
 8 \quad 0 \\
 \underline{0 \quad 8} \\
 8 \quad 0 \quad 1 \\
 \underline{(-) 8 \quad (-) 0 \quad (-) 1} \\
 0
 \end{array}$$

Required Square root = $|4x^2 + 1|$

- iv. $121x^4 - 198x^3 - 183x^2 + 216x + 144$

$$\begin{array}{r}
 11 \quad -9 \quad -12 \\
 11 \overline{) 121 \quad -198 \quad -183 \quad 216} \\
 \underline{144} \\
 \underline{(-) 121} \\
 -198 \quad -183 \\
 \underline{(+)-198 \quad (-) 81} \\
 -264 \quad 216 \quad 144 \\
 \underline{(+)-264 \quad (-) 216 \quad (-) 144} \\
 0
 \end{array}$$

Required Square root = $|11x^2 - 9x - 12|$

4. Find the values of a and b if the following polynomials are perfect squares

- i. $4x^4 - 12x^3 + 37x^2 + bx + a$

Solution:

$$\begin{array}{r}
 2 \quad -3 \quad 7 \\
 2 \overline{) 4 \quad -12 \quad 37 \quad b \quad a} \\
 \underline{(-) 4} \\
 4 \quad -3 \\
 \underline{(-) -12 \quad 37} \\
 4 \quad -6 \quad 7 \\
 \underline{(-) -12 \quad (-) 9} \\
 28 \quad b \quad a \\
 \underline{(-) 28 \quad (+)-42 \quad (-) 49} \\
 a = 49, b = -42
 \end{array}$$

ii. $ax^4 + bx^3 + 361x^2 + 220x + 100$

Solution:

$$\begin{array}{r}
 10 \quad 11 \quad 12 \\
 10 \quad \begin{array}{|l} 100 \quad 220 \quad 361 \quad b \quad a \\ (-)100 \end{array} \\
 \hline
 20 \quad 11 \quad \begin{array}{|l} 220 \quad 361 \\ (-) 220 \quad (-)121 \end{array} \\
 \hline
 20 \quad 22 \quad 12 \quad \begin{array}{|l} 240 \quad b \quad a \\ (-) 240 \quad (-)264 \quad (-)144 \end{array} \\
 \hline
 a = 144, b = 264
 \end{array}$$

5. Find the values of m and n if the following polynomials are perfect squares

i. $36x^4 - 60x^3 + 61x^2 - mx + n$

MAY-22

Solution:

$$\begin{array}{r}
 6 \quad -5 \quad 3 \\
 6 \quad \begin{array}{|l} 36 \quad -60 \quad 61 \quad -m \quad n \\ (-) 36 \end{array} \\
 \hline
 12 \quad -5 \quad \begin{array}{|l} -60 \quad 61 \\ (+) -60 \quad (-)25 \end{array} \\
 \hline
 12 \quad -10 \quad \begin{array}{|l} 36 \quad -m \quad n \\ (-) 36 \quad (+) -30 \quad (-) 9 \end{array} \\
 \hline
 3 \quad \begin{array}{|l} -m = -30, m = 30 \\ n = 9 \end{array}
 \end{array}$$

ii. $x^4 - 8x^3 + mx^2 + nx + 16$

Solution:

$$\begin{array}{r}
 1 \quad -4 \quad 4 \\
 1 \quad \begin{array}{|l} 1 \quad -8 \quad m \quad n \quad 16 \\ (-) 1 \end{array} \\
 \hline
 2 \quad -4 \quad \begin{array}{|l} -8 \quad m \\ (+) -8 \quad (-)16 \end{array} \\
 \hline
 2 \quad -8 \quad 4 \quad \begin{array}{|l} m-16 \quad n \quad 16 \\ (-) 8 \quad (+) -32 \quad (-) 16 \end{array} \\
 \hline
 0
 \end{array}$$

$$\frac{m-16}{2} = 4$$

$$m - 16 = 8, n = -32$$

$$m = 8 + 16$$

$$m = 24$$

6. If $A = \begin{pmatrix} 4 & 3 & 1 \\ 2 & 3 & -8 \\ 1 & 0 & -4 \end{pmatrix}$, $B = \begin{pmatrix} 2 & 3 & 4 \\ 1 & 9 & 2 \\ -7 & 1 & -1 \end{pmatrix}$

and $C = \begin{pmatrix} 8 & 3 & 4 \\ 1 & -2 & 3 \\ 2 & 4 & -1 \end{pmatrix}$ then verify that

$$A + (B + C) = (A + B) + C.$$

Solution:

$$A + (B + C) = \begin{pmatrix} 4 & 3 & 1 \\ 2 & 3 & -8 \\ 1 & 0 & -4 \end{pmatrix}$$

$$+ \left(\begin{pmatrix} 2 & 3 & 4 \\ 1 & 9 & 2 \\ -7 & 1 & -1 \end{pmatrix} + \begin{pmatrix} 8 & 3 & 4 \\ 1 & -2 & 3 \\ 2 & 4 & -1 \end{pmatrix} \right)$$

$$= \begin{pmatrix} 4 & 3 & 1 \\ 2 & 3 & -8 \\ 1 & 0 & -4 \end{pmatrix} + \begin{pmatrix} 10 & 6 & 8 \\ 2 & 7 & 5 \\ -5 & 5 & -2 \end{pmatrix}$$

$$= \begin{pmatrix} 14 & 9 & 9 \\ 4 & 10 & -3 \\ -4 & 5 & -6 \end{pmatrix} \quad \dots (1)$$

$$(A + B) + C$$

$$= \left(\begin{pmatrix} 4 & 3 & 1 \\ 2 & 3 & -8 \\ 1 & 0 & -4 \end{pmatrix} + \begin{pmatrix} 2 & 3 & 4 \\ 1 & 9 & 2 \\ -7 & 1 & -1 \end{pmatrix} \right)$$

$$+ \begin{pmatrix} 8 & 3 & 4 \\ 1 & -2 & 3 \\ 2 & 4 & -1 \end{pmatrix}$$

$$= \begin{pmatrix} 14 & 9 & 9 \\ 4 & 10 & -3 \\ -4 & 5 & -6 \end{pmatrix} \quad \dots (2)$$

From (1) & (2) LHS = RHS

7. If $A = \begin{pmatrix} 1 & 1 \\ -1 & 3 \end{pmatrix}$, $B = \begin{pmatrix} 1 & 2 \\ -4 & 2 \end{pmatrix}$, $C = \begin{pmatrix} -7 & 6 \\ 3 & 2 \end{pmatrix}$

verify that $A(B + C) = AB + AC$.

Solution:

$$B + C = \begin{pmatrix} 1 & 2 \\ -4 & 2 \end{pmatrix} + \begin{pmatrix} -7 & 6 \\ 3 & 2 \end{pmatrix}$$

$$= \begin{pmatrix} 1-7 & 2+6 \\ -4+3 & 2+2 \end{pmatrix} = \begin{pmatrix} -6 & 8 \\ -1 & 4 \end{pmatrix}$$

$$\text{LHS} = A(B + C)$$

$$= \begin{pmatrix} 1 & 1 \\ -1 & 3 \end{pmatrix} \begin{pmatrix} -6 & 8 \\ -1 & 4 \end{pmatrix}$$

$$= \begin{pmatrix} -6-1 & 8+4 \\ 6-3 & -8+12 \end{pmatrix} = \begin{pmatrix} -7 & 12 \\ 3 & 4 \end{pmatrix}$$

$$AB = \begin{pmatrix} 1 & 1 \\ -1 & 3 \end{pmatrix} \begin{pmatrix} 1 & 2 \\ -4 & 2 \end{pmatrix}$$

$$= \begin{pmatrix} 1-4 & 2+2 \\ -1-12 & -2+6 \end{pmatrix} = \begin{pmatrix} -3 & 4 \\ -13 & 4 \end{pmatrix}$$

$$AC = \begin{pmatrix} 1 & 1 \\ -1 & 3 \end{pmatrix} \begin{pmatrix} -7 & 6 \\ 3 & 2 \end{pmatrix}$$

$$= \begin{pmatrix} -7+3 & 6+2 \\ 7+9 & -6+6 \end{pmatrix} = \begin{pmatrix} -4 & 8 \\ 16 & 0 \end{pmatrix}$$

$$\text{RHS} = AB + AC$$

$$= \begin{pmatrix} -3 & 4 \\ -13 & 4 \end{pmatrix} + \begin{pmatrix} -4 & 8 \\ 16 & 0 \end{pmatrix}$$

$$= \begin{pmatrix} -3-4 & 4+8 \\ -13+16 & 4+0 \end{pmatrix} = \begin{pmatrix} -7 & 12 \\ 3 & 4 \end{pmatrix}$$

$$\therefore \text{LHS} = \text{RHS}$$

8. If $A = \begin{pmatrix} 1 & 2 & 1 \\ 2 & -1 & 1 \end{pmatrix}$ and $B = \begin{pmatrix} 2 & -1 \\ -1 & 4 \\ 0 & 2 \end{pmatrix}$

show that $(AB)^T = B^T A^T$

SEP-20

Solution:

$$AB = \begin{pmatrix} 1 & 2 & 1 \\ 2 & -1 & 1 \end{pmatrix} \begin{pmatrix} 2 & -1 \\ -1 & 4 \\ 0 & 2 \end{pmatrix}$$

$$= \begin{pmatrix} 2-2+0 & -1+8+2 \\ 4+1+0 & -2-4+2 \end{pmatrix} = \begin{pmatrix} 0 & 9 \\ 5 & -4 \end{pmatrix}$$

$$(AB)^T = \begin{pmatrix} 0 & 5 \\ 9 & -4 \end{pmatrix}$$

$$B^T = \begin{pmatrix} 2 & -1 & 0 \\ -1 & 4 & 2 \end{pmatrix} \quad A^T = \begin{pmatrix} 1 & 2 \\ 2 & -1 \\ 1 & 1 \end{pmatrix}$$

$$B^T A^T = \begin{pmatrix} 2 & -1 & 0 \\ -1 & 4 & 2 \end{pmatrix} \begin{pmatrix} 1 & 2 \\ 2 & -1 \\ 1 & 1 \end{pmatrix}$$

$$B^T A^T = \begin{pmatrix} 2-2+0 & 4+1+0 \\ -1+8+2 & -2-4+2 \end{pmatrix} = \begin{pmatrix} 0 & 9 \\ 5 & -4 \end{pmatrix}$$

$$\therefore \text{LHS} = \text{RHS}$$

9. Given that $A = \begin{pmatrix} 1 & 3 \\ 5 & -1 \end{pmatrix}$,

$$B = \begin{pmatrix} 1 & -1 & 2 \\ 3 & 5 & 2 \end{pmatrix}, C = \begin{pmatrix} 1 & 3 & 2 \\ -4 & 1 & 3 \end{pmatrix}$$

verify that $A(B+C) = AB + AC$.

Solution:

$$A = \begin{pmatrix} 1 & 3 \\ 5 & -1 \end{pmatrix}, B = \begin{pmatrix} 1 & -1 & 2 \\ 3 & 5 & 2 \end{pmatrix}, C = \begin{pmatrix} 1 & 3 & 2 \\ -4 & 1 & 3 \end{pmatrix}$$

To verify that $A(B+C) = AB + AC$

LHS

$$B + C = \begin{pmatrix} 1 & -1 & 2 \\ 3 & 5 & 2 \end{pmatrix} + \begin{pmatrix} 1 & 3 & 2 \\ -4 & 1 & 3 \end{pmatrix}$$

$$= \begin{pmatrix} 2 & 2 & 4 \\ -1 & 6 & 5 \end{pmatrix}$$

$$A(B+C) = \begin{pmatrix} 1 & 3 \\ 5 & -1 \end{pmatrix} \times \begin{pmatrix} 2 & 2 & 4 \\ -1 & 6 & 5 \end{pmatrix}$$

$$= \begin{pmatrix} 2-3 & 2+18 & 4+15 \\ 10+1 & 10-6 & 20-5 \end{pmatrix}$$

$$= \begin{pmatrix} -1 & 20 & 19 \\ 11 & 4 & 15 \end{pmatrix} \quad \dots(1)$$

$$AB = \begin{pmatrix} 1 & 3 \\ 5 & -1 \end{pmatrix} \times \begin{pmatrix} 1 & -1 & 2 \\ 3 & 5 & 2 \end{pmatrix}$$

$$= \begin{pmatrix} 1+9 & -1+15 & 2+6 \\ 5-3 & -5-5 & 10-2 \end{pmatrix}$$

$$= \begin{pmatrix} 10 & 14 & 8 \\ 2 & -10 & 8 \end{pmatrix}$$

$$AB + AC = \begin{pmatrix} -1 & 20 & 19 \\ 11 & 4 & 15 \end{pmatrix} \quad \dots(2)$$

$$(1), (2) \Rightarrow A(B+C) = AB + AC.$$

10. If $A = \begin{pmatrix} 5 & 2 & 9 \\ 1 & 2 & 8 \end{pmatrix}$, $B = \begin{pmatrix} 1 & 7 \\ 1 & 2 \\ 5 & -1 \end{pmatrix}$

verify that $(AB)^T = B^T A^T$

Solution:

$$A = \begin{pmatrix} 5 & 2 & 9 \\ 1 & 2 & 8 \end{pmatrix}, B = \begin{pmatrix} 1 & 7 \\ 1 & 2 \\ 5 & -1 \end{pmatrix}$$

$$AB = \begin{pmatrix} 5+2+45 & 35+4-9 \\ 1+2+40 & 7+4-8 \end{pmatrix} = \begin{pmatrix} 52 & 30 \\ 43 & 3 \end{pmatrix}$$

$$(AB)^T = \begin{pmatrix} 52 & 43 \\ 30 & 3 \end{pmatrix}$$

$$B^T = \begin{pmatrix} 1 & 1 & 5 \\ 7 & 2 & -1 \end{pmatrix} \quad A^T = \begin{pmatrix} 5 & 1 \\ 2 & 2 \\ 9 & 8 \end{pmatrix}$$

$$B^T A^T = \begin{pmatrix} 1 & 1 & 5 \\ 7 & 2 & -1 \end{pmatrix} \times \begin{pmatrix} 5 & 1 \\ 2 & 2 \\ 9 & 8 \end{pmatrix}$$

$$= \begin{pmatrix} 5+2+45 & 1+2+40 \\ 35+4-9 & 7+4-8 \end{pmatrix}$$

$$= \begin{pmatrix} 52 & 43 \\ 30 & 3 \end{pmatrix}$$

$$(1), (2) \Rightarrow (AB)^T = B^T A^T$$

11. If $A = \begin{pmatrix} 3 & 1 \\ -1 & 2 \end{pmatrix}$ show that $A^2 - 5A + 7I_2 = 0$

Solution:

$$A^2 = \begin{pmatrix} 3 & 1 \\ -1 & 2 \end{pmatrix} \begin{pmatrix} 3 & 1 \\ -1 & 2 \end{pmatrix}$$

$$= \begin{pmatrix} 9-1 & 3+2 \\ -3-2 & -1+4 \end{pmatrix} = \begin{pmatrix} 8 & 5 \\ -5 & 3 \end{pmatrix}$$

$$A^2 - 5A + 7I_2$$

$$= \begin{pmatrix} 8 & 5 \\ -5 & 3 \end{pmatrix} - \begin{pmatrix} -15 & -5 \\ 5 & -10 \end{pmatrix} + \begin{pmatrix} 7 & 0 \\ 0 & 7 \end{pmatrix}$$

$$= \begin{pmatrix} 8-15+7 & 5-5+0 \\ -5+5+0 & 3-10+7 \end{pmatrix} = \begin{pmatrix} 0 & 0 \\ 0 & 0 \end{pmatrix}$$

Hence, $A^2 - 5A + 7I_2 = 0$

4. Geometry

2 Marks

1. If ΔABC is similar to ΔDEF such that $BC = 3$ cm, $EF = 4$ cm and area of $\Delta ABC = 54$ cm². Find the area of ΔDEF .

Solution:

Since the ratio of area of two similar triangles is equal to the ratio of the squares of any two corresponding sides, we have

$$\frac{\text{Area}(\Delta ABC)}{\text{Area}(\Delta DEF)} = \frac{BC^2}{EF^2}$$

gives $\frac{54}{\text{Area}(\Delta DEF)} = \frac{3^2}{4^2}$

$$\text{Area}(\Delta DEF) = \frac{16 \times 54}{9} = 96 \text{ cm}^2$$

2. Check whether the which triangles are similar and find the value of x .

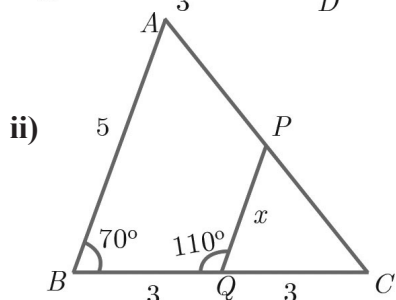
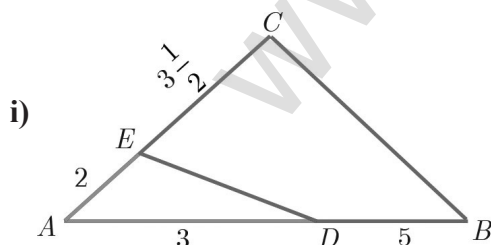

Solution:

- i. From the figure, in ΔABC and ΔADE

$$\frac{AC}{AE} = \frac{3\frac{1}{2}+2}{2} = \frac{7+2}{2} = \frac{7+4}{2}$$

$$= \frac{11}{2} \times \frac{1}{2} = \frac{11}{4} \quad \dots (1)$$

$$\frac{AB}{AD} = \frac{3+5}{3} = \frac{8}{3} \quad \dots (2)$$

From (1), (2) $\Rightarrow \frac{AC}{AE} \neq \frac{AB}{AD}$

$\therefore \Delta ABC$ and ΔADE are not similar

- ii. From the figure, in ΔABC and ΔPQC

$$\angle ABC = \angle PQC = 70^\circ \quad \dots (1)$$

(Corresponding angles are equal)

$$\angle C = \angle C \text{ (Common Angles)} \quad \dots (2)$$

$\therefore \angle A = \angle QPC$ (\because AAA criterion)

Hence, ΔABC and ΔPQC are similar triangles

Then, $\frac{AB}{PQ} = \frac{BC}{QC} \Rightarrow \frac{5}{x} = \frac{6}{3} = 2$

$$\therefore x = \frac{5}{2} = 2.5$$

3. If $\Delta ABC \sim \Delta DEF$ such that area of ΔABC is 9 cm² and the area of ΔDEF is 16 cm² and $BC = 2.1$ cm. Find the length of EF .

Solution:

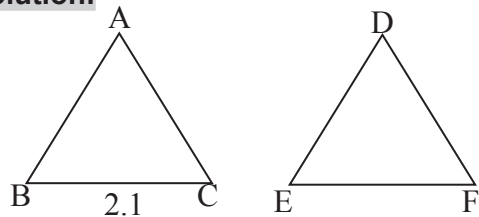

Given $\Delta ABC \sim \Delta DEF$

$$\frac{\text{Area of } (\Delta ABC)}{\text{Area of } (\Delta DEF)} = \frac{BC^2}{EF^2}$$

$$= \frac{AB^2}{DE^2} = \frac{AC^2}{DF^2}$$

$$\Rightarrow \frac{9}{16} = \frac{(2.1)^2}{EF^2}$$

$$\Rightarrow EF^2 = (2.1)^2 \times \frac{16}{9}$$

$$\Rightarrow EF = 2.1 \times \frac{4}{3} = 2.8 \text{ cm}$$

4. D and E are respectively the points on the sides AB and AC of a $\triangle ABC$ such that $AB = 5.6$ cm, $AD = 1.4$ cm, $AC = 7.2$ cm and $AE = 1.8$ cm, show that $DE \parallel BC$.

Solution:

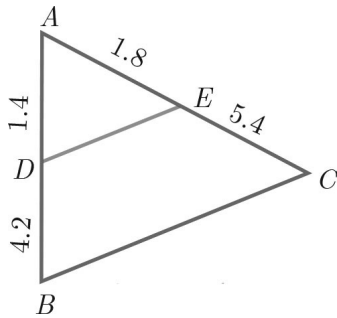

$AB = 5.6$ cm, $AD = 1.4$ cm, $AC = 7.2$ cm and $AE = 1.8$ cm

$BD = AB - AD = 5.6 - 1.4 = 4.2$ cm and

$EC = AC - AE = 7.2 - 1.8 = 5.4$ cm

$$\frac{AD}{DB} = \frac{1.4}{4.2} = \frac{1}{3} \quad \text{and} \quad \frac{AE}{EC} = \frac{1.8}{5.4} = \frac{1}{3}$$

$$\frac{AD}{DB} = \frac{AE}{EC}$$

Therefore, by converse of Basic Proportionality Theorem, we have DE is parallel to BC .

Hence Proved.

5. In the Figure, AD is the bisector of $\angle A$. If $BD = 4$ cm, $DC = 3$ cm and $AB = 6$ cm, find AC .

MAY-22

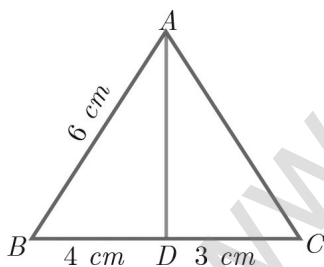

Solution:

In $\triangle ABC$, AD is the bisector of $\angle A$.

Therefore by Angle Bisector Theorem

$$\frac{BD}{DC} = \frac{AB}{AC}$$

$$\frac{4}{3} = \frac{6}{AC} \quad \text{gives} \quad 4AC = 18$$

$$\text{Hence} \quad AC = \frac{9}{2} = 4.5 \text{ cm}$$

6. In the Figure, AD is the bisector of $\angle BAC$, if $AB = 10$ cm, $AC = 14$ cm and $BC = 6$ cm. Find BD and DC .

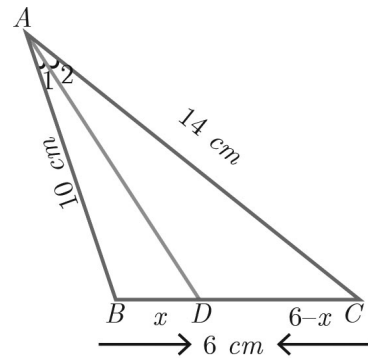

Solution:

AD is the bisector of $\angle BAC$

$AB = 10$ cm, $AC = 14$ cm, $BC = 6$ cm

By Angle Bisector Theorem

$$\frac{BD}{DC} = \frac{AB}{AC}$$

$$\frac{x}{6-x} = \frac{10}{14}$$

$$\frac{x}{6-x} = \frac{5}{7}$$

$$7x = 30 - 5x$$

$$12x = 30$$

$$x = \frac{30}{12} = 2.5 \text{ cm}$$

$$\therefore BD = 2.5 \text{ cm} \quad DC = 3.5 \text{ cm}$$

7. In $\triangle ABC$, D and E are points on the sides AB and AC respectively such that $DE \parallel BC$

SEP-21

(i) If $\frac{AD}{DB} = \frac{3}{4}$ and $AC = 15$ cm find AE .

(ii) If $AD = 8x - 7$, $DB = 5x - 3$, $AE = 4x - 3$ and $EC = 3x - 1$, find the value of x .

Solution:

i. If $\frac{AD}{DB} = \frac{3}{4}$, $AC = 15$ cm, $AE = x$,

$$EC = 15 - x$$

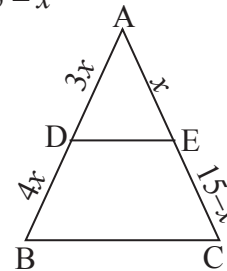

$DE \parallel BC$ then by basic proportionality theorem.

$$\frac{AD}{DB} = \frac{AE}{EC}$$

$$\Rightarrow \frac{3}{4} = \frac{x}{15-x}$$

$$\begin{aligned}
 3(15-x) &= 4x \\
 45 - 3x &= 4x \\
 45 &= 7x \\
 x &= \frac{45}{7} = 6.43 \text{ cm}
 \end{aligned}$$

- ii. Given $AD = 8x - 7$, $DB = 5x - 3$,
 $AE = 4x - 3$ and $EC = 3x - 1$
 By basic proportionality theorem

$$\begin{aligned}
 \frac{AD}{DB} &= \frac{AE}{EC} \\
 \Rightarrow \frac{8x-7}{5x-3} &= \frac{4x-3}{3x-1} \\
 \Rightarrow (8x-7)(3x-1) &= (5x-3)(4x-3) \\
 \Rightarrow 24x^2 - 29x + 7 &= 20x^2 - 27x + 9 \\
 24x^2 - 20x^2 - 29x + 27x + 7 - 9 &= 0 \\
 \Rightarrow 4x^2 - 2x - 2 &= 0 \\
 \Rightarrow 2x^2 - x - 1 &= 0 \\
 (2x+1)(x-1) &= 0 \\
 x = 1, x = -\frac{1}{2} & \text{ (Not Admissible).} \\
 \therefore x &= 1
 \end{aligned}$$

8. In $\triangle ABC$, D and E are points on the sides AB and AC respectively. For each of the following cases show that $DE \parallel BC$.

- (i) $AB = 12 \text{ cm}$, $AD = 8 \text{ cm}$, $AE = 12 \text{ cm}$ and $AC = 18 \text{ cm}$.
 (ii) $AB = 5.6 \text{ cm}$, $AD = 1.4 \text{ cm}$, $AC = 7.2 \text{ cm}$ and $AE = 1.8 \text{ cm}$.

Solution:

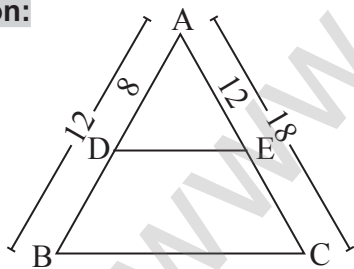

- i. $AB = 12 \text{ cm}$, $AD = 8 \text{ cm}$, $AE = 12 \text{ cm}$ and $AC = 18 \text{ cm}$

$$\frac{AD}{AB} = \frac{8}{12} = \frac{2}{3} \quad \dots (1)$$

$$\frac{AE}{AC} = \frac{12}{18} = \frac{2}{3} \quad \dots (2)$$

$$\text{From (1) \& (2) } \Rightarrow \frac{AD}{AB} = \frac{AE}{AC}$$

$\therefore DE \parallel BC$

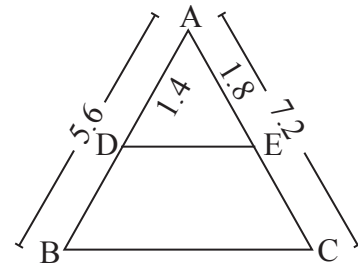

- ii. $AB = 5.6 \text{ cm}$, $AD = 1.4 \text{ cm}$, $AC = 7.2 \text{ cm}$ and $AE = 1.8 \text{ cm}$

$$\frac{AD}{AB} = \frac{1.4}{5.6} = \frac{1}{4} \quad \dots (1)$$

$$\frac{AE}{AC} = \frac{1.8}{7.2} = \frac{1}{4} \quad \dots (2)$$

$$(1), (2) \Rightarrow \frac{AD}{AB} = \frac{AE}{AC}$$

$\therefore DE \parallel BC$

9. Check whether AD is bisector of $\angle A$ of $\triangle ABC$ in each of the following

- (i) $AB = 5 \text{ cm}$, $AC = 10 \text{ cm}$, $BD = 1.5 \text{ cm}$ and $CD = 3.5 \text{ cm}$. SEP-20

- (ii) $AB = 4 \text{ cm}$, $AC = 6 \text{ cm}$, $BD = 1.6 \text{ cm}$ and $CD = 2.4 \text{ cm}$.

Solution:

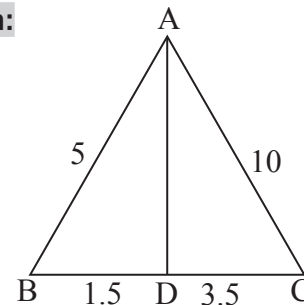

- i. $AB = 5 \text{ cm}$, $AC = 10 \text{ cm}$, $BD = 1.5 \text{ cm}$ and $CD = 3.5 \text{ cm}$

$$\frac{AB}{AC} = \frac{5}{10} = \frac{1}{2} \quad \dots (1)$$

$$\frac{BD}{CD} = \frac{1.5}{3.5} = \frac{3}{7} \quad \dots (2)$$

$$(1), (2) \Rightarrow \frac{AB}{AC} \neq \frac{BD}{CD} \quad (\because \text{By ABT})$$

AD is not a bisector of $\angle A$ in $\triangle ABC$

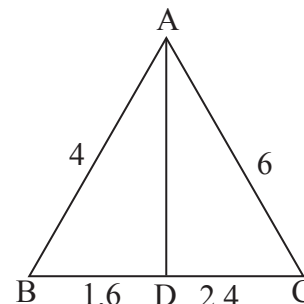

- ii. $AB = 4$ cm, $AC = 6$ cm, $BD = 1.6$ cm and $CD = 2.4$ cm

$$\frac{AB}{AC} = \frac{4}{6} = \frac{2}{3} \quad \dots (1)$$

$$\frac{BD}{CD} = \frac{1.6}{2.4} = \frac{2}{3} \quad \dots (2)$$

$$(1), (2) \Rightarrow \frac{AB}{AC} = \frac{BD}{CD} \quad (\because \text{By ABT})$$

AD is a bisector of $\angle A$ in $\triangle ABC$

5 Marks

1. State and Prove Basic Proportionality Theorem (BPT) or Thales Theorem. **MAY-22**

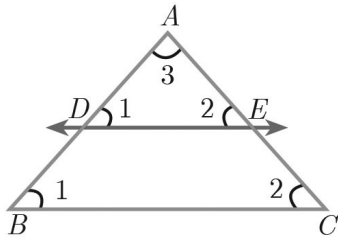

Statement:

A straight line drawn parallel to a side of triangle intersecting the other two sides, divides the sides in the same ratio.

Proof

Given:

In $\triangle ABC$, D is a point on AB and E is a point on AC

To Prove:

$$\frac{AD}{DB} = \frac{AE}{EC}$$

Construction: Draw a line $DE \parallel BC$

No.	Statement	Reason
1.	$\angle ABC = \angle ADE$ → 1	Corresponding angles are equal because $DE \parallel BC$
2.	$\angle ACB = \angle AED$ → 2	Corresponding angles are equal because $DE \parallel BC$
3.	$\angle DAE = \angle BAC$ → 3	Both triangles have a common angle.
	$\triangle ABC \sim \triangle ADE$	By AAA similarity
	$\frac{AB}{AD} = \frac{AC}{AE}$	Corresponding sides are proportional
	$\frac{AD + DB}{AD} = \frac{AE + EC}{AE}$	Split AB and AC using the points D and E

	$1 + \frac{DB}{AD} = 1 + \frac{EC}{AE}$	On Simplification
	$\frac{DB}{AD} = \frac{EC}{AE}$	Cancelling 1 on both sides
	$\frac{AD}{DB} = \frac{AE}{EC}$	Taking reciprocals
	Hence Proved	

2. State and Prove Angle Bisector Theorem.

Statement:

SEP-20

The internal bisector of an angle of a triangle divides the opposite side internally in the ratio of the corresponding sides containing the angle

Proof

Given:

In $\triangle ABC$, AD is the internal bisector

To Prove:

$$\frac{AB}{AC} = \frac{BD}{CD}$$

Construction:

Draw a line through C parallel to AB .

Extend AD to meet line through C at E .

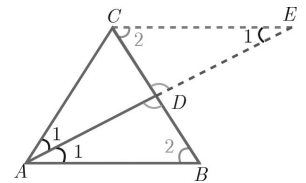

No.	Statement	Reason
1.	$\angle AEC = \angle BAE$ $= \angle 1$	Two parallel lines cut by a transversal make alternate angles equal.
2.	$\triangle ACE$ is isosceles $AC = CE$ (1)	In $\triangle ACE$ $\angle CAE = \angle CEA$.
3.	$\triangle ABD \sim \triangle ECD$ $\frac{AB}{CE} = \frac{BD}{CD}$	By AA Similarity
4.	$\frac{AB}{AC} = \frac{BD}{CD}$	From (1) $AC = CE$. Hence Proved.

3. State and Prove Pythagoras Theorem.

Statement:

In a right angle triangle, the square on the hypotenuse is equal to the sum of the squares on the other two sides.

Proof**Given:**

In $\triangle ABC$, $\angle A = 90^\circ$

To Prove:

$$AB^2 + AC^2 = BC^2$$

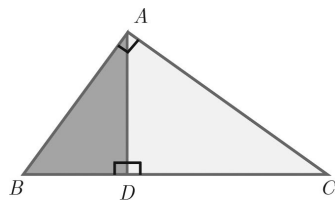

Construction: Draw $AD \perp BC$

No.	Statement	Reason
1.	Compare $\triangle ABC$ and $\triangle ABD$ $\angle B$ is common $\angle BAC = \angle BDA = 90^\circ$ Therefore, $\triangle ABC \sim \triangle ABD$ $\frac{AB}{BD} = \frac{BC}{AB}$ $AB^2 = BC \times BD$ (1)	Given $\angle BAC = 90^\circ$ and by construction $\angle BDA = 90^\circ$ By AA similarity
2.	Compare $\triangle ABC$ and $\triangle ADC$ $\angle C$ is common $\angle BAC = \angle ADC = 90^\circ$ Therefore, $\triangle ABC \sim \triangle ADC$ $\frac{BC}{AC} = \frac{AC}{DC}$ $AC^2 = BC \times DC$... (2)	Given $\angle BAC = 90^\circ$ and by construction $\angle CDA = 90^\circ$ By AA similarity

Adding (1) and (2) we get

$$AB^2 + AC^2 = BC \times BD + BC \times DC$$

$$= BC (BD + DC)$$

$$AB^2 + AC^2 = BC \times BC = BC^2$$

Hence the theorem is proved.

4. Show that in a triangle, the medians are concurrent.

SEP-21

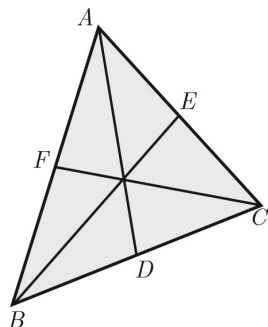
Solution:

Medians are line segments joining each vertex to the midpoint of the corresponding opposite sides.

Thus medians are the cevians where D, E, F are midpoints of BC, CA and AB respectively. Since D is midpoint of BC,

$$BD = DC. \text{ So } \frac{BD}{DC} = 1 \quad \dots (1)$$

Since E is midpoint of CA,

$$CE = EA. \text{ So } \frac{CE}{EA} = 1 \quad \dots (2)$$

Since F is midpoint of AB,

$$AF = FB. \text{ So } \frac{AF}{FB} = 1 \quad \dots (3)$$

Thus, multiplying (1), (2), (3) we get

$$\frac{BD}{DC} \times \frac{CE}{EA} \times \frac{AF}{FB}$$

$$= 1 \times 1 \times 1 = 1$$

And so, Ceva's theorem is satisfied.

Hence the Medians are concurrent.

5. Coordinate Geometry

2 Marks

1. Find the area of the triangle whose vertices are $(-3, 5)$, $(5, 6)$ and $(5, -2)$

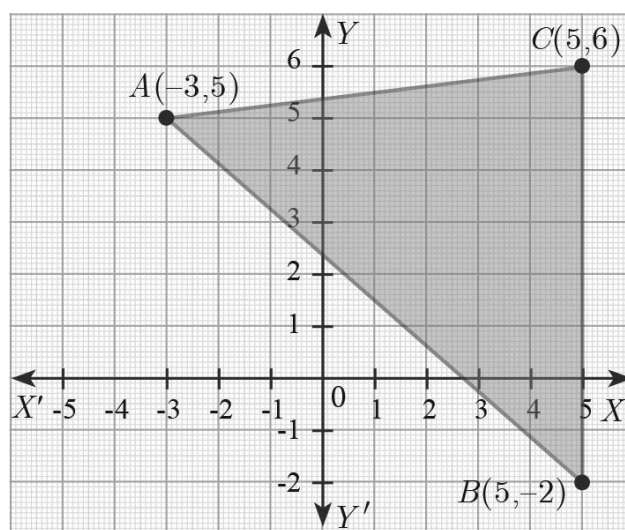
Solution:

$$A(-3, 5), \quad B(5, -2), \quad C(5, 6)$$

$$\downarrow$$

$$x_1y_1$$

$$\downarrow$$

$$x_2y_2$$

$$\downarrow$$

$$x_3y_3$$

$$\begin{aligned} \text{Area of } \Delta &= \frac{1}{2} \begin{vmatrix} x_1 & y_1 \\ x_2 & y_2 \\ x_3 & y_3 \end{vmatrix} = \frac{1}{2} \begin{vmatrix} -3 & 5 \\ 5 & -2 \\ 5 & 6 \end{vmatrix} \\ &= \frac{1}{2} [(6+30+25) - (25-10-18)] \\ &= \frac{1}{2} [61 + 3] \\ &= \frac{|64|}{2} = 32 \text{ sq. units.} \end{aligned}$$

2. Show that the points P (-1.5, 3), Q (6, -2), R (-3, 4) are collinear. MAY-22

Solution:

$$\text{Area of } \Delta PQR = 0$$

$$\frac{1}{2} \begin{vmatrix} x_1 & y_1 \\ x_2 & y_2 \\ x_3 & y_3 \end{vmatrix} = 0 \Rightarrow \frac{1}{2} \begin{vmatrix} -1.5 & 3 \\ 6 & -2 \\ -3 & 4 \end{vmatrix} = 0$$

$$\frac{1}{2} [(3+24-9) - (18+6-6)] = 0$$

$$\frac{1}{2} [18 - 18] = 0$$

∴ Therefore, the given points are collinear.

3. If the area of the triangle formed by the vertices A (-1, 2), B (k, -2) and C (7, 4) (taken in order) is 22 sq. units, find the value of k.

Solution:

The vertices are A (-1, 2), B (k, -2) and C (7, 4)

Area of ΔABC is 22 sq. units

$$\frac{1}{2} \begin{vmatrix} -1 & 2 \\ k & -2 \\ 7 & 4 \end{vmatrix} = 22$$

$$\begin{vmatrix} -1 & 2 \\ k & -2 \\ 7 & 4 \end{vmatrix} = 44$$

$$\{(2 + 4k + 14) - (2k - 14 - 4)\} = 44$$

$$4k + 16 - 2k + 18 = 44$$

$$2k + 34 = 44$$

$$2k = 10$$

$$\text{Therefore } k = 5$$

4. Find the area of the triangle formed by the points (i) (1, -1), (-4, 6) and (-3, -5)
(ii) (-10, -4), (-8, -1) and (-3, -5)

Solution:

$$\begin{aligned} \text{i. Area of } \Delta &= \frac{1}{2} \begin{vmatrix} x_1 & y_1 \\ x_2 & y_2 \\ x_3 & y_3 \end{vmatrix} = \frac{1}{2} \begin{vmatrix} 1 & -1 \\ -4 & 6 \\ -3 & -5 \end{vmatrix} \\ &= \frac{1}{2} [(6+20+3) - (4-18-5)] \\ &= \frac{1}{2} [6+20+3-4+18+5] \\ &= \frac{1}{2} [(6+20+3+18+5)-4] \\ &= \frac{1}{2} [52-4] \\ &= \frac{1}{2} [48] = 24 \text{ sq. units.} \end{aligned}$$

$$\begin{aligned} \text{ii. Area of } \Delta &= \frac{1}{2} \begin{vmatrix} x_1 & y_1 \\ x_2 & y_2 \\ x_3 & y_3 \end{vmatrix} = \frac{1}{2} \begin{vmatrix} -10 & -4 \\ -8 & -1 \\ -3 & -5 \end{vmatrix} \\ &= \frac{1}{2} [(10+40+12) - (32+3+50)] \\ &= \frac{1}{2} [62 - 85] \\ &= \frac{1}{2} [-23] = -11.5 \text{ sq. units.} \end{aligned}$$

∴ Area of the Triangle = 11.5 sq. units

5. Determine whether the sets of points are collinear?

$$\text{(i) } \left(-\frac{1}{2}, 3\right), (-5, 6) \text{ and } (-8, 8)$$

Solution:

$$\left(-\frac{1}{2}, 3\right), (-5, 6) \text{ and } (-8, 8)$$

$$\begin{aligned} \text{Area of } \Delta &= \frac{1}{2} \begin{vmatrix} x_1 & y_1 \\ x_2 & y_2 \\ x_3 & y_3 \end{vmatrix} = \frac{1}{2} \begin{vmatrix} -\frac{1}{2} & 3 \\ -5 & 6 \\ -8 & 8 \end{vmatrix} \\ &= \frac{1}{2} [(-3-40-24) - (-15-48-4)] \\ &= \frac{1}{2} [(-67) - (-67)] = 0 \end{aligned}$$

∴ The given points are collinear.

(ii) (a, b+c), (b, c+a) and (c, a+b)

Solution:

$$\begin{aligned} \text{Area of } \Delta &= \frac{1}{2} \begin{vmatrix} x_1 & y_1 \\ x_2 & y_2 \\ x_3 & y_3 \end{vmatrix} = \frac{1}{2} \begin{vmatrix} a & b+c \\ b & c+a \\ c & a+b \end{vmatrix} \\ &= \frac{1}{2} [(ac + a^2 + ab + b^2 + bc + c^2) - \\ &\quad (b^2 + bc + c^2 + ca + a^2 + ab)] \\ &= \frac{1}{2} [ac + a^2 + ab + b^2 + bc + c^2 - b^2 - bc - c^2 - \\ &\quad ca - a^2 - ab] \\ &= \frac{1}{2} [0] = 0 \text{ sq.units.} \end{aligned}$$

Aliter:

(a, b+c), (b, c+a), (c, a+b)

x_1, y_1 x_2, y_2 x_3, y_3

$$\begin{aligned} \text{Area of } \Delta &= \frac{1}{2} \begin{vmatrix} x_1 - x_2 & x_1 - x_3 \\ y_1 - y_2 & y_1 - y_3 \end{vmatrix} \\ &= \frac{1}{2} \begin{vmatrix} a-b & a-c \\ b+c-c-a & b+c-a-b \end{vmatrix} \\ &= \frac{1}{2} \begin{vmatrix} a-b & a-c \\ -(a-b) & -(a-c) \end{vmatrix} \\ &= \frac{1}{2} [(a-b)(a-c) + (a-b)(a-c)] \\ &= \frac{1}{2} [0] = 0 \end{aligned}$$

\therefore The given points are collinear.

6. Vertices of given triangles are taken in order and their areas are provided aside. In each case, find the value of 'p'.

S.No.	Vertices	Area (sq.units)
(i)	(0, 0), (p, 8), (6, 2)	20
(ii)	(p, p), (5, 6), (5, -2)	32

Solution:

- i. A (0, 0), B (p, 8), C (6, 2)

Area of $\Delta ABC = 20$ sq.units.

$$\begin{aligned} \frac{1}{2} \begin{vmatrix} x_1 & y_1 \\ x_2 & y_2 \\ x_3 & y_3 \end{vmatrix} &= \text{Area of } \Delta ABC \\ \frac{1}{2} \begin{vmatrix} 0 & 0 \\ p & 8 \\ 6 & 2 \end{vmatrix} &= 20 \end{aligned}$$

$$\begin{aligned} (0+2p+0) - (0+48+0) &= 40 \\ 2p - 48 &= 40 \\ 2p &= 88 \\ p &= 44 \end{aligned}$$

- ii. A (p, p), B (5, 6), C (5, -2)

Area of $\Delta = 32$ sq.units

$$\frac{1}{2} \begin{vmatrix} x_1 & y_1 \\ x_2 & y_2 \\ x_3 & y_3 \end{vmatrix} = 32$$

$$\frac{1}{2} \begin{vmatrix} p & p \\ 5 & 6 \\ 5 & -2 \end{vmatrix} = 32$$

$$\begin{vmatrix} p & p \\ 5 & 6 \\ 5 & -2 \end{vmatrix} = 64$$

$$\begin{aligned} (6p-10+5p) - (5p+30-2p) &= 64 \\ 6p - 10 + 5p - 5p - 30 + 2p &= 64 \\ 8p - 40 &= 64 \\ \Rightarrow 8p &= 64 + 40 \\ 8p &= 104 \\ \Rightarrow p &= \frac{104}{8} \\ \Rightarrow p &= 13 \end{aligned}$$

7. In each of the following, find the value of 'a' for which the given points are collinear.

(i) (2, 3), (4, a) and (6, -3)

(ii) (a, 2-2a), (-a+1, 2a) and (-4-a, 6-2a)

Solution:

- i. (2, 3), (4, a) and (6, -3)

$\Delta = 0$

$$\begin{vmatrix} x_1 & y_1 \\ x_2 & y_2 \\ x_3 & y_3 \end{vmatrix} = 0 \quad \Rightarrow \quad \begin{vmatrix} 2 & 3 \\ 4 & a \\ 6 & -3 \end{vmatrix} = 0$$

$$[(2a-12+18) - (12+6a-6)] = 0$$

$$2a - 12 + 18 - 12 - 6a + 6 = 0$$

$$-4a = 0$$

$$\therefore a = 0$$

ii. $(a, 2-2a)$, $(-a+1, 2a)$ and $(-4-a, 6-2a)$

$\Delta = 0$ sq.units.

$$(2a^2 - 6a + 2a^2 + 6 - 2a - 8 + 8a - 2a + 2a^2) - (-2a + 2a^2 + 2 - 2a - 8a - 2a^2 + 6a - 2a^2) = 0$$

$$\Rightarrow (6a^2 - 2a - 2) - (-2a^2 - 6a + 2) = 0$$

$$\Rightarrow 8a^2 + 4a - 4 = 0 \div 4$$

$$2a^2 + a - 1 = 0$$

$$(a+1)(2a-1) = 0$$

$$\Rightarrow \therefore a = +\frac{1}{2} \text{ and } a = -1$$

Aliter:

$(a, a-2a)$, $(-a+1, 2a)$, $(-4-a, 6-2a)$

x_1, y_1 x_2, y_2 x_3, y_3

$$\text{Area of } \Delta = \frac{1}{2} \begin{vmatrix} x_1 - x_2 & x_1 - x_3 \\ y_1 - y_2 & y_1 - y_3 \end{vmatrix} = 0$$

$$\begin{vmatrix} a + a - 1 & a + 4 + a \\ 2 - 2a - 2a & 2 - 2a - 6 + 2a \end{vmatrix} = 0$$

$$\begin{vmatrix} 2a - 1 & 2a + 4 \\ 2 - 4a & -4 \end{vmatrix} = 0$$

$$-4(2a-1) - (2-4a)(2a+4) = 0$$

$$-8a+4 - [4a+8-8a^2-16a] = 0$$

$$-8a+4-4a-8+8a^2+16a = 0$$

$$8a^2+4a-4 = 0$$

$$2a^2+a-1 = 0$$

$$(a+1)(2a-1) = 0$$

$$a = -1 \text{ (or) } a = \frac{1}{2}$$

5 Marks

1. The floor of a hall is covered with identical tiles which are in the shapes of triangles. One such triangle has the vertices at $(-3, 2)$, $(-1, -1)$ and $(1, 2)$. If the floor of the hall is completely covered by 110 tiles, find the area of the floor.

Solution:

Vertices of one triangular tile are at

$(-3, 2)$, $(-1, -1)$ $(1, 2)$

$$\begin{aligned} \text{Area of this tile} &= \frac{1}{2} \begin{vmatrix} -3 & 2 \\ -1 & -1 \\ 1 & 2 \end{vmatrix} \\ &= \frac{1}{2} \{(3-2+2)-(-2-1-6)\} \\ &= \frac{1}{2} (12) = 6 \text{ sq.units} \end{aligned}$$

Since the floor is covered by 110 triangle shaped identical tiles,

Area of the floor = $110 \times 6 = 660$ sq. units

2. Find the area of the quadrilateral formed by the points $(8, 6)$, $(5, 11)$, $(-5, 12)$ and $(-4, 3)$.

Solution:

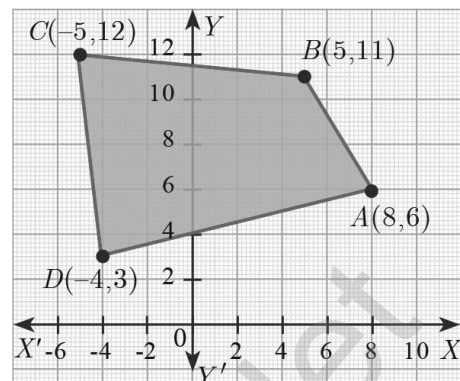

Before determining the area of the

quadrilateral, plot the vertices in a graph

A $(8, 6)$, B $(5, 11)$, C $(-5, 12)$ and D $(-4, 3)$.

Therefore, area of the quadrilateral ABCD

$$\begin{aligned} &\frac{1}{2} \begin{vmatrix} x_1 & y_1 \\ x_2 & y_2 \\ x_3 & y_3 \\ x_4 & y_4 \\ x_1 & y_1 \end{vmatrix} = \frac{1}{2} \begin{vmatrix} 8 & 6 \\ 5 & 11 \\ -5 & 12 \\ -4 & 3 \\ 8 & 6 \end{vmatrix} \\ &= \frac{1}{2} [(88 + 60 - 15 - 24) - (30 - 55 - 48 + 24)] \\ &= \frac{1}{2} [88 + 60 - 15 - 24 - 30 + 55 + 48 - 24] \\ &= \frac{1}{2} [88 + 60 + 55 + 48 - 15 - 24 - 30 - 24] \\ &= \frac{1}{2} [251 - 93] \\ &= \frac{1}{2} [158] = 79 \text{ sq.units.} \end{aligned}$$

3. The given diagram shows a plan for constructing a new parking lot at a campus. It is estimated that such construction would cost ₹ 1300 per square feet. What will be the total cost for making the parking lot?

Solution:

The parking lot is a quadrilateral whose vertices

A $(2, 2)$, B $(5, 5)$, C $(4, 9)$ and D $(1, 7)$.

Therefore, Area of parking lot is

$$\frac{1}{2} \begin{vmatrix} x_1 & y_1 \\ x_2 & y_2 \\ x_3 & y_3 \\ x_4 & y_4 \\ x_1 & y_1 \end{vmatrix} = \frac{1}{2} \begin{vmatrix} 2 & 2 \\ 5 & 5 \\ 4 & 9 \\ 1 & 7 \\ 2 & 2 \end{vmatrix}$$

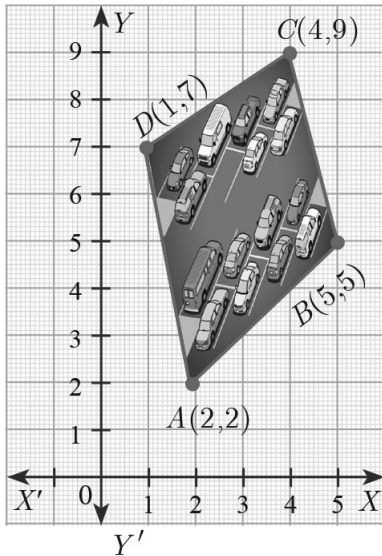

$$\begin{aligned}
 &= \frac{1}{2} [(10 + 45 + 28 + 2) - (10 + 20 + 9 + 14)] \\
 &= \frac{1}{2} [85 - 53] \\
 &= \frac{1}{2} [32] = 16 \text{ sq. units}
 \end{aligned}$$

So, Area of parking lot = 16 sq. feet.

Construction rate per square fee = ₹ 1300

Therefore, total cost for constructing the parking lot = $16 \times 1300 = ₹ 20,800$

4. Find the area of the quadrilateral whose vertices are at

(i) $(-9, -2)$, $(-8, -4)$, $(2, 2)$ and $(1, -3)$

Solution:

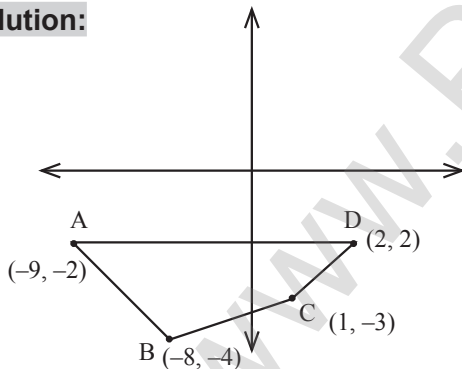

Let A $(-9, -2)$, B $(-8, -4)$, C $(1, -3)$, D $(2, 2)$

$$\begin{aligned}
 \text{Area of the quadrilateral} &= \frac{1}{2} \begin{vmatrix} -9 & -2 \\ -8 & -4 \\ 1 & -3 \\ 2 & 2 \\ -9 & -2 \end{vmatrix} \\
 &= \frac{1}{2} [(36+24+2-4) - (16-4-6-18)] \\
 &= \frac{1}{2} [(36+24+2-4-16+4+6+18)] \\
 &= \frac{1}{2} [(36+24+2+4+6+18) - (4+16)]
 \end{aligned}$$

$$\begin{aligned}
 &= \frac{1}{2} [90 - (20)] \\
 &= \frac{1}{2} [70] = 35 \text{ sq. units}
 \end{aligned}$$

(ii) $(-9, 0)$, $(-8, 6)$, $(-1, -2)$ and $(-6, -3)$

Solution:

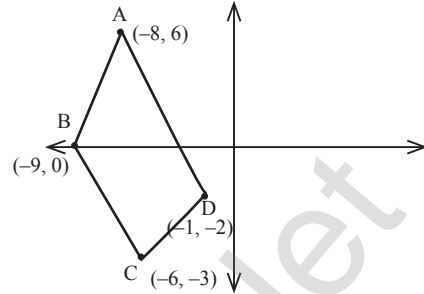

A $(-8, 6)$, B $(-9, 0)$, C $(-6, -3)$, D $(-1, -2)$

$$\text{Area of the quadrilateral} = \frac{1}{2} \begin{vmatrix} -8 & 6 \\ -9 & 0 \\ -6 & -3 \\ -1 & -2 \\ -8 & 6 \end{vmatrix}$$

$$= \frac{1}{2} [(0+27+12-6) - (-54+0+3+16)]$$

$$= \frac{1}{2} [27+12-6+54-3-16]$$

$$= \frac{1}{2} [(27+12+54) - (6+3+16)]$$

$$= \frac{1}{2} [93-25] = \frac{1}{2} [68] = 34 \text{ sq. units}$$

Aliter:

A $(-8, 6)$, B $(-9, 0)$, C $(-6, -3)$, D $(-1, -2)$

x_1, y_1 x_2, y_2 x_3, y_3 x_4, y_4

Area of the quadrilateral

$$= \frac{1}{2} \begin{vmatrix} x_1 - x_3 & x_2 - x_4 \\ y_1 - y_3 & y_2 - y_4 \end{vmatrix}$$

$$= \frac{1}{2} \begin{vmatrix} -8 - (-6) & -9 - (-1) \\ 6 - (-3) & 0 - (-2) \end{vmatrix}$$

$$= \frac{1}{2} \begin{vmatrix} -8+6 & -9+1 \\ 6+3 & 0+2 \end{vmatrix} = \frac{1}{2} \begin{vmatrix} -2 & -8 \\ 9 & 2 \end{vmatrix}$$

$$= \frac{1}{2} [-4 + 72] = \frac{1}{2} [68] = 34 \text{ sq. units}$$

5. Find the value of k , if the area of a quadrilateral is 28 sq.units, whose vertices are $(-4, -2)$, $(-3, k)$, $(3, -2)$ and $(2, 3)$ **SEP-20**

Solution:

$$\frac{1}{2} \begin{vmatrix} -4 & -2 \\ -3 & k \\ 3 & -2 \\ 2 & 3 \\ -4 & -2 \end{vmatrix} = 28$$

$$\begin{aligned} \Rightarrow & (-4k + 6 + 9 - 4) - (6 + 3k - 4 - 12) = 56 \\ \Rightarrow & (11 - 4k) - (3k - 10) = 56 \\ \Rightarrow & 11 - 4k - 3k + 10 = 56 \\ \Rightarrow & 21 - 7k = 56 \\ \Rightarrow & 7k = -35 \\ \Rightarrow & k = -5 \end{aligned}$$

6. If the points A $(-3, 9)$, B (a, b) and C $(4, -5)$ are collinear and if $a + b = 1$, then find a and b .

Solution:

Given A $(-3, 9)$, B (a, b) , C $(4, -5)$ are collinear and $a + b = 1$ (1)

Area of the triangle formed by 3 points = 0

$$\frac{1}{2} \begin{vmatrix} -3 & 9 \\ a & b \\ 4 & -5 \\ -3 & 9 \end{vmatrix} = 0$$

$$\begin{aligned} \Rightarrow & (-3b - 5a + 36) - (9a + 4b + 15) = 0 \\ \Rightarrow & -5a - 3b + 36 - 9a - 4b - 15 = 0 \\ \Rightarrow & -14a - 7b + 21 = 0 \\ \Rightarrow & -14a - 7b = -21 \\ \Rightarrow & 14a + 7b = 21 \quad (\div 7) \\ \Rightarrow & 2a + b = 3 \quad \text{..... (2)} \end{aligned}$$

Given $a + b = 1$ (1)

$$(1) - (2) \Rightarrow a = 2 \quad b = -1$$

7. A triangular shaped glass with vertices at A $(-5, -4)$, B $(1, 6)$ and C $(7, -4)$ has to be painted. If one bucket of paint covers 6 square feet, how many buckets of paint will be required to paint the whole glass, if only one coat of paint is applied.

Solution:

$$\frac{\text{The required number of buckets} = \frac{\text{Area of the } \Delta ABC}{\text{Area of the paint covered by one bucket}}}$$

$$\begin{aligned} \text{Area of the } \Delta ABC &= \frac{1}{2} \begin{vmatrix} x_1 & y_1 \\ x_2 & y_2 \\ x_3 & y_3 \\ x_1 & y_1 \end{vmatrix} = \frac{1}{2} \begin{vmatrix} -5 & -4 \\ 1 & 6 \\ 7 & -4 \\ -5 & -4 \end{vmatrix} \\ &= \frac{1}{2} [(-30 - 4 - 28) - (-4 + 42 + 20)] \\ &= \frac{1}{2} [-62 - 58] \\ &= \frac{1}{2} [-120] \\ &= 60 \text{ sq. units.} \end{aligned}$$

$$\therefore \text{The required number of buckets} = \frac{60}{6} = 10$$

6. Trigonometry

2 Marks

1. Prove that $\frac{\sin A}{1 + \cos A} = \frac{1 - \cos A}{\sin A}$

Solution:

$$\begin{aligned} \frac{\sin A}{1 + \cos A} &= \frac{\sin A}{1 + \cos A} \times \frac{1 - \cos A}{1 - \cos A} \\ &= \frac{\sin A(1 - \cos A)}{(1 + \cos A)(1 - \cos A)} \\ &= \frac{\sin A(1 - \cos A)}{1 - \cos^2 A} \\ &= \frac{\sin A(1 - \cos A)}{\sin^2 A} = \frac{1 - \cos A}{\sin A} \end{aligned}$$

2. Prove that $1 + \frac{\cot^2 \theta}{1 + \operatorname{cosec} \theta} = \operatorname{cosec} \theta$

Solution:

$$\begin{aligned} 1 + \frac{\cot^2 \theta}{1 + \operatorname{cosec} \theta} &= 1 + \frac{\operatorname{cosec}^2 \theta - 1}{\operatorname{cosec} \theta + 1} \\ & \quad [\because \operatorname{cosec}^2 \theta - 1 = \cot^2 \theta] \\ &= 1 + \frac{(\operatorname{cosec} \theta + 1)(\operatorname{cosec} \theta - 1)}{\operatorname{cosec} \theta + 1} \\ &= 1 + (\operatorname{cosec} \theta - 1) = \operatorname{cosec} \theta \end{aligned}$$

3. Prove that $\sqrt{\frac{1 + \cos \theta}{1 - \cos \theta}} = \operatorname{cosec} \theta + \cot \theta$

Solution:

$$\sqrt{\frac{1 + \cos \theta}{1 - \cos \theta}} = \sqrt{\frac{1 + \cos \theta}{1 - \cos \theta} \times \frac{1 + \cos \theta}{1 + \cos \theta}}$$

$$\begin{aligned}
 &= \sqrt{\frac{(1+\cos\theta)^2}{1-\cos^2\theta}} = \sqrt{\frac{(1+\cos\theta)^2}{\sin^2\theta}} \\
 &= \sqrt{\left(\frac{1+\cos\theta}{\sin\theta}\right)^2} = \frac{1+\cos\theta}{\sin\theta} \\
 &= \frac{1}{\sin\theta} + \frac{\cos\theta}{\sin\theta}
 \end{aligned}$$

$$\text{LHS} = \text{cosec}\theta + \cot\theta$$

$$\therefore \text{LHS} = \text{RHS}$$

4. Prove the following identities.

(i) $\cot\theta + \tan\theta = \sec\theta \text{ cosec}\theta$

Solution:

$$\begin{aligned}
 \text{LHS} &= \cot\theta + \tan\theta \\
 &= \frac{\cos\theta}{\sin\theta} + \frac{\sin\theta}{\cos\theta} \\
 &= \frac{\cos^2\theta + \sin^2\theta}{\sin\theta\cos\theta} = \frac{1}{\sin\theta\cos\theta} \\
 &= \sec\theta \text{ cosec}\theta
 \end{aligned}$$

$$\therefore \text{LHS} = \text{RHS}$$

(ii) $\tan^4\theta + \tan^2\theta = \sec^4\theta - \sec^2\theta$

Solution:

$$\begin{aligned}
 \text{LHS} &= \tan^4\theta + \tan^2\theta = \tan^2\theta (\tan^2\theta + 1) \\
 &= \tan^2\theta (\sec^2\theta) \quad (\because 1 + \tan^2\theta = \sec^2\theta) \\
 &= (\sec^2\theta - 1) (\sec^2\theta) \quad (\because \tan^2\theta = \sec^2\theta - 1) \\
 &= \sec^4\theta - \sec^2\theta
 \end{aligned}$$

$$\therefore \text{LHS} = \text{RHS}$$

5. Prove the following identities.

(i) $\sqrt{\frac{1+\sin\theta}{1-\sin\theta}} = \sec\theta \tan\theta$

SEP-20

Solution:

$$\begin{aligned}
 \text{LHS} &= \sqrt{\frac{1+\sin\theta}{1-\sin\theta}} \times \sqrt{\frac{1+\sin\theta}{1+\sin\theta}} \\
 &= \sqrt{\frac{(1+\sin\theta)^2}{1-\sin^2\theta}} = \sqrt{\frac{(1+\sin\theta)^2}{\cos^2\theta}} \\
 &= \frac{1+\sin\theta}{\cos\theta} = \frac{1}{\cos\theta} + \frac{\sin\theta}{\cos\theta} \\
 &= \sec\theta + \tan\theta = \text{RHS}
 \end{aligned}$$

Hence Proved.

(ii) $\sqrt{\frac{1+\sin\theta}{1-\sin\theta}} + \sqrt{\frac{1-\sin\theta}{1+\sin\theta}} = 2\sec\theta$

Solution:

$$\begin{aligned}
 \text{LHS} &= \sqrt{\frac{1+\sin\theta}{1-\sin\theta}} \times \frac{1+\sin\theta}{1+\sin\theta} \\
 &\quad + \sqrt{\frac{1-\sin\theta}{1+\sin\theta}} \times \frac{1-\sin\theta}{1-\sin\theta}
 \end{aligned}$$

$$\begin{aligned}
 &= \sqrt{\frac{(1+\sin\theta)^2}{1-\sin^2\theta}} + \sqrt{\frac{(1-\sin\theta)^2}{1-\sin^2\theta}} \\
 &= \sqrt{\frac{(1+\sin\theta)^2}{\cos^2\theta}} + \sqrt{\frac{(1-\sin\theta)^2}{\cos^2\theta}} \\
 &= \frac{1+\sin\theta}{\cos\theta} + \frac{1-\sin\theta}{\cos\theta} \\
 &= \frac{1+\sin\theta+1-\sin\theta}{\cos\theta} = \frac{2}{\cos\theta} \\
 &= 2\sec\theta
 \end{aligned}$$

Hence Proved.

6. A tower stands vertically on the ground. From a point on the ground, which is 48 m away from the foot of the tower, the angle of elevation of the top of the tower is 30° . Find the height of the tower.

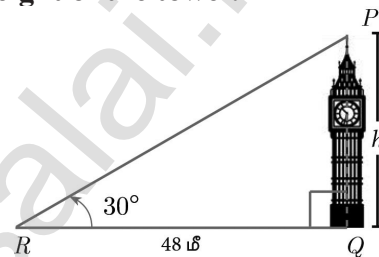

Solution:

$$\text{In } \triangle PQR \quad \tan\theta = \frac{PQ}{QR}$$

$$\tan 30^\circ = \frac{h}{48}$$

$$\frac{1}{\sqrt{3}} = \frac{h}{48}$$

$$h = \frac{48}{\sqrt{3}} \times \frac{\sqrt{3}}{\sqrt{3}} = \frac{48\sqrt{3}}{3} = 16\sqrt{3}$$

Therefore the height of the tower is,

$$h = 16\sqrt{3} \text{ m}$$

7. A kite is flying at a height of 75 m above the ground. The string attached to the kite is temporarily tied to a point on the ground. The inclination of the string with the ground is 60° . Find the length of the string, assuming that there is no slack in the string.

Solution:

$$\text{In } \triangle ABC \quad \sin\theta = \frac{AB}{AC}$$

$$\sin 60^\circ = \frac{75}{AC}$$

$$\frac{\sqrt{3}}{2} = \frac{75}{AC}$$

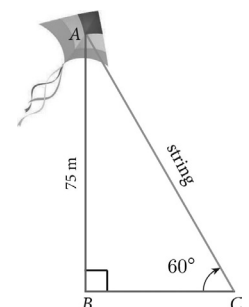

$$AC = \frac{75 \times 2}{\sqrt{3}} \times \frac{\sqrt{3}}{\sqrt{3}} = \frac{150\sqrt{3}}{3}$$

$$AC = 50\sqrt{3} \text{ m}$$

∴ Hence, the length of the string is $50\sqrt{3}$ m.

8. Find the angle of elevation of the top of a tower from a point on the ground, which is 30 m away from the foot of a tower of height $10\sqrt{3}$ m.

SEP-21

Solution:

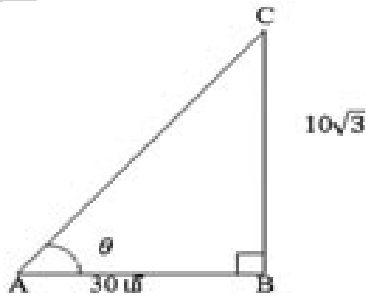
In $\triangle ABC$

$$\tan \theta = \frac{\text{opposite side}}{\text{Adjacent side}} \Rightarrow \tan \theta = \frac{10\sqrt{3}}{30}$$

$$\tan \theta = \frac{\sqrt{3}}{3} \Rightarrow \tan \theta = \frac{\sqrt{3}}{\sqrt{3}\sqrt{3}}$$

$$\tan \theta = \frac{1}{\sqrt{3}} \quad \theta = 30^\circ$$

9. A road is flanked on either side by continuous rows of houses of height $4\sqrt{3}$ m with no space in between them. A pedestrian is standing on the median of the road facing a row house. The angle of elevation from the pedestrian to the top of the house is 30° . Find the width of the road.

Solution:

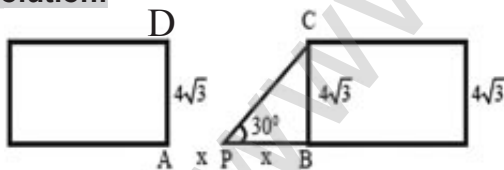

In the figure, BC – House, AB – Width of Road, P – Median of Road

$$AP = PB = x$$

$$\text{In } \triangle PBC, \tan 30^\circ = \frac{BC}{PB}$$

$$\Rightarrow \tan 30^\circ = \frac{4\sqrt{3}}{PB} \Rightarrow \frac{1}{\sqrt{3}} = \frac{4\sqrt{3}}{PB}$$

$$PB = 4\sqrt{3} \times \sqrt{3} = 4 \times 3 = 12$$

Hence, Width of Road

$$= AP + PB = 12 + 12 = 24 \text{ m}$$

10. A player sitting on the top of a tower of height 20 m observes the angle of depression of a ball lying on the ground as 60° . Find the distance between the foot of the tower and the ball. ($\sqrt{3} = 1.732$)

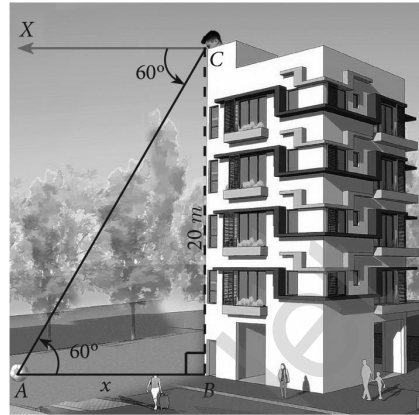

Solution:

Let BC be the height of the tower and A be the position of the ball lying on the ground.

Then, BC = 20 m and

$$\angle XCA = 60^\circ = \angle CAB$$

Let AB = x metres.

In the right angled triangle ABC,

$$\tan 60^\circ = \frac{20}{AB}$$

$$\sqrt{3} = \frac{20}{AB}$$

$$AB = \frac{20}{\sqrt{3}} \times \frac{\sqrt{3}}{\sqrt{3}}$$

$$AB = \frac{20\sqrt{3}}{3} = \frac{20 \times 1.732}{3}$$

$$= \frac{34.640}{3} = 11.54 \text{ m}$$

Hence, the distance between the foot of the tower and the ball is 11.55 m.

11. From the top of a rock $50\sqrt{3}$ m high, the angle of depression of a car on the ground is observed to be 30° . Find the distance of the car from the rock.

MAY-22

Solution:

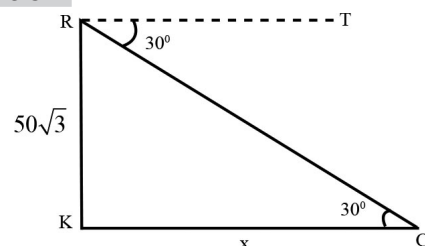

$$\text{In } \triangle ABC, \tan \theta = \frac{\text{opposite side}}{\text{Adjacent side}}$$

$$\begin{aligned}\tan 30^\circ &= \frac{50\sqrt{3}}{KC} \\ \frac{1}{\sqrt{3}} &= \frac{50\sqrt{3}}{KC} \\ KC &= 50\sqrt{3} \times \sqrt{3} \\ &= 50(3) = 150 \text{ m}\end{aligned}$$

12. The horizontal distance between two buildings is 70 m. The angle of depression of the top of the first building when seen from the top of the second building is 45° . If the height of the second building is 120 m, find the height of the first building. ($\sqrt{3} = 1.732$)

Solution:

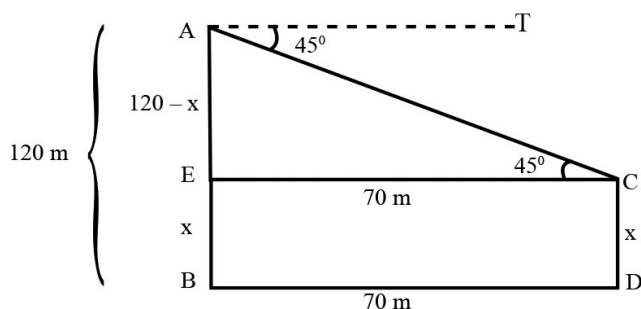

CD – First Building,

AB – Second Building

From the figure $AB = 120 \text{ m}$,

$EB = CD = x$, $AE = 120 - x$,

$EC = BD = 70 \text{ m}$

In $\triangle ACE$, $\tan 45^\circ = \frac{AE}{EC}$

$$\Rightarrow 1 = \frac{120 - x}{70}$$

$$\begin{aligned}\Rightarrow 120 - x &= 70 \text{ m} \\ \therefore x &= 50 \text{ m}\end{aligned}$$

7. Mensuration

2 Marks

1. The slant height of a frustum of a cone is 5 cm and the radii of its ends are 4 cm and 1 cm. Find its curved surface area.

Solution:

$$l = 5 \text{ cm}, R = 4 \text{ cm}, r = 1 \text{ cm}$$

$$\begin{aligned}\text{C.S.A of the frustum} &= \pi(R + r)l \text{ sq. units} \\ &= \frac{22}{7}(4+1) \times 5 \\ &= \frac{22 \times 5 \times 5}{7} = \frac{550}{7} \\ &= 78.57 \text{ cm}^2\end{aligned}$$

2. The radius and height of a cylinder are in the ratio 5:7 and its curved surface area is 5500 sq.cm. Find its radius and height.

Solution:

$$r : h = 5 : 7 \Rightarrow r = 5x \text{ cm}, h = 7x \text{ cm}$$

$$\text{CSA} = 5500 \text{ sq.cm}$$

$$2\pi rh = 5500 \Rightarrow 2 \times \frac{22}{7} \times 5x \times 7x = 5500$$

$$x^2 = \frac{5500}{2 \times 22 \times 5} = 25 \Rightarrow x = 5$$

$$\text{Hence, Radius} = 5 \times 5 = 25 \text{ cm,}$$

$$\text{Height} = 7 \times 5 = 35 \text{ cm}$$

3. The volumes of two cones of same base radius are 3600 cm^3 and 5040 cm^3 . Find the ratio of heights. [May 22]

Solution:

Ratio of the volumes of two cones

$$= \frac{1}{3} \pi r^2 h_1 : \frac{1}{3} \pi r^2 h_2$$

$$= h_1 : h_2$$

$$= 3600 : 5040$$

$$= 360 : 504$$

$$= 40 : 56$$

$$= 5 : 7$$

4. If the ratio of radii of two spheres is 4:7, find the ratio of their volumes.

Solution:

The ratio of radii of two spheres = 4 : 7

Let radius of first sphere is $4x$,

that is $r_1 = 4x$

Let radius of second sphere is $7x$,

that is $r_2 = 7x$

The ratio of their volumes

$$= \frac{\frac{4}{3}\pi r_1^3}{\frac{4}{3}\pi r_2^3} = \frac{r_1^3}{r_2^3} = \frac{(4x)^3}{(7x)^3} = \frac{4^3 \times x^3}{7^3 \times x^3}$$

$$= \frac{4^3}{7^3} = \frac{64}{343}$$

Hence the ratio of the volumes is 64 : 343

5. A solid sphere and a solid hemisphere have equal total surface area. Prove that the ratio of their volume is $3\sqrt{3} : 4$.

Solution:

Given

Total Surface Area of a solid Sphere

= Total surface Area of a solid hemisphere

$$\Rightarrow 4\pi R^2 = 3\pi r^2$$

$$\Rightarrow \therefore \frac{R^2}{r^2} = \frac{3}{4} \quad \Rightarrow \therefore \frac{R}{r} = \frac{\sqrt{3}}{2}$$

\therefore Ratio of their volumes

$$= \frac{\frac{4}{3}\pi R^3}{\frac{2}{3}\pi r^3} = \frac{2R^3}{r^3} = 2 \left[\frac{R}{r} \right]^3 = 2 \left[\frac{\sqrt{3}}{2} \right]^3$$

$$\Rightarrow 2 \times \frac{3\sqrt{3}}{8} = \frac{3\sqrt{3}}{4}$$

\therefore Ratio of their volumes = $3\sqrt{3} : 4$

5 Marks

1. An industrial metallic bucket is in the shape of the frustum of a right circular cone whose top and bottom diameters are 10 m and 4 m and whose height is 4 m. Find the curved and total surface area of the bucket.

Solution:

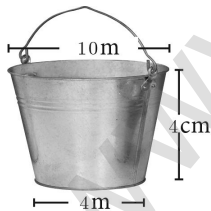

Let h , l , R and r be the height, slant height, outer radius and inner radius of the frustum.

Given that, diameter of the top = 10 m;

radius of the top $R = 5$ m.

diameter of the bottom = 4 m;

radius of the bottom $r = 2$ m, height $h = 4$ m

$$\text{Now, } l = \sqrt{h^2 + (R-r)^2}$$

$$= \sqrt{4^2 + (5-2)^2}$$

$$l = \sqrt{16+9} = \sqrt{25} = 5 \text{ m}$$

$$\text{C.S.A.} = \pi(R+r)l \text{ sq. units}$$

$$= \frac{22}{7} (5+2) \times 5$$

$$= \frac{22}{7} \times 7 \times 5$$

$$= 110 \text{ m}^2$$

$$\text{T.S.A.} = \pi(R+r)l + \pi R^2 + \pi r^2 \text{ sq. units}$$

$$= \pi[(R+r)l + R^2 + r^2]$$

$$= \frac{22}{7} [(5+2)5 + 5^2 + 2^2]$$

$$= \frac{22}{7} (35+25+4) = \frac{1408}{7} = 201.14 \text{ m}^2$$

Therefore, C.S.A. = 110 m² and

$$\text{T.S.A.} = 201.14 \text{ m}^2$$

2. The frustum shaped outer portion of the table lamp has to be painted including the top part. Find the total cost of painting the lamp if the cost of painting 1 sq.cm is ₹ 2.

Solution:



From the given figure, $r = 6$ m, $R = 12$ m and $h = 8$ m.

$$\text{But, } l = \sqrt{h^2 + (R-r)^2}$$

$$= \sqrt{8^2 + 6^2} = \sqrt{100} = 10$$

$$l = 10 \text{ m}$$

The required total area of table lamp

= CSA of frustum + Area of the top

$$= \pi(R+r)l + \pi r^2$$

$$= \frac{22}{7} \times 18 \times 10 + \frac{22}{7} \times 6 \times 6$$

$$= \frac{22}{7} \times 6[30+6] = \frac{22}{7} \times 6 \times 36$$

$$= 678.86 \text{ m}^2$$

Cost of painting for 1 sq.m. is ₹ 2.

\therefore The total cost of painting

$$= 678.86 \times 2 = ₹ 1357.72.$$

3. A container open at the top is in the form of a frustum of a cone of height 16 cm with radii of its lower and upper ends are 8 cm and 20 cm respectively. Find the cost of milk which can completely fill a container at the rate of ₹40 per litre.

MAY-22

Solution:

$$h = 16 \text{ cm, } r = 8 \text{ cm, } R = 20 \text{ cm,}$$

Volume of the frustum

$$= \frac{1}{3} \pi h [R^2 + Rr + r^2] \text{ cu. units}$$

$$= \frac{1}{3} \times \frac{22}{7} \times 16 [20^2 + 20(8) + 8^2]$$

$$= \frac{1}{3} \times \frac{22}{7} \times 16 [400 + 160 + 64]$$

$$= \frac{1}{3} \times \frac{22}{7} \times 16 \times 624$$

$$= 10459 \text{ cm}^3$$

$$= 10.459 \text{ litre}$$

The cost of milk is ₹ 40 per litre

$$\begin{aligned} \text{The cost of 10.459 litres milk} &= 10.459 \times 40 \\ &= ₹ 418.36 \end{aligned}$$

4. If the radii of the circular ends of a frustum which is 45 cm high are 28 cm and 7 cm, find the volume of the frustum.

SEP-21

Solution:height of the frustum, $h = 45 \text{ cm,}$ bottom radii, $R = 28 \text{ cm,}$ top radii, $r = 7 \text{ cm}$

Volume of the frustum

$$= \frac{1}{3} \pi h [R^2 + Rr + r^2] \text{ cu. units}$$

$$= \frac{1}{3} \times \frac{22}{7} \times 45 [28^2 + 28 \times 7 + 7^2]$$

$$= \frac{1}{3} \times \frac{22}{7} \times 45 [784 + 196 + 49]$$

$$= \frac{1}{3} \times \frac{22}{7} \times 45 \times 1029$$

$$= 22 \times 15 \times 147 = 48510 \text{ cm}^3$$

8. Statistics and Probability

2 Marks

1. Find the range and coefficient of range of the following data: 25, 67, 48, 53, 18, 39, 44.

Solution:Largest value $L = 67$; Smallest value $S = 18$

$$\text{Range } R = L - S = 67 - 18 = 49$$

$$\text{Coefficient of range} = \frac{L - S}{L + S}$$

$$\text{Coefficient of range} = \frac{67 - 18}{67 + 18} = \frac{49}{85} = 0.576$$

2. Find the range of the following distribution.

Age (in years)	16-18	18-20	20-22	22-24	24-26	26-28
Number of students	0	4	6	8	2	2

Solution:

Here

Largest value, $L = 28$ Smallest Value, $S = 18$

$$\text{Range } R = L - S$$

$$R = 28 - 18 = 10 \text{ Years.}$$

3. The range of a set of data is 13.67 and the largest value is 70.08. Find the smallest value.

Solution:

$$\text{Range } R = 13.67$$

Largest value $L = 70.08$

$$\text{Range } R = L - S$$

$$13.67 = 70.08 - S$$

$$S = 70.08 - 13.67 = 56.41$$

Therefore, the smallest value is 56.41

4. Find the range and coefficient of range of following data

SEP-20

(i) 63, 89, 98, 125, 79, 108, 117, 68

(ii) 43.5, 13.6, 18.9, 38.4, 61.4, 29.8

Solution:

- i. 63, 89, 98, 125, 79, 108, 117, 68

$$L = 125, S = 63$$

$$\text{Range, } R = L - S = 125 - 63 = 62$$

$$\text{Coefficient of Range} = \frac{L - S}{L + S}$$

$$= \frac{125 - 63}{125 + 63} = \frac{62}{188} = 0.33$$

- ii. 43.5, 13.6, 18.9, 38.4, 61.4, 29.8

$$L = 61.4, S = 13.6$$

$$\text{Range, } R = L - S = 61.4 - 13.6 = 47.8$$

$$\text{Coefficient of Range} = \frac{L - S}{L + S}$$

$$= \frac{47.8}{61.4 + 13.6} = \frac{47.8}{75.0} = 0.64$$

5. If the range and the smallest value of a set of data are 36.8 and 13.4 respectively, then find the largest value.

Solution:

$$\text{Range, } R = 36.8$$

$$\text{Smallest Value, } S = 13.4$$

$$\begin{aligned} \text{Largest Value, } L &= R + S \\ &= 36.8 + 13.4 = 50.2 \end{aligned}$$

6. Calculate the range of the following data.

Income	400-450	450-500	500-550
Number of workers	8	12	30
Income	550-600	600-650	
Number of workers	21	6	

Solution:

$$\text{Given: Largest Value, } L = 650$$

$$\text{Smallest Value, } S = 400$$

$$\therefore \text{Range} = L - S = 650 - 400 = 250$$

7. Find the standard deviation of first 21 natural numbers.

Solution:

Standard Deviation of first 21 natural numbers,

$$\begin{aligned} \sigma &= \sqrt{\frac{n^2 - 1}{12}} \\ &= \sqrt{\frac{(21)^2 - 1}{12}} = \sqrt{\frac{441 - 1}{12}} = \sqrt{\frac{440}{12}} \\ &= \sqrt{36.66} = 6.05 \end{aligned}$$

8. If the standard deviation of a data is 4.5 and if each value of the data is decreased by 5, then find the new standard deviation.

Solution:

standard deviation of a data, $\sigma = 4.5$

each value of the data decreased by 5,

the new standard deviation does not change and it is also 4.5.

9. If the standard deviation of a data is 3.6 and each value of the data is divided by 3, then find the new variance and new standard deviation.

Solution:

The new standard deviation of a data is 3.6, and each of the data is divided by 3 then the new standard deviation is also divided by 3.

$$\text{The new standard deviation} = \frac{3.6}{3} = 1.2$$

$$\begin{aligned} \text{The new variance} &= (\text{Standard Deviation})^2 \\ &= \sigma^2 = (1.2)^2 = 1.44 \end{aligned}$$

10. The mean of a data is 25.6 and its coefficient of variation is 18.75. Find the standard deviation.

Solution:

$$\text{Mean } \bar{x} = 25.6$$

$$\text{Coefficient of variation, C.V.} = 18.75$$

$$\text{C.V.} = \frac{\sigma}{\bar{x}} \times 100$$

$$18.75 = \frac{\sigma}{25.6} \times 100$$

$$\sigma = \frac{18.75 \times 25.6}{100} = 4.8$$

11. The standard deviation and mean of a data are 6.5 and 12.5 respectively. Find the coefficient of variation.

Solution:

$$\text{Co-efficient of variation C.V.} = \frac{\sigma}{\bar{x}} \times 100.$$

$$\sigma = 6.5, \bar{x} = 12.5$$

$$\begin{aligned} \text{CV} &= \frac{\sigma}{\bar{x}} \times 100 = \frac{6.5}{12.5} \times 100 \\ &= \frac{6500}{125} = 52\% \end{aligned}$$

12. If the mean and coefficient of variation of a data are 15 and 48 respectively, then find the value of standard deviation.

Solution:

$$\bar{x} = 15, \text{C.V.} = 48,$$

$$\text{CV} = \frac{\sigma}{\bar{x}} \times 100$$

$$\sigma = \frac{\text{C.V.} \times \bar{x}}{100} = \frac{48 \times 15}{100} = \frac{720}{100} = 7.2$$

13. If $n = 5$, $\bar{x} = 6$, $\Sigma x^2 = 765$, then calculate the coefficient of variation.

Solution:

$$n = 5, \bar{x} = 6, \Sigma x^2 = 765$$

$$\begin{aligned}\sigma &= \sqrt{\frac{\sum x^2}{n} - \left(\frac{\sum x}{n}\right)^2} = \sqrt{\frac{765}{5} - (6)^2} \\ &= \sqrt{153 - 36} = \sqrt{117} \\ &= 10.8\end{aligned}$$

$$\begin{aligned}CV &= \frac{\sigma}{\bar{x}} \times 100\% \\ &= \frac{10.8}{6} \times 100 = \frac{1080}{6} = 180\%\end{aligned}$$

14. A bag contains 5 blue balls and 4 green balls. A ball is drawn at random from the bag. Find the probability that the ball drawn is (i) blue (ii) not blue.

Solution:

Total number of possible outcomes

$$n(S) = 5 + 4 = 9$$

- i) Let A be the event of getting a blue ball.

Number of favourable outcomes for the event A. Therefore, $n(A) = 5$

Probability that the ball drawn is blue.

$$\text{Therefore, } P(A) = \frac{n(A)}{n(S)} = \frac{5}{9}$$

- ii) A will be the event of not getting a blue ball.

$$\text{So } P(\bar{A}) = 1 - P(A) = 1 - \frac{5}{9} = \frac{4}{9}$$

15. Two coins are tossed together. What is the probability of getting different faces on the coins? MAY-22

Solution:

When two coins are tossed together, the sample space is

$$S = \{HH, HT, TH, TT\}; n(S) = 4$$

Let A be the event of getting different faces on the coins.

$$A = \{HT, TH\}; n(A) = 2$$

Probability of getting different faces on the coins is

$$P(A) = \frac{n(A)}{n(S)} = \frac{2}{4} = \frac{1}{2}$$

16. A coin is tossed thrice. What is the probability of getting two consecutive tails?

Solution:

$$S = \{HHH, HHT, HTH, THH, HTT, THT, TTH, TTT\}$$

$$n(S) = 8$$

Event A :

$$\text{Two Consecutive tails} = \{HTT, TTH, TTT\}$$

$$n(A) = 3$$

$$P(A) = \frac{n(A)}{n(S)} = \frac{3}{8}$$

17. What is the probability that a leap year selected at random will contain 53 Saturdays.

Solution:

A leap year has 366 days.

So it has 52 full weeks and 2 days.

52 Saturdays must be in 52 full weeks.

$$S = \{(\text{Sun} - \text{Mon}, \text{Mon} - \text{Tue}, \text{Tue} - \text{Wed}, \text{Wed} - \text{Thu}, \text{Thu} - \text{Fri}, \text{Fri} - \text{Sat}, \text{Sat} - \text{Sun})\}$$

$$n(S) = 7$$

Let A be the event of getting 53rd Saturday.

$$\text{Then } A = \{\text{Fri} - \text{Sat}, \text{Sat} - \text{Sun}\} \quad n(A) = 2$$

Probability of getting 53 Saturdays in a leap

$$\text{year is } P(A) = \frac{n(A)}{n(S)} = \frac{2}{7}$$

18. A die is rolled and a coin is tossed simultaneously. Find the probability that the die shows an odd number and the coin shows a head. SEP-21

Solution:

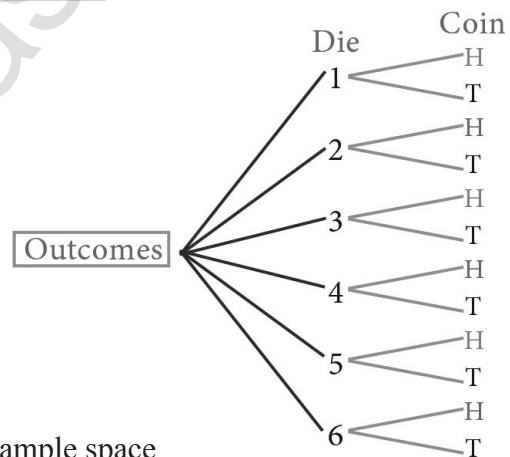

Sample space

$$S = \{1H, 1T, 2H, 2T, 3H, 3T, 4H, 4T, 5H, 5T, 6H, 6T\};$$

$$n(S) = 12$$

Let A be the event of getting an odd number and a head.

$$A = \{1H, 3H, 5H\}; n(A) = 3$$

$$P(A) = \frac{n(A)}{n(S)} = \frac{3}{12} = \frac{1}{4}$$

19. If $P(A) = 0.37$, $P(B) = 0.42$, $P(A \cap B) = 0.09$ then find $P(A \cup B)$.

Solution:

$$P(A) = 0.37, P(B) = 0.42, P(A \cap B) = 0.09$$

$$P(A \cup B) = P(A) + P(B) - P(A \cap B)$$

$$P(A \cup B) = 0.37 + 0.42 - 0.09 = 0.7$$

21. If $P(A) = \frac{2}{3}$, $P(B) = \frac{2}{5}$, $P(A \cup B) = \frac{1}{3}$ then find $P(A \cap B)$.

Solution:

$$P(A) = \frac{2}{3}, P(B) = \frac{2}{5}, P(A \cup B) = \frac{1}{3}$$

$$\begin{aligned} P(A \cap B) &= P(A) + P(B) - P(A \cup B) \\ &= \frac{2}{3} + \frac{2}{5} - \frac{1}{3} \\ &= \frac{10+6-5}{15} \end{aligned}$$

$$P(A \cap B) = \frac{11}{15}$$

22. The probability that atleast one of A and B occur is 0.6. If A and B occur simultaneously with probability 0.2, then find $P(\bar{A}) + P(\bar{B})$.

Solution:

$$\text{Given } P(A \cup B) = 0.6, P(A \cap B) = 0.2$$

$$P(A \cup B) = P(A) + P(B) - P(A \cap B)$$

$$\begin{aligned} P(A) + P(B) &= P(A \cup B) + P(A \cap B) \\ &= 0.6 + 0.2 \\ &= 0.8 \end{aligned}$$

$$\begin{aligned} \therefore P(\bar{A}) + P(\bar{B}) &= 1 - P(A) + 1 - P(B) \\ &= 2 - [P(A) + P(B)] \\ &= 2 - 0.8 \\ &= 1.2 \end{aligned}$$

5 Marks

1. Find the mean and variance of the first n natural numbers.

Solution:

$$\text{Mean } \bar{x} = \frac{\text{Sum of all the observations}}{\text{Number of observations}}$$

$$\begin{aligned} &= \frac{\sum x_i}{n} = \frac{1+2+3+\dots+n}{n} = \frac{n(n+1)}{2 \times n} \\ \bar{x} &= \frac{n+1}{2} \end{aligned}$$

$$\text{Variance } \sigma^2$$

$$\begin{aligned} &= \frac{\sum x_i^2}{n} - \left(\frac{\sum x_i}{n} \right)^2 \left| \begin{aligned} \sum x_i^2 &= 1^2 + 2^2 + 3^2 + \dots + n^2 \\ (\sum x_i)^2 &= (1+2+3+\dots+n)^2 \end{aligned} \right. \\ &= \frac{n(n+1)(2n+1)}{6 \times n} - \left| \frac{n(n+1)}{2 \times n} \right|^2 \\ &= \frac{n+1}{2} \left[\frac{2n+1}{3} - \frac{n+1}{2} \right] \\ &= \frac{n+1}{2} \left[\frac{4n+2-3n-3}{6} \right] \end{aligned}$$

$$\text{Variance } \sigma^2 = \frac{n+1}{2} \left[\frac{n-1}{6} \right] = \frac{n^2-1}{12}$$

2. Two dice are rolled. Find the probability that the sum of outcomes is (i) equal to 4 (ii) greater than 10 (iii) less than 13 **SEP-21**

Solution:

When we roll two dice, the sample space is given by

$$\begin{aligned} S = \{ &(1, 1), (1, 2), (1, 3), (1, 4), (1, 5), (1, 6) \\ &(2, 1), (2, 2), (2, 3), (2, 4), (2, 5), (2, 6) \\ &(3, 1), (3, 2), (3, 3), (3, 4), (3, 5), (3, 6) \\ &(4, 1), (4, 2), (4, 3), (4, 4), (4, 5), (4, 6) \\ &(5, 1), (5, 2), (5, 3), (5, 4), (5, 5), (5, 6) \\ &(6, 1), (6, 2), (6, 3), (6, 4), (6, 5), (6, 6) \}; \end{aligned}$$

$$n(S) = 36$$

i) Let A be the event of getting the sum of outcome values equal to 4.

$$\text{Then } A = \{(1, 3), (2, 2), (3, 1)\}; n(A) = 3.$$

Probability of getting the sum of outcomes equal to 4 is

$$P(A) = \frac{n(A)}{n(S)} = \frac{3}{36} = \frac{1}{12}$$

ii) Let B be the event of getting the sum of outcome values greater than 10.

$$\text{Then } B = \{(5, 6), (6, 5), (6, 6)\}; n(B) = 3$$

Probability of getting the sum of outcomes greater than 10 is

$$P(B) = \frac{n(B)}{n(S)} = \frac{3}{36} = \frac{1}{12}$$

iii) Let C be the event of getting the sum of outcomes less than 13. Here all the outcomes have the sum value less than 13. Hence $C = S$.

$$\text{Therefore, } n(C) = n(S) = 36$$

Probability of getting the total value less than 13 is

$$P(C) = \frac{n(C)}{n(S)} = \frac{36}{36} = 1$$

3. Two dice are rolled together. Find the probability of getting a doublet or sum of faces as 4.

Solution:

$$n(S) = 36$$

When two dice are rolled together, there will be $6 \times 6 = 36$ outcomes.

Let S be the sample space. Then $n(S) = 36$

Let A be the event of getting a doublet and B be the event of getting face sum 4.

Then $A = \{(1,1), (2,2), (3,3), (4,4), (5,5), (6,6)\}$

$B = \{(1,3), (2,2), (3,1)\}$

$\therefore A \cap B = \{(2,2)\}$

Then, $n(A) = 6$, $n(B) = 3$, $n(A \cap B) = 1$

$$P(A) = \frac{n(A)}{n(S)} = \frac{6}{36}$$

$$P(B) = \frac{n(B)}{n(S)} = \frac{3}{36}$$

$$P(A \cap B) = \frac{n(A \cap B)}{n(S)} = \frac{1}{36}$$

$\therefore P(\text{getting a doublet or a total of 4}) = P(A \cup B)$

$$\begin{aligned} P(A \cup B) &= P(A) + P(B) - P(A \cap B) \\ &= \frac{6}{36} + \frac{3}{36} - \frac{1}{36} = \frac{8}{36} = \frac{2}{9} \end{aligned}$$

Hence, the required probability is $\frac{2}{9}$.

4. If A is an event of a random experiment such that $P(A) : P(\bar{A}) = 17:15$ and $n(S) = 640$ then find (i) $P(\bar{A})$ (ii) $n(A)$.

Solution:

Given $n(S) = 640$

$$\frac{P(A)}{P(\bar{A})} = \frac{17}{15}$$

$$\frac{1 - P(\bar{A})}{P(\bar{A})} = \frac{17}{15}$$

$$15[1 - P(\bar{A})] = 17P(\bar{A})$$

$$15 - 15P(\bar{A}) = 17P(\bar{A})$$

$$15 = 15P(\bar{A}) + 17P(\bar{A})$$

$$32P(\bar{A}) = 15$$

$$P(\bar{A}) = \frac{15}{32}$$

$$P(A) = 1 - P(\bar{A})$$

$$\begin{aligned} &= 1 - \frac{15}{32} \\ &= \frac{32 - 15}{32} = \frac{17}{32} \end{aligned}$$

$$P(A) = \frac{n(A)}{n(S)}$$

$$\frac{17}{32} = \frac{n(A)}{640}$$

$$n(A) = \frac{17 \times 640}{32}$$

$$n(A) = 340$$

5. Two unbiased dice are rolled once. Find the probability of getting

- (i) a doublet (equal numbers on both dice)
 (ii) the product as a prime number
 (iii) the sum as a prime number
 (iv) the sum as 1

SEP-20

Solution:

$n(S) = 36$

- i) A = Probability of getting Doublets
 (Equal numbers on both dice)

$A = \{(1,1), (2,2), (3,3), (4,4), (5,5), (6,6)\}$

$$n(A) = 6; P(A) = \frac{n(A)}{n(S)} = \frac{6}{36} = \frac{1}{6}$$

B = Probability of getting the product of the prime number

- ii) $B = \{(1,2), (1,3), (1,5), (2,1), (3,1), (5,1)\}$

$$n(B) = 6; P(B) = \frac{n(B)}{n(S)} = \frac{6}{36} = \frac{1}{6}$$

C = Probability of getting sum of the prime number.

- iii) $C = \{(1,1), (2,1), (1,2), (1,4), (4,1), (1,6), (6,1), (2,3), (2,5), (3,2), (3,4), (4,3), (5,2), (5,6), (6,5)\}$

$$n(C) = 14; P(C) = \frac{n(C)}{n(S)} = \frac{14}{36} = \frac{7}{18}$$

- iv) D = Probability of getting the sum as 1

$$n(D) = 0; P(D) = \frac{n(D)}{n(S)} = 0$$

6. Three fair coins are tossed together. Find the probability of getting

- (i) all heads
 (ii) atleast one tail
 (iii) atleast one head
 (iv) atleast two tails

Solution:

Possible Outcomes = {HHH, HHT, HTH, THH, TTT, TTH, THT, HTT}

No. of possible outcomes,

$$n(S) = 2 \times 2 \times 2 = 8$$

- i) A = Probability of getting all heads

$$A = \{HHH\} \quad n(A) = 1$$

$$P(A) = \frac{n(A)}{n(S)} = \frac{1}{8}$$

- ii) B = Probability of getting atleast one tail

$B = \{HHT, HTH, THH, TTT, TTH, THT, HTT\}$

$$n(B) = 7 \quad P(B) = \frac{n(B)}{n(S)} = \frac{7}{8}$$

iii) C = Probability of getting atleast one head.

$$C = \{TTT, TTH, THT, HTT\}$$

$$n(C) = 4 \quad P(C) = \frac{n(C)}{n(S)} = \frac{4}{8} = \frac{1}{2}$$

iv) D = Probability of getting atleast two tails.

$$D = \{TTH, THT, HTT, HHT, HTH, THH, HHH\}$$

$$n(D) = 7 \quad P(D) = \frac{n(D)}{n(S)} = \frac{7}{8}$$

7. A bag contains 5 red balls, 6 white balls, 7 green balls, 8 black balls. One ball is drawn at random from the bag. Find the probability that the ball drawn is

- white
- black or red
- not white
- neither white nor black

Solution:

$$S = \{5 \text{ Red, } 6 \text{ White, } 7 \text{ Green, } 8 \text{ Black}\}$$

$$n(S) = 26$$

i) A – probability of getting white balls

$$n(A) = 6; \quad P(A) = \frac{6}{26} = \frac{3}{13}$$

ii) B – Probability of getting black (or) red balls

$$n(B) = 8 + 5 = 13; \quad P(B) = \frac{13}{26} = \frac{1}{2}$$

iii) C – Probability of not getting white balls

$$n(C) = 20; \quad P(C) = \frac{20}{26} = \frac{10}{13}$$

iv) D – Probability of getting of neither white nor black

$$n(D) = 12; \quad P(D) = \frac{12}{26} = \frac{6}{13}$$

8. In a box there are 20 non-defective and some defective bulbs. If the probability that a bulb selected at random from the box found to be defective is $\frac{3}{8}$ then, find the number of defective bulbs.

Solution:

In a box there are 20 non – defective and x defective bulbs

$$n(S) = x + 20$$

Let A – probability of getting Defective Bulbs

$$n(A) = x$$

$$P(A) = \frac{n(A)}{n(S)} = \frac{x}{x + 20}$$

From Given data

$$\frac{x}{x + 20} = \frac{3}{8}$$

$$8x = 3x + 60$$

$$5x = 60$$

$$x = 12$$

∴ Number of defective bulbs = 12

9. Some boys are playing a game, in which the stone thrown by them landing in a circular region (given in the figure) is considered as win and landing other than the circular region is considered as loss. What is the probability to win the game? ($\pi = 3.14$)

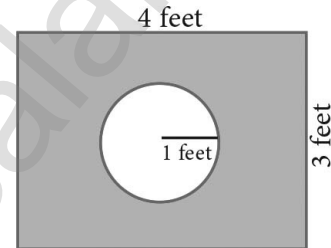

Solution:

$$\text{Total Region} = 4 \times 3 = 12 \text{ sq.ft}$$

$$\therefore n(S) = 12$$

$$\text{Winning Region} = \text{Area of circle}$$

$$= \pi r^2 = \pi(1)^2$$

$$= \pi = 3.14 \text{ sq. unit}$$

$$n(A) = 3.14$$

$$P(\text{Winning the Game}) = \frac{n(A)}{n(S)}$$

$$= \frac{3.14}{12} = \frac{314}{1200}$$

$$= \frac{157}{600}$$

10. The standard deviation and coefficient of variation of a data are 1.2 and 25.6 respectively. Find the value of mean.

Solution:

$$\sigma = 1.2, \quad CV = 25.6, \quad \bar{x} = ?$$

$$CV = \frac{\sigma}{\bar{x}} \times 100$$

$$\bar{x} = \frac{\sigma}{CV} \times 100 = \frac{1.2}{25.6} \times 100 = \frac{1200}{256}$$

$$\bar{x} = 4.7$$

11. Two customers Priya and Amuthan are visiting a particular shop in the same week (Monday to Saturday). Each is equally likely to visit the shop on any one day as on another day. What is the probability that both will visit the shop on

- (i) the same day
(ii) different days
(iii) consecutive days?

Solution:

$$n(S) = 36$$

i) A be the Probability of Priya and Amuthan to visit shop on same day

$$A = \{(\text{Mon, Mon}), (\text{Tue, Tue}), (\text{Wed, Wed}), (\text{Thurs, Thurs}), (\text{Fri, Fri}), (\text{Sat, Sat})\}$$

$$n(A) = 6$$

$$P(A) = \frac{n(A)}{n(S)} = \frac{6}{36} = \frac{1}{6}$$

ii) P (Priya and Amuthan Visit on Different Days)

$$= P(\bar{A}) = 1 - P(A) = 1 - \frac{1}{6} = \frac{5}{6}$$

iii) C be the Probability of Priya and Amuthan to visit on Consequent days

$$C = \{(\text{Mon, Tue}), (\text{Tue, Wed}), (\text{Wed, Thurs}), (\text{Thurs, Fri}), (\text{Fri, Sat}), (\text{Tue, Mon}), (\text{Wed, Tue}), (\text{Thurs, Wed}), (\text{Fri, Thurs}), (\text{Sat, Fri})\}$$

$$n(C) = 10$$

$$P(C) = \frac{n(C)}{n(S)} = \frac{10}{36} = \frac{5}{18}$$

12. In a game, the entry fee is ₹ 150. The game consists of tossing a coin 3 times. Dhana bought a ticket for entry. If one or two heads show, she gets her entry fee back. If she throws 3 heads, she receives double the entry fees. Otherwise she will lose. Find the probability that she (i) gets double entry fee (ii) just gets her entry fee (iii) loses the entry fee.

Solution:

$$S = \{HHH, HHT, HTH, THH, TTT, TTH, THT, HTT\}$$

$$n(S) = 8$$

i) For Receiving double entry Fees have to get Three Heads

$$A = \text{Probability of Getting three Heads}$$

$$A = \{HHH\}$$

$$n(A) = 1$$

$$P(A) = \frac{n(A)}{n(S)} = \frac{1}{8}$$

ii) For getting Entry Fess getting atleast one Head

$$B = \text{Probability of Getting One or Two Heads}$$

$$B = \{TTH, THT, HTT, HHT, HTH, THH\}$$

$$n(B) = 6$$

$$P(B) = \frac{n(B)}{n(S)} = \frac{6}{8} = \frac{3}{4}$$

iii) To loss the entry fees, she have to get no Heads

$$C = \text{Probability of Getting No Heads}$$

$$C = \{TTT\}$$

$$n(C) = 1$$

$$P(C) = \frac{n(C)}{n(S)} = \frac{1}{8}$$

13. If A and B are two events such that $P(A) = \frac{1}{4}$

$$P(B) = \frac{1}{2} \text{ and } P(A \text{ and } B) = \frac{1}{8}, \text{ find}$$

(i) P (A or B)

(ii) P(not A and not B).

Solution:

i. $P(A \text{ or } B) = P(A \cup B)$

$$= P(A) + P(B) - P(A \cap B)$$

$$P(A \text{ or } B) = \frac{1}{4} + \frac{1}{2} - \frac{1}{8} = \frac{5}{8}$$

ii. $P(\text{not } A \text{ and not } B) = P(\bar{A} \cap \bar{B})$

$$= P(\overline{A \cup B})$$

$$= 1 - P(A \cup B)$$

$$P(\text{not } A \text{ and not } B) = 1 - \frac{5}{8} = \frac{3}{8}$$

14. A card is drawn from a pack of 52 cards. Find the probability of getting a king or a heart or a red card.

Solution:

$$\text{Total number of cards} = 52 ; n(S) = 52.$$

Let A be the event of getting a king card.

$$n(A) = 4 ; P(A) = \frac{n(A)}{n(S)} = \frac{4}{52}$$

Let B be the event of getting a heart card

$$n(B) = 13 ; P(B) = \frac{n(B)}{n(S)} = \frac{13}{52}$$

Let C be the event of getting a red card

$$n(C) = 26; \quad P(C) = \frac{n(C)}{n(S)} = \frac{26}{52}$$

$$P(A \cap B) = P(\text{getting heart king}) = \frac{1}{52}$$

$$P(B \cap C) = P(\text{getting red and heart}) = \frac{13}{52}$$

$$P(A \cap C) = P(\text{getting red king}) = \frac{2}{52}$$

$$P(A \cap B \cap C) = P(\text{getting heart, king which is red}) = \frac{1}{52}$$

Therefore, required probability is

$$\begin{aligned} P(A \cup B \cup C) &= P(A) + P(B) + P(C) - P(A \cap B) - \\ &\quad P(B \cap C) - P(A \cap C) + P(A \cap B \cap C) \\ &= \frac{4}{52} + \frac{13}{52} + \frac{26}{52} - \frac{1}{52} - \frac{13}{52} - \frac{2}{52} + \frac{1}{52} \\ &= \frac{28}{52} = \frac{7}{13} \end{aligned}$$

15. In a class of 50 students, 28 opted for NCC, 30 opted for NSS and 18 opted both NCC and NSS. One of the students is selected at random. Find the probability that

- (i) The student opted for NCC but not NSS.
 (ii) The student opted for NSS but not NCC.
 (iii) The student opted for exactly one of them.

MAY-22

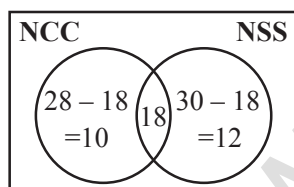

Solution:

Total number of students $n(S) = 50$

- i. A : A : opted only NCC but not NSS

$$P(A) = \frac{n(A)}{n(S)} = \frac{10}{50} = \frac{1}{5}$$

- ii. B : opted only NSS but not NCC

$$P(B) = \frac{n(B)}{n(S)} = \frac{12}{50} = \frac{6}{25}$$

- iii. C : opted only one

$$P(C) = \frac{n(C)}{n(S)} = \frac{(10+12)}{50} = \frac{22}{50} = \frac{11}{25}$$

16. Two dice are rolled once. Find the probability of getting an even number on the first die or a total of face sum 8.

Solution:

$$S = \{(1,1), (1,2), (1,3), (1,4), (1,5), (1,6), (2,1), (2,2), (2,3), (2,4), (2,5), (2,6), (3,1), (3,2), (3,3), (3,4), (3,5), (3,6), (4,1), (4,2), (4,3), (4,4), (4,5), (4,6), (5,1), (5,2), (5,3), (5,4), (5,5), (5,6), (6,1), (6,2), (6,3), (6,4), (6,5), (6,6)\}$$

$$n(S) = 36$$

A = Probability of getting an even number in the first die.

$$A = \{(2,1), (2,2), (2,3), (2,4), (2,5), (2,6), (4,1), (4,2), (4,3), (4,4), (4,5), (4,6), (6,1), (6,2), (6,3), (6,4), (6,5), (6,6)\}$$

$$n(A) = 18; \quad P(A) = \frac{n(A)}{n(S)} = \frac{18}{36}$$

B = Probability of getting a total face sum is 8

$$B = \{(2,6), (3,5), (4,4), (5,3), (6,2)\}$$

$$n(B) = 5; \quad P(B) = \frac{n(B)}{n(S)} = \frac{5}{36}$$

$$A \cap B = \{(2,6), (4,4), (6,2)\}$$

$$n(A \cap B) = 3$$

$$P(A \cap B) = \frac{3}{36}$$

$$\begin{aligned} P(A \cup B) &= P(A) + P(B) - P(A \cap B) \\ &= \frac{18}{36} + \frac{5}{36} - \frac{3}{36} \\ &= \frac{20}{36} = \frac{5}{9} \end{aligned}$$

17. A box contains cards numbered 3, 5, 7, 9, ... 35, 37. A card is drawn at random from the box. Find the probability that the drawn card have either multiples of 7 or a prime number.

Solution:

$$S = \{3, 5, 7, 9, 11, 13, 15, 17, 19, 21, 23, 25, 27, 29, 31, 33, 35, 37\}$$

$$n(S) = 18$$

Let A = Multiple of 7

$$A = \{7, 21, 35\}, \quad n(A) = 3$$

$$P(A) = \frac{3}{18}$$

Let B = a Prime number

$$B = \{3, 5, 7, 11, 13, 17, 19, 23, 29, 31, 37\}$$

$$n(B) = 11; P(B) = \frac{11}{18}$$

$$A \cap B = \{7\} \Rightarrow n(A \cap B) = 1$$

$$P(A \cap B) = \frac{1}{18}$$

$$P(\text{Either A or B}) = P(A \cup B)$$

$$= P(A) + P(B) - P(A \cap B)$$

$$= \frac{3}{18} + \frac{11}{18} - \frac{1}{18} = \frac{13}{18}$$

18. Three unbiased coins are tossed once. Find the probability of getting atmost 2 tails or atleast 2 heads.

Solution:

$$S = \{HHH, HHT, HTH, THH, TTT, TTH, THT, HTT\}$$

$$n(S) = 8$$

A = Probability of getting atmost 2 tails

$$A = \{HHH, HHT, HTH, THH, TTH, THT, HTT\}$$

$$n(A) = 7 \quad P(A) = \frac{7}{8}$$

B = Probability of getting atleast 2 heads

$$B = \{HHT, HTH, THH, HHH\}$$

$$n(B) = 4 \quad P(B) = \frac{4}{8}$$

$$P(A \cap B) = \frac{4}{8}$$

$$P(A \cup B) = P(A) + P(B) - P(A \cap B)$$

$$= \frac{7}{8} + \frac{4}{8} - \frac{4}{8} = \frac{7}{8}$$

19. A flower is selected at random from a basket containing 80 yellow, 70 red and 50 white flowers. Find the probability of selecting a yellow or red flower?

Solution:

Total number of flowers

$$n(S) = 80 + 70 + 50 = 200$$

No. of yellow flowers $n(Y) = 80$

$$\therefore P(Y) = \frac{n(Y)}{n(S)} = \frac{80}{200}$$

No. of red flowers $n(R) = 70$

$$\therefore P(R) = \frac{n(R)}{n(S)} = \frac{70}{200}$$

Y and R are mutually exclusive

$$P(Y \cup R) = P(Y) + P(R)$$

Probability of drawing either a yellow or red flower

$$P(Y \cup R) = \frac{80}{200} + \frac{70}{200} = \frac{150}{200} = \frac{3}{4}$$

20. In an apartment, in selecting a house from door numbers 1 to 100 randomly, find the probability of getting the door number of the house to be an even number or a perfect square number or a perfect cube number.

Solution:

Total number of houses $n(S) = 100$

Let A be the event of getting door number even.

$$A = \{2, 4, 6, 8, \dots, 100\}$$

$$n(A) = 50$$

$$\therefore P(A) = \frac{n(A)}{n(S)} = \frac{50}{100}$$

Let B be the event of getting door number perfect square

$$A = \{1, 4, 9, 16, 25, 36, 49, 64, 81, 100\}$$

$$n(A) = 10$$

$$\therefore P(A) = \frac{n(B)}{n(S)} = \frac{10}{100}$$

Let C be the event of getting door number perfect cube

$$A = \{1, 8, 27, 64\}$$

$$n(A) = 4$$

$$\therefore P(A) = \frac{n(C)}{n(S)} = \frac{4}{100}$$

$$P(A \cap B) = P$$

$$(\text{getting even perfect square number}) = \frac{5}{100}$$

$$P(B \cap C) = P$$

$$(\text{getting even perfect square and perfect cube number}) = \frac{2}{100}$$

$$P(A \cap C) = P$$

$$(\text{getting even perfect cube number}) = \frac{2}{100}$$

$$P(A \cap B \cap C) = P$$

$$(\text{getting even perfect square and perfect cube number}) = \frac{1}{100}$$

Required probability

$$P(A \cup B \cup C) = P(A) + P(B) + P(C) - P(A \cap B) - P(B \cap C) - P(A \cap C) + P(A \cap B \cap C)$$

$$= \frac{50}{100} + \frac{10}{100} + \frac{4}{100} - \frac{5}{100} - \frac{2}{100} - \frac{2}{100} + \frac{1}{100}$$

$$= \frac{65}{100} - \frac{9}{100} = \frac{56}{100} = \frac{14}{25}$$

1 MARK QUESTIONS

1. Relations and Functions

- If $n(A \times B) = 6$ and $A = \{1, 3\}$ then $n(B)$ is
A) 1 B) 2
C) 3 D) 6
- $A = \{a, b, p\}$, $B = \{2, 3\}$, $C = \{p, q, r, s\}$ then $n[(A \cup C) \times B]$ is
A) 8 B) 20
C) 12 D) 16
- If $A = \{1, 2\}$, $B = \{1, 2, 3, 4\}$, $C = \{5, 6\}$ and $D = \{5, 6, 7, 8\}$ then state which of the following statement is true.
A) $(A \times C) \subset (B \times D)$ B) $(B \times D) \subset (A \times C)$
C) $(A \times B) \subset (A \times D)$ D) $(D \times A) \subset (B \times A)$
- If there are 1024 relations from a set $A = \{1, 2, 3, 4, 5\}$ to a set B , then the number of elements in B is
A) 3 B) 2
C) 4 D) 8
- The range of the relation $R = \{(x, x^2) \mid x \text{ is a prime number less than } 13\}$ is
A) $\{2, 3, 5, 7\}$ B) $\{2, 3, 5, 7, 11\}$
C) $\{4, 9, 25, 49, 121\}$ D) $\{1, 4, 9, 25, 49, 121\}$
- If the ordered pairs $(a+2, 4)$ and $(5, 2a+b)$ are equal then (a, b) is
A) $(2, -2)$ B) $(5, 1)$
C) $(2, 3)$ D) $(3, -2)$
- Let $n(A) = m$ and $n(B) = n$ then the total number of non-empty relations that can be defined from A to B is
A) m^n B) n^m
C) $2^{mn} - 1$ D) 2^{mn}
- If $\{(a, 8), (6, b)\}$ represents an identity function, then the value of a and b are respectively
A) $(8, 6)$ B) $(8, 8)$
C) $(6, 8)$ D) $(6, 6)$
- Let $A = \{1, 2, 3, 4\}$ and $B = \{4, 8, 9, 10\}$. A function $f : A \rightarrow B$ given by $f = \{(1, 4), (2, 8), (3, 9), (4, 10)\}$ is a
A) Many-one function B) Identity function
C) One-to-one function D) Into function
- If $f(x) = 2x^2$ and $g(x) = \frac{1}{3x}$, then $f \circ g$ is
A) $\frac{3}{2x^2}$ B) $\frac{2}{3x^2}$
C) $\frac{2}{9x^2}$ D) $\frac{1}{6x^2}$
- If $f : A \rightarrow B$ is a bijective function and if $n(B) = 7$, then $n(A)$ is equal to
A) 7 B) 49
C) 1 D) 14
- Let f and g be two functions given by
 $f = \{(0, 1), (2, 0), (3, -4), (4, 2), (5, 7)\}$,
 $g = \{(0, 2), (1, 0), (2, 4), (-4, 2), (7, 0)\}$ then the range of $f \circ g$ is
A) $\{0, 2, 3, 4, 5\}$ B) $\{-4, 1, 0, 2, 7\}$
C) $\{1, 2, 3, 4, 5\}$ D) $\{0, 1, 2\}$
- Let $f(x) = \sqrt{1+x^2}$ then
A) $f(xy) = f(x).f(y)$ B) $f(xy)^3 \geq f(x).f(y)$
C) $f(xy) \leq f(x).f(y)$ D) None of these
- If $g = \{(1, 1), (2, 3), (3, 5), (4, 7)\}$ is a function given by $g(x) = \alpha x + \beta$ then the values of a and b are
A) $(-1, 2)$ B) $(2, -1)$
C) $(-1, -2)$ D) $(1, 2)$
- $f(x) = (x+1)^3 - (x-1)^3$ represents a function which is
A) linear B) cubic
C) reciprocal D) quadratic

2. Numbers and Sequences

- Euclid's division lemma states that for positive integers a and b , there exist unique integers q and r such that $a = bq + r$, where r must satisfy.
A) $1 < r < b$ B) $0 > r > b$
C) $0 \leq r < b$ D) $0 < r \leq b$
- Using Euclid's division lemma, if the cube of any positive integer is divided by 9 then the possible remainders are
A) 0, 1, 8 B) 1, 4, 8
C) 0, 1, 3 D) 1, 3, 5
- If the HCF of 65 and 117 is expressible in the form of $65m - 117$, then the value of m is
A) 4 B) 2
C) 1 D) 3

4. The sum of the exponents of the prime factors in the prime factorization of 1729 is
A) 1 B) 2
C) 3 D) 4
5. The least number that is divisible by all the numbers from 1 to 10 (both inclusive) is
A) 2025 B) 5220
C) 5025 D) 2520
6. $74k \equiv \underline{\hspace{2cm}} \pmod{100}$
A) 1 B) 2
C) 3 D) 4
7. Given $F_1 = 1, F_2 = 3$ and $F_n = F_{n-1} + F_{n-2}$ then F_5 is
A) 3 B) 5
C) 8 D) 11
8. The first term of an arithmetic progression is unity and the common difference is 4. Which of the following will be a term of this A.P.
A) 4551 B) 10091
C) 7881 D) 13531
9. If 6 times of 6th term of an A.P. is equal to 7 times the 7th term, then the 13th term of the A.P. is
A) 0 B) 6
C) 7 D) 13
10. An A.P. consists of 31 terms. If its 16th term is m , then the sum of all the terms of this A.P. is
A) $16m$ B) $62m$
C) $31m$ D) $\frac{31}{2}m$
11. In an A.P., the first term is 1 and the common difference is 4. How many terms of the A.P. must be taken for their sum to be equal to 120?
A) 6 B) 7
C) 8 D) 9
12. If $A = 2^{65}$ and $B = 2^{64} + 2^{63} + 2^{62} + \dots + 2^0$ which of the following is true?
A) B is 264 more than A
B) A and B are equal
C) B is larger than A by 1
D) A is larger than B by 1
13. The next term of the sequence 3
A) 124 B) 127
C) 23 D) 181
14. If the sequence t_1, t_2, t_3, \dots are in A.P. then the sequence $t_6, t_{12}, t_{18}, \dots$ is
A) a Geometric Progression
B) an Arithmetic Progression
C) neither an Arithmetic Progression nor a Geometric Progression
D) a constant sequence
15. The value of $(1^3 + 2^3 + 3^3 + \dots + 15^3) - (1 + 2 + 3 + \dots + 15)$ is
A) 14400 B) 14200
C) 14280 D) 14520

3. Algebra

1. A system of three linear equations in three variables is inconsistent if their planes
A) intersect only at a point
B) intersect in a line
C) coincides with each other
D) do not intersect
2. The solution of the system $x + y - 3z = -6, -7y + 7z = 7, 3z = 9$ is
A) $x = 1, y = 2, z = 3$ B) $x = -1, y = 2, z = 3$
C) $x = -1, y = -2, z = 3$ D) $x = 1, y = -2, z = 3$
3. If $(x - 6)$ is the HCF of $x^2 - 2x - 24$ and $x^2 - kx - 6$ then the value of k is
A) 3 B) 5
C) 6 D) 8
4. $\frac{3y - 3}{y} \div \frac{7y - 7}{3y^2}$ is
A) $\frac{9y}{7}$ B) $\frac{9y^3}{(21y - 21)}$
C) $\frac{21y^2 - 42y + 21}{3y^3}$ D) $\frac{7(y^2 - 2y + 1)}{y^2}$
5. $y^2 + \frac{1}{y^2}$ is not equal to
A) $\frac{y^4 + 1}{y^2}$ B) $\left(y + \frac{1}{y}\right)^2$
C) $\left(y - \frac{1}{y}\right)^2 + 2$ D) $\left(y + \frac{1}{y}\right)^2 - 2$

6. $\frac{x}{x^2 - 25} - \frac{8}{x^2 - 6x + 5}$ gives
- A) $\frac{x^2 - 7x + 40}{(x - 5)(x + 5)}$ B) $\frac{x^2 + 7x + 40}{(x - 5)(x + 5)(x + 1)}$
 C) $\frac{x^2 - 7x + 40}{(x^2 - 25)(x + 1)}$ D) $\frac{x^2 + 10}{(x^2 - 25)(x + 1)}$
7. The square root of $\frac{256x^8y^4z^{10}}{25x^6y^6z^6}$ is equal to
- A) $\frac{16}{5} \sqrt{\frac{x^2z^4}{y^2}}$ B) $16 \sqrt{\frac{y^2}{x^2z^4}}$
 C) $\frac{16}{5} \sqrt{\frac{y}{xz^2}}$ D) $\frac{16}{5} \sqrt{\frac{xz^2}{y}}$
8. Which of the following should be added to make $x^4 + 64$ a perfect square
- A) $4x^2$ B) $16x^2$
 C) $8x^2$ D) $-8x^2$
9. The solution of $(2x - 1)^2 = 9$ is equal to
- A) -1 B) 2
 C) -1, 2 D) None of these
10. The values of a and b if $4x^4 - 24x^3 + 76x^2 + ax + b$ is a perfect square are
- A) 100, 120 B) 10, 12
 C) -120, 100 D) 12, 10
11. If the roots of the equation $qx^2 + px + r = 0$ are the squares of the roots of the equation $qx^2 + px + r = 0$, then q, p, r are in _____
- A) A.P B) G.P
 C) Both A.P and G.P D) none of these
12. Graph of a linear equation is a _____.
- A) straight line B) circle
 C) parabola D) hyperbola
13. The number of points of intersection of the quadratic polynomial $x^2 + 4x + 4$ with the X-axis is
- A) 0 B) 1
 C) 0 or 1 D) 2
14. For the given matrix $A = \begin{pmatrix} 1 & 3 & 5 & 7 \\ 2 & 4 & 6 & 8 \\ 9 & 11 & 13 & 15 \end{pmatrix}$ the order of the matrix A^T is
- A) 2×3 B) 3×2
 C) 3×4 D) 4×3
15. If A is a 2×3 matrix and B is a 3×4 matrix, how many columns does AB have
- A) 3 B) 4
 C) 2 D) 5
16. If number of columns and rows are not equal in a matrix then it is said to be a
- A) diagonal matrix B) rectangular matrix
 C) square matrix D) identity matrix
17. Transpose of a column matrix is
- A) unit matrix B) diagonal matrix
 C) column matrix D) row matrix
18. Find the matrix X if $2X + \begin{pmatrix} 1 & 3 \\ 5 & 7 \end{pmatrix} = \begin{pmatrix} 5 & 7 \\ 9 & 5 \end{pmatrix}$
- A) $\begin{pmatrix} -2 & -2 \\ 2 & -1 \end{pmatrix}$ B) $\begin{pmatrix} 2 & 2 \\ 2 & -1 \end{pmatrix}$
 C) $\begin{pmatrix} 1 & 2 \\ 2 & 2 \end{pmatrix}$ D) $\begin{pmatrix} 2 & 1 \\ 2 & 2 \end{pmatrix}$
19. Which of the following can be calculated from the given matrices $A = \begin{pmatrix} 1 & 2 \\ 3 & 4 \\ 5 & 6 \end{pmatrix}$, $B = \begin{pmatrix} 1 & 2 & 3 \\ 4 & 5 & 6 \\ 7 & 8 & 9 \end{pmatrix}$
- (i) A^2 (ii) B^2
 (iii) AB (iv) BA
- A) (i) and (ii) only B) (ii) and (iii) only
 C) (ii) and (iv) only D) all of these
20. If $A = \begin{pmatrix} 1 & 2 & 3 \\ 3 & 2 & 1 \end{pmatrix}$, $B = \begin{pmatrix} 1 & 0 \\ 2 & -1 \\ 0 & 2 \end{pmatrix}$ and $C = \begin{pmatrix} 0 & 1 \\ -2 & 5 \end{pmatrix}$. Which of the following statements are correct?
- (i) $AB + C = \begin{pmatrix} 5 & 5 \\ 5 & 5 \end{pmatrix}$ (ii) $BC = \begin{pmatrix} 0 & 1 \\ 2 & -3 \\ -4 & 10 \end{pmatrix}$
 (iii) $BA + C = \begin{pmatrix} 2 & 5 \\ 3 & 0 \end{pmatrix}$ (iv) $(AB)C = \begin{pmatrix} -8 & 20 \\ -8 & 13 \end{pmatrix}$
- A) (i) and (ii) only B) (ii) and (iii) only
 C) (iii) and (iv) only D) all of these

4. Geometry

1. If in triangles ABC and EDF, $\frac{AB}{DE} = \frac{BC}{FD}$ then they will be similar, when

- A) $\angle B = \angle E$ B) $\angle A = \angle D$
 C) $\angle B = \angle D$ D) $\angle A = \angle F$

2. In $\triangle LMN$, $\angle L = 60^\circ$, $\angle M = 50^\circ$. If $\triangle LMN \sim \triangle PQR$ then the value of $\angle R$ is

- A) 40° B) 70°
 C) 30° D) 110°

3. If $\triangle ABC$ is an isosceles triangle with $\angle C = 90^\circ$ and $AC = 5$ cm, then AB is

- A) 2.5 cm B) 5 cm
 C) 10 cm D) $5\sqrt{2}$ cm

4. In a given figure $ST \parallel QR$, $PS = 2$ cm and $SQ = 3$ cm. Then the ratio of the area of $\triangle PQR$ to the area of $\triangle PST$ is

- A) 25 : 4
 B) 25 : 7
 C) 25 : 11
 D) 25 : 13

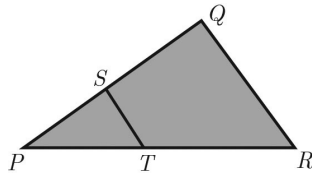

5. The perimeters of two similar triangles $\triangle ABC$ and $\triangle PQR$ are 36 cm and 24 cm respectively. If $PQ = 10$ cm, then the length of AB is

- A) $6\frac{2}{3}$ cm B) $\frac{10\sqrt{6}}{3}$ cm
 C) $66\frac{2}{3}$ cm D) 15 cm

6. If in $\triangle ABC$, $DE \parallel BC$. $AB = 3.6$ cm, $AC = 2.4$ cm and $AD = 2.1$ cm then the length of AE is

- A) 1.4 cm B) 1.8 cm
 C) 1.2 cm D) 1.05 cm

7. In a $\triangle ABC$, AD is the bisector of $\angle BAC$. If $AB = 8$ cm, $BD = 6$ cm and $DC = 3$ cm. The length of the side AC is

- A) 6 cm B) 4 cm
 C) 3 cm D) 8 cm

8. In the adjacent figure $\angle BAC = 90^\circ$ and $AD \perp BC$ then

- A) $BD \cdot CD = BC^2$
 B) $AB \cdot AC = BC^2$
 C) $BD \cdot CD = AD^2$
 D) $AB \cdot AC = AD^2$

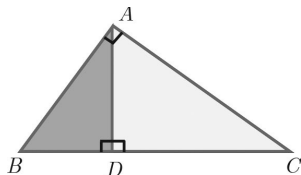

9. Two poles of heights 6 m and 11 m stand vertically on a plane ground. If the distance between their feet is 12 m, what is the distance between their tops?

- A) 13 m B) 14 m
 C) 15 m D) 12.8 m

10. In the given figure, $PR = 26$ cm, $QR = 24$ cm, $\angle PAQ = 90^\circ$, $PA = 6$ cm and $QA = 8$ cm. Find $\angle PQR$

- A) 80° B) 85°
 C) 75° D) 90°

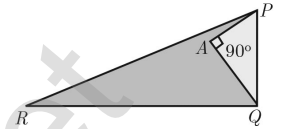

11. A tangent is perpendicular to the radius at the

- A) centre B) point of contact
 C) infinity D) chord

12. How many tangents can be drawn to the circle from an exterior point?

- A) one B) two
 C) infinite D) zero

13. The two tangents from an external points P to a circle with centre at O are PA and PB. If $\angle APB = 70^\circ$ then the value of $\angle AOB$ is

- A) 100° B) 110°
 C) 120° D) 130°

14. In figure CP and CQ are tangents to a circle with centre at O. ARB is another tangent touching the circle at R. If $CP = 11$ cm and $BC = 7$ cm, then the length of BR is

- A) 6 cm
 B) 5 cm
 C) 8 cm
 D) 4 cm

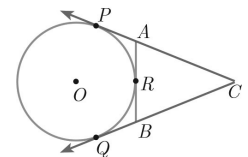

15. In figure if PR is tangent to the circle at P and O is the centre of the circle, then $\angle POQ$ is

- A) 120°
 B) 100°
 C) 110°
 D) 90°

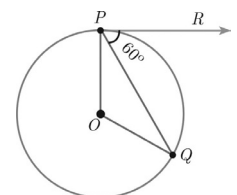

5. Coordinate Geometry

1. The area of triangle formed by the points $(-5, 0)$, $(0, -5)$ and $(5, 0)$ is
 A) 0 sq.units B) 25 sq.units
 C) 5 sq.units D) none of these
2. A man walks near a wall, such that the distance between him and the wall is 10 units. Consider the wall to be the Y axis. The path travelled by the man is
 A) $x = 10$ B) $y = 10$
 C) $x = 0$ D) $y = 0$
3. The straight line given by the equation $x = 11$ is
 A) parallel to X axis
 B) parallel to Y axis
 C) passing through the origin
 D) passing through the point $(0, 11)$
4. If $(5, 7)$, $(3, p)$ and $(6, 6)$ are collinear, then the value of p is
 A) 3 B) 6
 C) 9 D) 12
5. The point of intersection of $3x - y = 4$ and $x + y = 8$ is
 A) $(5, 3)$ B) $(2, 4)$
 C) $(3, 5)$ D) $(4, 4)$
6. The slope of the line joining $(12, 3)$, $(4, a)$ is $\frac{1}{8}$. The value of 'a' is
 A) 1 B) 4
 C) -5 D) 2
7. The slope of the line which is perpendicular to a line joining the points $(0, 0)$ and $(-8, 8)$ is
 A) -1 B) 1
 C) $\frac{1}{3}$ D) -8
8. If slope of the line PQ is $\frac{1}{\sqrt{3}}$ then slope of the perpendicular bisector of PQ is
 A) $\sqrt{3}$ B) $-\sqrt{3}$
 C) $\frac{1}{\sqrt{3}}$ D) 0
9. If A is a point on the Y axis whose ordinate is 8 and B is a point on the X axis whose abscissae is 5 then the equation of the line AB is
 A) $8x + 5y = 40$ B) $8x - 5y = 40$
 C) $x = 8$ D) $y = 5$
10. The equation of a line passing through the origin and perpendicular to the line $7x - 3y + 4 = 0$ is
 A) $7x - 3y + 4 = 0$ B) $3x - 7y + 4 = 0$
 C) $3x + 7y = 0$ D) $7x - 3y = 0$
11. Consider four straight lines
 (i) $l_1 : 3y = 4x + 5$; (ii) $l_2 : 4y = 3x - 1$
 (iii) $l_3 : 4y + 3x = 7$ (iv) $l_4 : 4x + 3y = 2$
 Which of the following statement is true?
 A) l_1 and l_2 are perpendicular
 B) l_1 and l_4 are parallel
 C) l_2 and l_4 are perpendicular
 D) l_2 and l_3 are parallel
12. A straight line has equation $8y = 4x + 21$. Which of the following is true?
 A) The slope is 0.5 and the y intercept is 2.6
 B) The slope is 5 and the y intercept is 1.6
 C) The slope is 0.5 and the y intercept is 1.6
 D) The slope is 5 and the y intercept is 2.6
13. When proving that a quadrilateral is a trapezium, it is necessary to show
 A) Two sides are parallel
 B) Two parallel and two non-parallel sides
 C) Opposite sides are parallel
 D) All sides are of equal length
14. When proving that a quadrilateral is a parallelogram by using slopes you must find
 A) The slopes of two sides
 B) The slopes of two pair of opposite sides
 C) The lengths of all sides
 D) Both the lengths and slopes of two sides
15. $(2, 1)$ is the point of intersection of two lines.
 A) $x - y - 3 = 0$; $3x - y - 7 = 0$
 B) $x + y = 3$; $3x + y = 7$
 C) $3x + y = 3$; $x + y = 7$
 D) $x + 3y - 3 = 0$; $x - y - 7 = 0$

6. Trigonometry

1. The value of $\sin^2\theta + \frac{1}{1 + \tan^2\theta}$ is equal to
 A) $\tan^2\theta$ B) 1
 C) $\cot^2\theta$ D) 0
2. $\tan\theta\operatorname{cosec}^2\theta - \tan\theta$ is equal to
 A) $\sec\theta$ B) $\cot 2\theta$
 C) $\sin\theta$ D) $\cot\theta$
3. If $(\sin\alpha + \operatorname{cosec}\alpha)^2 + (\cos\alpha + \sec\alpha)^2 = k + \tan^2\alpha + \cot^2\alpha$, then the value of k is equal to
 A) 9 B) 7
 C) 5 D) 3
4. If $\sin\theta + \cos\theta = a$ and $\sec\theta + \operatorname{cosec}\theta = b$, then the value of $b(a^2 - 1)$ is equal to
 A) $2a$ B) $3a$
 C) 0 D) $2ab$
5. If $5x = \sec\theta$ and $\frac{5}{x} = \tan\theta$, then $x^2 - \frac{1}{x^2}$ is equal to
 A) 25 B) $\frac{1}{25}$
 C) 5 D) 1
6. If $\sin\theta = \cos\theta$, then $2\tan^2\theta + \sin^2\theta - 1$ is equal to
 A) $\frac{-3}{2}$ B) $\frac{3}{2}$
 C) $\frac{2}{3}$ D) $\frac{-2}{3}$
7. If $x = a\tan\theta$ and $y = b\sec\theta$ then
 A) $\frac{y^2}{b^2} - \frac{x^2}{a^2} = 1$ B) $\frac{x^2}{a^2} - \frac{y^2}{b^2} = 1$
 C) $\frac{x^2}{a^2} + \frac{y^2}{b^2} = 1$ D) $\frac{x^2}{a^2} - \frac{y^2}{b^2} = 0$
8. $(1 + \tan\theta + \sec\theta)(1 + \cot\theta - \operatorname{cosec}\theta)$ is equal to
 A) 0 B) 1
 C) 2 D) -1
9. $a\cot\theta + b\operatorname{cosec}\theta = p$ and $b\cot\theta + a\operatorname{cosec}\theta = q$ then $p^2 - q^2$ is equal to
 A) $a^2 - b^2$ B) $b^2 - a^2$
 C) $a^2 + b^2$ D) $b - a$
10. If the ratio of the height of a tower and the length of its shadow is $\sqrt{3} : 1$, then the angle of elevation of the sun has measure
 A) 45° B) 30°
 C) 90° D) 60°
11. The electric pole subtends an angle of 30° at a point on the same level as its foot. At a second point 'b' metres above the first, the depression of the foot of the pole is 60° . The height of the pole (in metres) is equal to
 A) $\sqrt{3}b$ B) -
 C) $\frac{b}{2}$ D) $\frac{b}{\sqrt{3}}$
12. A tower is 60 m high. Its shadow is x metres shorter when the sun's altitude is 45° than when it has been 30° , then x is equal to
 A) 41.92 m B) 43.92 m
 C) 43 m D) 45.6 m
13. The angle of depression of the top and bottom of 20 m tall building from the top of a multistoried building are 30° and 60° respectively. The height of the multistoried building and the distance between two buildings (in metres) is
 A) 20, $10\sqrt{3}$ B) 30, $5\sqrt{3}$
 C) 20, 10 D) 30, $10\sqrt{3}$
14. Two persons are standing 'x' metres apart from each other and the height of the first person is double that of the other. If from the middle point of the line joining their feet an observer finds the angular elevations of their tops to be complementary, then the height of the shorter person (in metres) is
 A) $\sqrt{2}x$ B) $\frac{x}{2\sqrt{2}}$
 C) $\frac{x}{\sqrt{2}}$ D) $2x$
15. The angle of elevation of a cloud from a point h metres above a lake is β . The angle of depression of its reflection in the lake is 45° . The height of location of the cloud from the lake is
 A) $\frac{h(1 + \tan\beta)}{1 - \tan\beta}$ B) $\frac{h(1 - \tan\beta)}{1 + \tan\beta}$
 C) $h \tan(45^\circ - \beta)$ D) none of these

7. Mensuration

1. The curved surface area of a right circular cone of height 15 cm and base diameter 16 cm is
 - A) $60\pi \text{ cm}^2$
 - B) $68\pi \text{ cm}^2$
 - C) $120\pi \text{ cm}^2$
 - D) $136\pi \text{ cm}^2$
2. If two solid hemispheres of same base radius r units are joined together along their bases, then curved surface area of this new solid is
 - A) $4\pi r^2$ sq. units
 - B) $6\pi r^2$ sq. units
 - C) $3\pi r^2$ sq. units
 - D) $8\pi r^2$ sq. units
3. The height of a right circular cone whose radius is 5 cm and slant height is 13 cm will be
 - A) 12 cm
 - B) 10 cm
 - C) 13 cm
 - D) 5 cm
4. If the radius of the base of a right circular cylinder is halved keeping the same height, then the ratio of the volume of the cylinder thus obtained to the volume of original cylinder is
 - A) 1:2
 - B) 1:4
 - C) 1:6
 - D) 1:8
5. The total surface area of a cylinder whose radius is $\frac{1}{3}$ of its height is
 - A) $\frac{9\pi h^2}{8}$ sq.units
 - B) $24\pi h^2$ sq.units
 - C) $\frac{8\pi h^2}{9}$ sq.units
 - D) $\frac{56\pi h^2}{9}$ sq.units
6. In a hollow cylinder, the sum of the external and internal radii is 14 cm and the width is 4 cm. If its height is 20 cm, the volume of the material in it is
 - A) $5600\pi \text{ cm}^3$
 - B) $11200\pi \text{ cm}^3$
 - C) $56\pi \text{ cm}^3$
 - D) $3600\pi \text{ cm}^3$
7. If the radius of the base of a cone is tripled and the height is doubled then the volume is
 - A) made 6 times
 - B) made 18 times
 - C) made 12 times
 - D) unchanged
8. The total surface area of a hemi-sphere is how much times the square of its radius.
 - A) π
 - B) 4π
 - C) 3π
 - D) 2π
9. A solid sphere of radius x cm is melted and cast into a shape of a solid cone of same radius. The height of the cone is
 - A) $3x$ cm
 - B) x cm
 - C) $4x$ cm
 - D) $2x$ cm
10. A frustum of a right circular cone is of height 16 cm with radii of its ends as 8 cm and 20 cm. Then, the volume of the frustum is
 - A) $3328\pi \text{ cm}^3$
 - B) $3228\pi \text{ cm}^3$
 - C) $3240\pi \text{ cm}^3$
 - D) $3340\pi \text{ cm}^3$
11. A shuttle cock used for playing badminton has the shape of the combination of
 - A) a cylinder and a sphere
 - B) a hemisphere and a cone
 - C) a sphere and a cone
 - D) frustum of a cone and a hemisphere
12. A spherical ball of radius r_1 units is melted to make 8 new identical balls each of radius r_2 units. Then $r_1 : r_2$ is
 - A) 2:1
 - B) 1:2
 - C) 4:1
 - D) 1:4
13. The volume (in cm^3) of the greatest sphere that can be cut off from a cylindrical log of wood of base radius 1 cm and height 5 cm is
 - A) $\frac{4}{3}\pi$
 - B) $\frac{10}{3}\pi$
 - C) 5π
 - D) $\frac{20}{3}\pi$
14. The height and radius of the cone of which the frustum is a part are h_1 units and r_1 units respectively. Height of the frustum is h_2 units and radius of the smaller base is r_2 units. If $h_2 : h_1 = 1 : 2$ then $r_2 : r_1$ is
 - A) 1 : 3
 - B) 1 : 2
 - C) 2 : 1
 - D) 3 : 1
15. The ratio of the volumes of a cylinder, a cone and a sphere, if each has the same diameter and same height is
 - A) 1 : 2 : 3
 - B) 2 : 1 : 3
 - C) 1 : 3 : 2
 - D) 3 : 1 : 2

8. Statistics and Probability

- Which of the following is not a measure of dispersion?
 - Range
 - Standard deviation
 - Arithmetic mean
 - Variance
- The range of the data 8, 8, 8, 8, 8,, 8 is
 - 0
 - 1
 - 8
 - 3
- The sum of all deviations of the data from its mean is
 - Always positive
 - always negative
 - zero
 - non-zero integer
- The mean of 100 observations is 40 and their standard deviation is 3. The sum of squares of all deviations is
 - 40000
 - 160900
 - 160000
 - 30000
- Variance of first 20 natural numbers is
 - 32.25
 - 44.25
 - 33.25
 - 30
- The standard deviation of a data is 3. If each value is multiplied by 5 then the new variance is
 - 3
 - 15
 - 5
 - 225
- If the standard deviation of x, y, z is p then the standard deviation of $3x + 5, 3y + 5, 3z + 5$ is
 - $3p + 5$
 - $3p$
 - $p + 5$
 - $9p + 15$
- If the mean and coefficient of variation of a data are 4 and 87.5% then the standard deviation is
 - 3.5
 - 3
 - 4.5
 - 2.5
- Which of the following is incorrect?
 - $P(A) > 1$
 - $0 \leq P(A) \leq 1$
 - $P(\phi) = 0$
 - $P(A) + P(\bar{A}) = 1$
- The probability a red marble selected at random from a jar containing p red, q blue and r green marbles is
 - $\frac{q}{p+q+r}$
 - $\frac{p}{p+q+r}$
 - $\frac{p+q}{p+q+r}$
 - $\frac{p+r}{p+q+r}$
- A page is selected at random from a book. The probability that the digit at units place of the page number chosen is less than 7 is
 - $\frac{3}{10}$
 - $\frac{7}{10}$
 - $\frac{3}{9}$
 - $\frac{7}{9}$
- The probability of getting a job for a person is $\frac{x}{3}$. If the probability of not getting the job is $\frac{2}{3}$ then the value of x is
 - 2
 - 1
 - 3
 - 1.5
- Kamalam went to play a lucky draw contest. 135 tickets of the lucky draw were sold. If the probability of Kamalam winning is $\frac{1}{9}$, then the number of tickets bought by Kamalam is
 - 5
 - 10
 - 15
 - 20
- If a letter is chosen at random from the English alphabets $\{a, b, \dots, z\}$, then the probability that the letter chosen precedes x
 - $\frac{12}{13}$
 - $\frac{1}{13}$
 - $\frac{23}{26}$
 - $\frac{3}{26}$
- A purse contains 10 notes of ₹ 2000, 15 notes of ₹ 500, and 25 notes of ₹ 200. One note is drawn at random. What is the probability that the note is either a ₹ 500 note or ₹ 200 note?
 - $\frac{1}{5}$
 - $\frac{3}{10}$
 - $\frac{2}{3}$
 - $\frac{4}{5}$

ANSWERS**1. Relations and Functions**

1.C	2.C	3.A	4.B	5.C	6.D	7.C	8.A
9.C	10.C	11.A	12.D	13.C	14.B	15.D	

2. Numbers and Sequences

1.C	2.A	3.B	4.C	5.D	6.A	7.D	8.C
9.A	10.C	11.C	12.D	13.B	14.B	15.C	

3. Algebra

1.D	2.A	3.B	4.A	5.B	6.C	7.D	8.B
9.C	10.C	11.B	12.A	13.B	14.D	15.B	16.B
17.D	18.B	19.C	20.A				

4. Geometry

1.C	2.B	3.D	4.A	5.D	6.A	7.B	8.C
9.A	10.D	11.B	12.B	13.B	14.D	15.A	

5. Coordinate Geometry

1.B	2.A	3.B	4.C	5.C	6.D	7.B	8.B
9.A	10.C	11.C	12.A	13.B	14.B	15.B	

6. Trigonometry

1.B	2.D	3.B	4.A	5.B	6.B	7.A	8.C
9.B	10.D	11.B	12.B	13.D	14.B	15.A	

7. Mensuration

1.D	2.A	3.A	4.B	5.C	6.B	7.B	8.C
9.C	10.A	11.D	12.A	13.A	14.B	15.D	

8. Statistics and Probability

1.C	2.A	3.C	4.B	5.C	6.D	7.B	8.A
9.A	10.B	11.B	12.B	13.C	14.C	15.D	

Problems for Practice**GRAPH**

- Discuss the nature of solutions of the following quadratic equations.
 - $x^2 + x - 12 = 0$
 - $x^2 - 8x + 16 = 0$
 - $x^2 + 2x + 5 = 0$
- Draw the graph of $y = 2x^2$ and hence solve $2x^2 - x - 6 = 0$
- Draw the graph of $y = x^2 + 4x + 3$ and hence find the roots of $x^2 + x + 1 = 0$
- Draw the graph of $y = x^2 + x - 2$ and hence solve $x^2 + x - 2 = 0$.
- Draw the graph of $y = x^2 + x - 2$ and hence solve $x^2 + x - 2 = 0$.

- Graph the following quadratic equations and state their nature of solutions.
 - $x^2 - 9x + 20 = 0$
 - $x^2 - 4x + 4 = 0$
 - $x^2 + x + 7 = 0$
 - $x^2 - 9 = 0$
 - $x^2 - 6x + 9 = 0$
 - $(2x - 3)(x + 2) = 0$
- Draw the graph of $y = x^2 - 4$ and hence solve $x^2 - x - 12 = 0$
- Draw the graph of $y = x^2 + x$ and hence solve $x^2 + 1 = 0$
- Draw the graph of $y = x^2 + 3x + 2$ and use it to solve $x^2 + 2x + 1 = 0$
- Draw the graph of $y = x^2 + 3x - 4$ and hence use it to solve $x^2 + 3x - 4 = 0$
- Draw the graph of $y = x^2 - 5x - 6$ and hence solve $x^2 - 5x - 14 = 0$
- Draw the graph of $y = 2x^2 - 3x - 5$ and hence solve $2x^2 - 4x - 6 = 0$
- Draw the graph of $y = (x - 1)(x + 3)$ and hence solve $x^2 - x - 6 = 0$

GEOMETRY

- Construct a ΔPQR in which $PQ = 8$ cm, $R = 60^\circ$ and the median RG from R to PQ is 5.8 cm. Find the length of the altitude from R to PQ .
- Construct a triangle ΔPQR such that $QR = 5$ cm, $\angle P = 30^\circ$ and the altitude from P to QR is of length 4.2 cm.
- Draw a triangle ABC of base $BC = 8$ cm, $A = 60^\circ$ and the bisector of $\angle A$ meets BC at D such that $BD = 6$ cm.
- Construct a ΔPQR which the base $PQ = 4.5$ cm, $\angle R = 35^\circ$ and the median from R to PQ is 6 cm.
- Construct a ΔPQR in which $QR = 5$ cm, $P = 40^\circ$ and the median PG from P to QR is 4.4 cm. Find the length of the altitude from P to QR .
- Construct a ΔPQR such that $QR = 6.5$ cm, $P = 60^\circ$ and the altitude from P to QR is of length 4.5 cm.
- Construct a ΔABC such that $AB = 5.5$ cm, $C = 25^\circ$ and the altitude from C to AB is 4 cm.
- Draw a triangle ABC of base $BC = 5.6$ cm, $A = 40^\circ$ and the bisector of $\angle A$ meets BC at D such that $CD = 4$ cm.
- Draw ΔPQR such that $PQ = 6.8$ cm, vertical angle is 50° and the bisector of the vertical angle meets the base at D where $PD = 5.2$ cm.

1

Relations and Functions

2 Marks

STAGE 2

1. If $f(x) = 3x - 2$, $g(x) = 2x + k$ and if $f \circ g = g \circ f$, then find the value of k .

Solution:

$$\begin{aligned} f(x) &= 3x - 2 & g(x) &= 2x + k \\ f \circ g &= f[g(x)] & g \circ f &= g[f(x)] \\ &= f[2x + k] & g \circ f &= g[3x - 2] \\ &= 3(2x + k) - 2 & &= 2(3x - 2) + k \\ &= 6x + 3k - 2 & &= 6x - 4 + k \\ f \circ g &= g \circ f \Rightarrow 6x + 3k - 2 = 6x - 4 + k \\ \Rightarrow 3k - k &= -4 + 2 \Rightarrow 2k = -2 \Rightarrow k = -1 \end{aligned}$$

2. Find k if $f \circ f(k) = 5$ where $f(k) = 2k - 1$.

Solution:

$$\begin{aligned} f \circ f(k) &= 5 \\ f \circ (2k - 1) &= 5 \\ (2k - 1) \circ (2k - 1) &= 5 \\ 2(2k - 1) - 1 &= 5 \\ 4k - 2 &= 5 + 1 \\ 4k - 2 &= 6 \\ 4k &= 8 \\ k &= 2 \end{aligned}$$

3. Using the functions f and g given below, find $f \circ g$ and $g \circ f$. Check whether $f \circ g = g \circ f$.

(i) $f(x) = x - 6$, $g(x) = x^2$

(ii) $f(x) = \frac{2}{x}$, $g(x) = 2x^2 - 1$

(iii) $f(x) = \frac{x+6}{3}$, $g(x) = 3 - x$

(iv) $f(x) = 3 + x$, $g(x) = x - 4$

(v) $f(x) = 4x^2 - 1$, $g(x) = 1 + x$

Solution:

i. $f(x) = x - 6$, $g(x) = x^2$

$$(f \circ g)(x) = f(g(x)) = f(x^2) = x^2 - 6$$

$$\begin{aligned} (g \circ f)(x) &= g(f(x)) = g(x - 6) \\ &= (x - 6)^2 = x^2 - 12x + 36 \end{aligned}$$

 $\therefore f \circ g \neq g \circ f$

ii. $f(x) = \frac{2}{x}$, $g(x) = 2x^2 - 1$

$$(f \circ g)(x) = f(g(x)) = f(2x^2 - 1) = \frac{2}{2x^2 - 1}$$

$$(g \circ f)(x) = g(f(x))$$

$$= g\left(\frac{2}{x}\right) = 2\left(\frac{2}{x}\right)^2 - 1$$

$$= 2\left(\frac{4}{x^2} - 1\right) = \frac{8}{x^2} - 2$$

 $\therefore f \circ g \neq g \circ f$

iii. $f(x) = \frac{x+6}{3}$, $g(x) = 3 - x$

$$\begin{aligned} (f \circ g)(x) &= f(g(x)) = f(3 - x) = \frac{(3 - x) + 6}{3} \\ &= \frac{9 - x}{3} \end{aligned}$$

$$(g \circ f)(x) = g(f(x)) = g\left(\frac{x+6}{3}\right)$$

$$= 3 - \frac{x+6}{3} = \frac{9 - x - 3}{3} = \frac{6 - x}{3}$$

 $\therefore f \circ g \neq g \circ f$

iv. $f(x) = 3 + x$, $g(x) = x - 4$

$$\begin{aligned} (f \circ g)(x) &= f(g(x)) = f(x - 4) \\ &= 3 + (x - 4) = x - 1 \end{aligned}$$

$$\begin{aligned} (g \circ f)(x) &= g(f(x)) = g(3 + x) \\ &= 3 + x - 4 = x - 1 \end{aligned}$$

 $\therefore f \circ g = g \circ f$

v. $f(x) = 4x^2 - 1$, $g(x) = 1 + x$

$$\begin{aligned} (f \circ g)(x) &= f(g(x)) \\ &= f(1 + x) \\ &= 4(1 + x)^2 - 1 \\ &= 4x^2 + 8x + 3 \end{aligned}$$

$$\begin{aligned} (g \circ f)(x) &= g(f(x)) \\ &= g(4x^2 - 1) \\ &= 1 + 4x^2 - 1 \\ &= 4x^2 \end{aligned}$$

 $\therefore f \circ g \neq g \circ f$

4. Find the value of k , such that $f \circ g = g \circ f$

(i) $f(x) = 3x + 2$, $g(x) = 6x - k$

(ii) $f(x) = 2x - k$, $g(x) = 4x + 5$

Solution:

i) $f(x) = 3x + 2$, $g(x) = 6x - k$

$$(3x + 2) \circ (6x - k) = (6x - k) \circ (3x + 2)$$

$$3(6x - k) + 2 = 6(3x + 2) - k$$

$$18x - 3k + 2 = 18x + 12 - k$$

$$-3k + k = 12 - 2$$

$$-2k = 10$$

$$k = \frac{-10}{2}$$

$$k = -5$$

ii. $f(x) = 2x - k$ $g(x) = 4x + 5$

$$f \circ g = g \circ f$$

$$(2x - k) \circ (4x + 5) = (4x + 5) \circ (2x - k)$$

$$2(4x + 5) - k = 4(2x - k) + 5$$

$$8x + 10 - k = 8x - 4k + 5$$

$$-k + 4k = 5 - 10$$

$$3k = -5$$

$$k = \frac{-5}{3}$$

5. If $f(x) = 2x - 1$, $g(x) = \frac{x+1}{2}$, show that $f \circ g = g \circ f = x$

Solution:

$$\therefore f \circ g = (f \circ g)(x) = f(g(x))$$

$$f \circ g = g \circ f$$

$$(2x - 1) \circ \left(\frac{x+1}{2}\right) = \left(\frac{x+1}{2}\right) \circ (2x - 1)$$

$$2 = \left(\frac{x+1}{2}\right) - 1 = \frac{2x - 1 + 1}{2}$$

$$x + 1 - 1 = \frac{2x}{2}$$

$$x = x$$

$$\therefore f \circ g = g \circ f = x$$

6. If $f(x) = x^2 - 1$, $g(x) = x - 2$ find a, if $g \circ f(a) = 1$.

Solution:

$$g \circ f = 1$$

$$(x - 2) \circ (a^2 - 1) = 1$$

$$a^2 - 1 - 2 = 1$$

$$a^2 - 3 = 1$$

$$a^2 = 4$$

$$\therefore a = \pm 2$$

5 Marks

STAGE 2

1. If the function $f: \mathbb{R} \rightarrow \mathbb{R}$ is defined by

$$f(x) = \begin{cases} 2x + 7; & x < -2 \\ x^2 - 2; & -2 \leq x < 3 \\ 3x - 2; & x \geq 3 \end{cases}$$

then find the values of (i) $f(4)$ (ii) $f(-2)$

(iii) $f(4) + 2f(1)$ (iv) $\frac{f(1) - 3f(4)}{f(-3)}$

Solution:

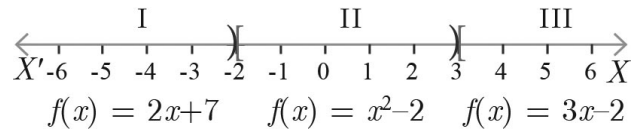

The function f is defined by three values in I, II, III as shown by the side

For a given value of $x = a$, find out the interval at which the point a is located, there after find $f(a)$ using the particular value defined in that interval.

- First, we see that, $x = 4$ lie in the third interval. Therefore, $f(x) = 3x - 2$;
 $f(4) = 3(4) - 2 = 10$
- $x = -2$ lies in the second interval. Therefore, $f(x) = x^2 - 2$;
 $f(-2) = (-2)^2 - 2 = 2$
- From (i), $f(4) = 10$. To find $f(1)$, first we see that, $x = 1$ lies in the second interval. Therefore, $f(x) = x^2 - 2 \Rightarrow f(1) = 1^2 - 2 = -1$
So, $f(4) + 2f(1) = 10 + 2(-1) = 8$
- We know that $f(1) = -1$ and $f(4) = 10$. Find finding $f(-3)$, we see that $x = -3$ lies in the first interval. Therefore, $f(x) = 2x + 7$,
thus $f(-3) = 2(-3) + 7 = 1$
Hence, $\frac{f(1) - 3f(4)}{f(-3)} = \frac{-1 - 3(10)}{1} = -31$

2. If the function f is defined by

$$f(x) = \begin{cases} x + 2; & x > 1 \\ 2; & -1 \leq x \leq 1 \\ x - 1 & -3 < x < -1 \end{cases}$$

find the values of

(i) $f(3)$ (ii) $f(0)$ (iii) $f(-1.5)$ (iv) $f(2) + f(-2)$

Solution:

i) $f(3) = x + 2 = 3 + 2 = 5$

ii) $f(0) = 2$

iii) $f(-1.5) = x - 1 = -1.5 - 1 = -2.5$

iv) $f(2) + f(-2)$
 $= [x+2] + [x-1]$
 $= [2+2] + [-2-1] = 4 + [-3] = 4 - 3 = 1$

3. A function $f: [-5, 9] \rightarrow \mathbb{R}$ is defined as follows:

$$f(x) = \begin{cases} 6x + 1; & -5 \leq x < 2 \\ 5x^2 - 1; & 2 \leq x < 6 \\ 3x - 4; & 6 \leq x \leq 9 \end{cases}$$

Find (i) $f(-3) + f(2)$ (ii) $f(7) - f(1)$

(iii) $2f(4) + f(8)$ (iv) $\frac{2f(-2) - f(6)}{f(4) + f(-2)}$

Solution:

i) $f(-3) + f(2)$

$$\begin{aligned} &= [6x + 1] + [5x^2 - 1] \\ &= [6(-3) + 1] + [5(2)^2 - 1] \\ &= [-18 + 1] + [5(4) - 1] = -17 + [20 - 1] \\ &= -17 + 19 = 2 \end{aligned}$$

ii) $f(7) - f(1)$

$$\begin{aligned} &= [3x - 4] - [6x + 1] \\ &= [3(7) - 4] - [6(1) + 1] \\ &= [21 - 4] - [6 + 1] = 17 - 7 = 10 \end{aligned}$$

iii) $2f(4) + f(8)$

$$\begin{aligned} &= 2[5x^2 - 1] + [3x - 4] \\ &= 2[5(4)^2 - 1] + [3(8) - 4] \\ &= 2[5(16) - 1] + [24 - 4] \\ &= 2[80 - 1] + [20] = 2[79] + 20 \\ &= 158 + 20 = 178 \end{aligned}$$

iv) $\frac{2f(-2) - f(6)}{f(4) + f(-2)}$

$$\begin{aligned} &= \frac{2[6x + 1] - [3x - 4]}{[5x^2 - 1] + [6x + 1]} \\ &= \frac{2[6(-2) + 1] - [3(6) - 4]}{[5(4)^2 - 1] + [6(-2) + 1]} \\ &= \frac{2[-12 + 1] - [18 - 4]}{[5(16) - 1] + [-12 + 1]} \\ &= \frac{2[-11] - [14]}{[80 - 1] + [-11]} \\ &= \frac{-22 - 14}{79 - 11} \\ &= \frac{-36}{68} = \frac{-9}{17} \end{aligned}$$

4. The distance S an object travels under the influence of gravity in time t seconds is given by $S(t) = \frac{1}{2}gt^2 + at + b$ where, (g is the acceleration due to gravity), a , b are constants. Verify whether the function $S(t)$ is one-one or not.

Solution:

$$s(t) = \frac{1}{2}gt^2 + at + b$$

Let t be 1, 2, 3,..... seconds

$$s(t_1) = s(t_2)$$

$$\frac{1}{2}gt_1^2 + at_1 + b = \frac{1}{2}gt_2^2 + at_2 + b$$

$$\frac{1}{2}gt_1^2 + at_1 + b - \frac{1}{2}gt_2^2 - at_2 - b = 0$$

$$\frac{1}{2}g(t_1^2 - t_2^2) + a(t_1 - t_2) = 0$$

$$\Rightarrow -g[(t_1 - t_2)(t_1 + t_2) + a(t_1 - t_2)] = 0$$

$$(t_1 - t_2) \left[\frac{1}{2}g(t_1 + t_2) + a \right] = 0$$

$$\Rightarrow t_1 - t_2 = 0$$

$$\left[\because \frac{1}{2}g[(t_1 + t_2) + a] \neq 0 \right]$$

$$t_1 = t_2$$

$\therefore s(t)$ it is one - one function

5. The function ' t ' which maps temperature in Celsius (C) into temperature in Fahrenheit (F) is defined by $t(C) = F$ where $F = \frac{9}{5}C + 32$.

Find, (i) $t(0)$ (ii) $t(28)$ (iii) $t(-10)$

(iv) the value of C when $t(C) = 212$

(v) the temperature when the Celsius value is equal to the Fahrenheit value.

Solution:

$$t(c) = F = \frac{9}{5}C + 32$$

i) $t(0) = \frac{9}{5}(0) + 32 = 32^\circ\text{F}$

ii) $t(28) = \frac{9}{5}(28) + 32 = 50.4 + 32 = 82.4^\circ\text{F}$

iii) $t(-10) = \frac{9}{5}(-10) + 32 = -18 + 32 = 14^\circ\text{F}$

iv) $t(c) = 212$

$$212 = \frac{9}{5}C + 32 \Rightarrow \frac{9}{5}C + 32 = 212$$

$$\frac{9}{5}C = 212 - 32 \Rightarrow \frac{9}{5}C = 180$$

$$\Rightarrow C = 180 \times \frac{5}{9} = 100^\circ\text{C}$$

v) Celsius Value = Fahrenheit Value

$$C = \frac{9}{5}C + 32 \Rightarrow 5C = 9C + 160$$

$$\Rightarrow 9C - 5C = -160 \Rightarrow 4C = -160;$$

$$\Rightarrow C = \frac{-160}{4} = -40^\circ$$

6. If $f(x) = 2x + 3$, $g(x) = 1 - 2x$ and $h(x) = 3x$.
Prove that $fo(goh) = (fog)oh$

Solution:

$$f(x) = 2x + 3, g(x) = 1 - 2x, h(x) = 3x$$

$$\begin{aligned} \text{Now, } (fog)(x) &= f(g(x)) \\ &= f(1 - 2x) = 2(1 - 2x) + 3 \\ &= 2 - 4x + 3 = 5 - 4x \end{aligned}$$

Then,

$$\begin{aligned} (fog) \circ h(x) &= (fog)(h(x)) = (fog)(3x) \\ &= 5 - 4(3x) \\ &= 5 - 12x \end{aligned} \quad \dots (1)$$

$$\begin{aligned} (goh)(x) &= g(h(x)) = g(3x) = 1 - 2(3x) \\ &= 1 - 6x \end{aligned}$$

So,

$$\begin{aligned} fo(goh)(x) &= f(1 - 6x) = 2(1 - 6x) + 3 \\ &= 2 - 12x + 3 = 5 - 12x \end{aligned} \quad \dots (2)$$

From (1) and (2),

we get $(fog)oh = fo(goh)$

Hence Proved.

7. Find x if $gff(x) = fgg(x)$, given $f(x) = 3x + 1$ and $g(x) = x + 3$.

Solution:

$$\begin{aligned} gff(x) &= g[f\{f(x)\}] = g[f(3x + 1)] \\ &= g[3(3x + 1) + 1] = g(9x + 4) \end{aligned}$$

$$g(9x + 4) = [(9x + 4) + 3] = 9x + 7$$

$$\begin{aligned} fgg(x) &= f[g\{g(x)\}] = f[g(x + 3)] \\ &= f[(x + 3) + 3] = f(x + 6) \end{aligned}$$

$$f(x + 6) = [3(x + 6) + 1] = 3x + 19$$

$$gff(x) = fgg(x)$$

Thus two quantities begin equal we get

$$9x + 7 = 3x + 19$$

$$9x - 3x = 12 \Rightarrow 6x = 12 \Rightarrow x = 3$$

8. Consider the functions $f(x)$, $g(x)$, $h(x)$ as given below. Show that

$(fog)oh = fo(goh)$ in each case.

(i) $f(x) = x - 1$, $g(x) = 3x + 1$ and $h(x) = x^2$

(ii) $f(x) = x^2$, $g(x) = 2x$ and $h(x) = x + 4$

(iii) $f(x) = x - 4$, $g(x) = x^2$ and $h(x) = 3x - 5$

Solution:

i.

$$\begin{aligned} (fog)oh &= fo(goh) \\ [(x-1) \circ (3x+1)] \circ x^2 &= (x-1) \circ [(3x+1) \circ x^2] \\ [3x+1-1] \circ x^2 &= (x-1) \circ [3x^2+1] \\ [3x] \circ x^2 &= 3x^2+1-1 \\ 3x^2 &= 3x^2 \\ (fog)oh &= fo(goh) \end{aligned}$$

Hence proved.

ii.

$$\begin{aligned} (fog)oh &= fo(goh) \\ [(x-4) \circ x^2] \circ (3x-5) &= (x-4) \circ [x^2 \circ (3x-5)] \\ [x^2-4] \circ [3x-5] &= (x-4) \circ [(3x-5)^2] \\ [3x-5]^2-4 &= [3x-5]^2-4 \\ [\because (a-b)^2 &= a^2-2ab+b^2] \\ (fog)oh &= fo(goh) \end{aligned}$$

Hence proved.

iii.

$$\begin{aligned} (fog)oh &= fo(goh) \\ [(x^2 \circ 2x) \circ (x+4)] &= (x^2 \circ [2x \circ (x+4)]) \\ [2x]^2 \circ (x+4) &= x^2 \circ [2(x+4)] \\ [2(x+4)]^2 &= [2(x+4)]^2 \\ (fog)oh &= fo(goh) \end{aligned}$$

Hence proved.

2

Numbers and Sequences

2 Marks

STAGE 2

1. If the Highest Common Factor of 210 and 55 is expressible in the form $55x - 325$, find x .

Solution:

Using Euclid's Division Algorithm, let us find the HCF of given numbers

$$210 = 55 \times 3 + 45$$

$$55 = 45 \times 1 + 10$$

$$45 = 10 \times 4 + 5$$

$$10 = 5 \times 2 + 0$$

Remainder = 0

So, the last divisor 5 is the Highest Common Factor.

Since, HCF is expressible in the form

$$55x - 325 = 5$$

gives $55x = 330$

Hence, $x = 6$

2. Use Euclid's Division Algorithm to find the Highest Common Factor (HCF) of
(i) 340 and 412 (ii) 867 and 255
(iii) 10224 and 9648

Solution:

By Euclid's Division Algorithm

$$a = bq + r$$

- i) To find HCF of 340 and 412

$$412 = 340(1) + 72$$

$$340 = 72(4) + 52$$

$$72 = 52(1) + 20$$

$$52 = 20(2) + 12$$

$$20 = 12(1) + 8$$

$$12 = 8(1) + 4$$

$$8 = 4(2) + 0 \quad \text{Remainder 0}$$

The remainder is 0, when the last divisor is 4.

\therefore HCF of 340 and 412 is 4

- ii) To find HCF of 867 and 255

$$867 = 255(3) + 102$$

$$255 = 102(2) + 51$$

$$102 = 51(2) + 0 \quad \text{Remainder 0}$$

\therefore HCF of 340 and 412 is 51

- iii) To find HCF of 10224 and 9648

$$10224 = 9648(1) + 576$$

$$9648 = 576(16) + 432$$

$$576 = 432(1) + 144$$

$$432 = 144(3) + 0$$

\therefore HCF of 10224 and 9648 is 144

3. If d is the Highest Common Factor of 32 and 60, find x and y satisfying $d = 32x + 60y$.

Solution:

Applying Euclid's Division Lemma,

$$a = bq + r$$

$$60 = 32 \times 1 + 28$$

$$\Rightarrow 32 = 28 \times 1 + 4$$

$$28 = 4 \times 7 + 0$$

\therefore H.C.F. of 32 and 60 is 4

That is $d = 4$. $d = 32x + 60y$

$$\Rightarrow 4 = 32x + 60y$$

$$4 = 32(2) + 60(-1)$$

$$\Rightarrow \therefore x = 2, y = -1$$

4. Find the remainders when 70004 and 778 is divided by 7.

Solution:

Since 70000 is divisible by 7

$$70000 \equiv 0 \pmod{7}$$

$$70000 + 4 \equiv 0 + 4 \pmod{7}$$

$$70004 \equiv 4 \pmod{7}$$

Therefore, the remainder when 70004 is divided by 7 is 4

\therefore 777 is divisible by 7

$$777 \equiv 0 \pmod{7}$$

$$777 + 1 \equiv 0 + 1 \pmod{7}$$

$$778 \equiv 1 \pmod{7}$$

Therefore, the remainder when 778 is divisible by 7 is 1.

5. Determine the value of d such that $15 \equiv 3 \pmod{d}$

Solution:

$$15 \equiv 3 \pmod{d} \text{ means}$$

$$15 - 3 = kd, \text{ for some integer } k.$$

$12 = kd$ gives d divides 12.

The divisors of 12 are 1, 2, 3, 4, 6, 12.

But d should be larger than 3 and so the possible values for d are 4, 6, 12.

6. Find the least positive value of x such that
(i) $67 + x \equiv 1 \pmod{4}$ (ii) $98 \equiv (x + 4) \pmod{5}$

Solution:

- i) $67 + x \equiv 1 \pmod{4}$

$$67 + x - 1 = 4n$$

$$66 + x = 4n$$

$66 + x$ is a multiple of 4.

68 is the nearest multiple of 4 more than 66.

Therefore the least positive value of x is 2.

- ii) $98 \equiv (x + 4) \pmod{5}$

$$98 - (x + 4) = 5n, \text{ for some integer } n.$$

$$94 - x = 5n$$

$94 - x$ is a multiple of 5.

Therefore, the least positive value of x must be 4

$\therefore 94 - 4 = 90$ is the nearest multiple of 5 less than 94.

7. Solve $8x \equiv 1 \pmod{11}$

Solution:

$$8x - 1 = 11n$$

$$\Rightarrow 8x = 11n + 1$$

$$\Rightarrow x = \frac{11n + 1}{8}$$

$$n = 5 \Rightarrow x = 7$$

$$n = 13 \Rightarrow x = 18, \dots$$

8. Compute x , such that $10^4 \equiv x \pmod{19}$

Solution:

$$10^2 = 100 \equiv 5 \pmod{19}$$

$$10^1 = (10^2)^2 \equiv 5^2 \pmod{19}$$

$$10^4 = 25 \pmod{19}$$

$$10^4 = 6 \pmod{19} \text{ [since } 25 \equiv 6 \pmod{19}]$$

Therefore, $x = 6$

9. Find the number of integer solutions of $3x \equiv 1 \pmod{15}$.

Solution:

$3x \equiv 1 \pmod{15}$ can be written as

$$3x - 1 = 15k \text{ for some integer } k$$

$$3x = 15k + 1$$

$$x = \frac{15k + 1}{3}$$

$$x = 5k + \frac{1}{3}$$

Since $5k$ is an integer, $5k + \frac{1}{3}$ cannot be an integer.

So there is no integer solution.

10. Find the least positive value of x such that

(i) $71 \equiv x \pmod{8}$ (ii) $78 + x \equiv 3 \pmod{5}$

(iii) $89 \equiv (x + 3) \pmod{4}$

(iv) $96 \equiv \frac{x}{7} \pmod{5}$

(v) $5x \equiv 4 \pmod{6}$

Solution:

i) $71 \equiv x \pmod{8} \Rightarrow 71 - x = 8k$

$$\Rightarrow 64 + 7 - x = 8k$$

$$\therefore x = 7$$

ii) $78 + x \equiv 3 \pmod{5}$

$$\Rightarrow 78 + x - 3 = 5k$$

$$\Rightarrow 75 + x \text{ is multiple of } 5.$$

\therefore The least positive value of $x = 0$

iii) $89 \equiv (x + 3) \pmod{4}$.

$$\Rightarrow 89 - x - 3 = 4k$$

$$\Rightarrow 86 - x = 4k$$

$$\Rightarrow 86 - x \text{ is multiple of } 4 \therefore x = 2$$

iv) $96 \equiv \frac{x}{7} \pmod{5}$

$$96 - \frac{x}{7} = 5k$$

$$96 - \frac{x}{7} \text{ is multiple of } 5 \therefore x = 7$$

v) $5x \equiv 4 \pmod{6}$

$$5x - 4 = 6k$$

$$\text{put, } k = 1, \Rightarrow 5x - 4 = 6; x = 2$$

11. Solve: $5x \equiv 4 \pmod{6}$

Solution:

$$5x \equiv 4 \pmod{6}$$

$$5x - 4 = 6k$$

$$5x = 6k + 4$$

$$x = \frac{6k + 4}{5}, k = 1, 6, 11, \dots$$

$$\text{If } k = 1, x = \frac{6(1) + 4}{5} = \frac{6 + 4}{5} = \frac{10}{5} = 2$$

$$\text{If } k = 6, x = \frac{6(6)+4}{5} = \frac{36+4}{5} = \frac{40}{5} = 8$$

$$\text{If } k = 11, x = \frac{6(11)+4}{5} = \frac{66+4}{5} = \frac{70}{5} = 14$$

$$\therefore x = 2, 8, 14, \dots$$

12. Solve: $3x - 2 \equiv 0 \pmod{11}$

Solution:

$$3x - 2 \equiv 0 \pmod{11}$$

$$3x - 2 = 11k$$

$$3x = 11k + 2$$

$$x = \frac{11k+2}{3}, k = 2, 5, 8, \dots$$

$$\text{If } k = 2, x = \frac{11(2)+2}{3} = \frac{22+2}{3} = \frac{24}{3} = 8$$

$$\text{If } k = 5, x = \frac{11(5)+2}{3} = \frac{55+2}{3} = \frac{57}{3} = 19$$

$$\text{If } k = 8, x = \frac{11(8)+2}{3} = \frac{88+2}{3} = \frac{90}{3} = 30$$

$$\therefore x = 8, 19, 30, \dots$$

13. What is the time 100 hours after 7 a.m.?

Solution:

$$100 \equiv x \pmod{24}$$

$$100 - x = 24n$$

$$100 - x \text{ is a multiple of } 24 \text{ (} 100 - 4 = 96 \text{)}$$

$\therefore x$ must be 4.

$$\begin{aligned} \text{The time 100 hrs after 7 a.m. is} &= 7 + 4 \\ &= 11 \text{ a.m} \end{aligned}$$

14. What is the time 15 hours before 11 p.m.?

Solution:

$$11 \text{ P.M.} = 23 \text{ hours}$$

Before 15 hours

$$23 - 15 \equiv 8 \pmod{24}$$

\therefore The time 15 hours in the past was 8 p.m.

15. Today is Tuesday. My uncle will come after 45 days. In which day my uncle will be coming?

Solution:

Today is Tuesday, now use modulo 7.

$$\therefore \text{Week days} = 7$$

$$45 \equiv x \pmod{7}$$

$$45 - x = 7n$$

$45 - x$ is multiple of 7.

\therefore The least Positive value of x is 3

The required day:

Tuesday + 3 days in Friday.

16. Prove that $2^n + 6 \times 9^n$ is always divisible by 7 for any positive integer n .

Solution:

$$9 \equiv 2 \pmod{7}$$

$$9^n \equiv 2^n \pmod{7}$$

$$6 \times 9^n = 6 \times 2^n \pmod{7}$$

$$2^n + 6 \times 9^n = 2^n + 6 \times 2^n \pmod{7}$$

$$= 2^n (1 + 6) \pmod{7}$$

$$2^n + 6 \times 9^n = (7) 2^n \pmod{7}$$

$\therefore 2^n + 6 \times 9^n$ is always divisible by 7 for any positive integer n

17. Find the remainder when 2^{81} is divided by 17.

Solution:

$$2^{81} \equiv (2^9)^9 \pmod{17} \quad \text{----- (1)}$$

$$2^9 \equiv 512 \pmod{17} \quad 0 \leq r < b$$

$$\therefore 2^9 \equiv 2 \pmod{17}$$

$$(1) \Rightarrow 2^{81} \equiv (2)^9 \pmod{17}$$

$$= 2 \pmod{17}$$

\therefore The remainder is 2

18. Find the first four terms of the sequences whose n th terms are given by

(i) $a_n = n^3 - 2$ (ii) $a_n = (-1)^{n+1}n(n+1)$

(iii) $a_n = 2n^2 - 6$

Solution:

i) $a_n = n^3 - 2$

$$a_1 = -1, a_2 = 6, a_3 = 25, a_4 = 62$$

ii) $a_n = (-1)^{n+1}n(n+1)$

$$a_1 = (-1)^2 \cdot 1(2) = 2$$

$$a_2 = (-1)^3 \cdot 2(3) = -6$$

$$a_3 = (-1)^4 \cdot 3(4) = 12$$

$$a_4 = (-1)^5 \cdot 4(5) = -20$$

\therefore The first terms are 2, -6, 12, -20

iii) $a_n = 2n^2 - 6$

$$a_1 = 2(1) - 6 = -4, a_2 = 2(4) - 6 = 2$$

$$a_3 = 2(9) - 6 = 12, a_4 = 2(16) - 6 = 26$$

\therefore The first terms are -4, 2, 12, 26

19. Find the n th term of the following sequences

(i) 2, 5, 10, 17, ... (ii) $0, \frac{1}{2}, \frac{2}{3}, \dots$

(iii) 3, 8, 13, 18, ...

Solution:

i) 2, 5, 10, 17, ...

$$\Rightarrow 1 + 1, 4 + 1, 9 + 1, 16 + 1$$

$$\therefore a_n = n^2 + 1, n \in \mathbb{N}$$

$$\text{ii) } 0, \frac{1}{2}, \frac{2}{3}, \dots$$

$$\Rightarrow \frac{1-1}{1}, \frac{2-1}{2}, \frac{3-1}{3}, \dots \therefore a_n = \frac{n-1}{n}, n \in \mathbb{N}$$

$$\text{iii) } 3, 8, 13, 18, \dots$$

$$\Rightarrow 5-2, 10-2, 15-2, 20-2, \dots$$

$$\Rightarrow 5(1) - 2, 5(2) - 2, 5(3) - 2, 5(4) - 2, \dots$$

$$\therefore a_n = 5n - 2, n \in \mathbb{N}.$$

20. First term a and common difference d are given below. Find the corresponding A.P.

(i) a = 5, d = 6 (ii) a = 7, d = -5

(iii) a = $\frac{3}{4}$, d = -

Solution:

Given a = 5, d = 6. General Form of A.P $\Rightarrow a, a + d, a + 2d, \dots \Rightarrow 5, 11, 17, 23, \dots$

Given a = 7, d = -5. General Form of A.P $\Rightarrow a, a + d, a + 2d, \dots \Rightarrow 7, 2, -3, -8, \dots$

Given a = $\frac{3}{4}$, d = $\frac{1}{2}$ General Form of A.P

$$\Rightarrow a, a + d, a + 2d, \dots \Rightarrow \frac{3}{4}, \frac{5}{4}, \frac{7}{4}, \frac{9}{4}, \dots$$

21. Find the first term and common difference of the Arithmetic Progressions whose n^{th} terms are given below

(i) $t_n = -3 + 2n$ (ii) $t_n = 4 - 7n$

Solution:

i) $t_n = -3 + 2n$

$$t_1 = -3 + 2(1) = -1,$$

$$t_2 = -3 + 2(2) = 1$$

$$\therefore a = -1, d = t_2 - t_1 = 1 + 1 = 2$$

ii) $t_n = 4 - 7n$

$$t_1 = 4 - 7(1) = -3$$

$$t_2 = 4 - 7(2) = -10$$

$$t_1 = -3, t_2 = -10$$

$$d = t_2 - t_1 = -7$$

$$\therefore a = -3, d = -7$$

22. Find the sum of the following:

(i) 3, 7, 11, ... up to 40 terms.

(ii) 102, 97, 92, ... up to 27 terms.

(iii) 6 + 13 + 20 + ... + 97

Solution:

i) a = 3, d = 4, n = 40

$$S_n = \frac{n}{2} [2a + (n-1)d]$$

$$S_{40} = \frac{40}{2} [2(3) + 39(4)]$$

$$= 20 [6 + 156]$$

$$= 20[162]$$

$$= 3240$$

ii) a = 102, d = -5, n = 27

$$S_n = \frac{n}{2} [2a + (n-1)d]$$

$$S_{27} = \frac{27}{2} [2(102) + 26(-5)]$$

$$= \frac{27}{2} [204 - 130] = \frac{27}{2} [74]$$

$$= 27 \times 37 = 999$$

iii) a = 6, d = 7, l = 97

$$n = \left(\frac{l-a}{d} \right) + 1 = \frac{97-6}{7} + 1 = 14$$

$$S_n = \frac{n}{2} [2a + (n-1)d]$$

$$S_{14} = \frac{14}{2} [2(6) + 13(7)] = \frac{14}{2} [12 + 91]$$

$$= 7 \times 103 = 721$$

23. How many consecutive odd integers beginning with 5 will sum to 480?

Solution:

$$5 + 7 + 9 + \dots n, S_n = 480.$$

Here a = 5, d = 2

$$S_n = \frac{n}{2} [2a + (n-1)d]$$

$$\Rightarrow \frac{n}{2} [2(5) + (n-1)2] = 480$$

$$\Rightarrow n(5 + n - 1) = 480$$

$$\Rightarrow n(4 + n) = 480$$

$$\Rightarrow n^2 + 4n - 480 = 0$$

$$\Rightarrow (n + 24)(n - 20) = 0$$

$$n = -24 \text{ (or) } n = 20$$

The required answer n = 20.

24. Find the sum of first 28 terms of an A.P. whose n^{th} term is $4n - 3$.

Solution:

Given in A.P. $t_n = 4n - 3$

$$\therefore a = t_1 = 4(1) - 3 = 1,$$

$$t_2 = 4(2) - 3 = 5$$

$$d = t_2 - t_1 = 5 - 1 = 4$$

$$l = t_{28} = 4(28) - 3 = 109$$

$$S_n = \frac{n}{2} [a + l]$$

$$\Rightarrow S_{28} = \frac{28}{2} [1 + 109] = 1540$$

25. The sum of first n terms of a certain series is given as $2n^2 - 3n$. Show that the series is an A.P.

Solution:

$$S_n = 2n^2 - 3n$$

$$S_1 = 2(1)^2 - 3(1) = 2 - 3 = -1,$$

$$S_2 = 2(2)^2 - 3(2) = 8 - 6 = 2,$$

$$S_3 = 2(3)^2 - 3(3) = 18 - 9 = 9;$$

$$t_1 = S_1 = -1$$

$$t_2 = S_2 - S_1 = 2 + 1 = 3$$

$$t_3 = S_3 - S_2 = 9 - 2 = 7$$

$$t_3 - t_2 = 4 \text{ and } t_2 - t_1 = 4. \quad t_3 - t_2 = t_2 - t_1$$

$$\therefore \text{The given series is an A.P.}$$

26. How many terms of the series $1 + 5 + 9 + \dots$ must be taken so that their sum is 190?

Solution:

Here we have to find the value of n , such that $S_n = 190$.

First term $a = 1$,

Common Difference $d = 5 - 1 = 4$.

Sum of first n terms of an A.P.

$$S_n = \frac{n}{2} [2a + (n-1)d] = 190$$

$$\frac{n}{2} [2 \times 1 + (n-1) \times 4] = 190$$

$$n [4n - 2] = 380$$

$$2n^2 - n - 190 = 0$$

But $n = 10$ as $n = -\frac{19}{2}$ is impossible.

$\therefore n = 10$.

27. The 104th term and 4th term of an A.P. are 125 and 0. Find the sum of first 35 terms.

Solution:

$$t_{104} = 125 \Rightarrow a + 103d = 125 \text{ -----(1)}$$

$$t_4 = 0 \Rightarrow a + 3d = 0 \text{ -----(2)}$$

$$(1) - (2) \Rightarrow 100d = 125$$

$$d = \frac{125}{100} = 1.25$$

To find S_{35} ,

$$(1) \Rightarrow a + 103(1.25) = 125$$

$$a + 128.75 = 125$$

$$a = -3.75$$

$$S_n = \frac{n}{2} [2a + (n-1)d]$$

$$S_{35} = \frac{35}{2} [2(-3.75) + (34)1.25]$$

$$= \frac{35}{2} [-7.50 + 42.50]$$

$$= \frac{35}{2} [35] = \frac{1225}{2} = 612.5$$

28. Find the 10th term of a G.P. whose 8th term is 768 and the common ratio is 2.

Solution:

$$\text{Given } t_8 = 768 \Rightarrow ar^7 = 768, r = 2$$

To find t_{10} .

$$t_{10} = ar^9 = ar^7 \times r^2 = 768 \times 4 = 3072$$

29. If a, b, c are in A.P. then show that $3^a, 3^b, 3^c$ are in G.P.

Solution:

If a, b, c are in A.P.

$$t_2 - t_1 = t_3 - t_2$$

$$b - a = c - b$$

$$2b = a + c \rightarrow (1)$$

$3^a, 3^b, 3^c$ are in G.P.

If a, b, c are in G.P.

$$\frac{t_2}{t_1} = \frac{t_3}{t_2}$$

$$\frac{b}{a} = \frac{c}{b} \Rightarrow b^2 = ac$$

$$(3^b)^2 = 3^a \cdot 3^c \Rightarrow 3^{2b} = 3^{a+c}$$

$$2b = a + c \rightarrow (2)$$

From (1) and (2) it is proved. $\therefore 3^a, 3^b, 3^c$ are in G.P.

30. Find the sum of 8 terms of the G.P.

$1, -3, 9, -27, \dots$

Solution:

Here $a = 1$,

Common ratio, $r = \frac{-3}{1} = -3 < 1, n=8$.

Sum of n terms of a G.P. is

$$S_n = \frac{a(r^n - 1)}{r - 1}, r \neq 1$$

$$\text{Hence, } S_8 = \frac{1((-3)^8 - 1)}{(-3) - 1} = \frac{6561 - 1}{-4}$$

$$= \frac{6560}{-4} = -1640$$

31. How many terms of the series $1 + 4 + 16 + \dots$ make the sum 1365?

Solution:

Let n be the number of terms to be added to get the sum 1365

$$a = 1, r = \frac{4}{1} = 4 > 1$$

$$S_n = 1365 \Rightarrow \frac{a(r^n - 1)}{r - 1} = 1365$$

$$\frac{1(4^n - 1)}{4 - 1} = 1365$$

$$(4^n - 1) = 4095$$

$$4^n = 4096$$

$$\Rightarrow 4^n = 4^6$$

$$n = 6$$

32. Find the sum $3 + 1 + \frac{1}{3} + \dots \infty$

Solution:

$$\text{Here } a = 3, r = \frac{t_2}{t_1} = \frac{1}{3}$$

$$\text{Sum of infinite terms, } S_\infty = \frac{a}{1-r} = \frac{3}{1-\frac{1}{3}} = \frac{9}{2}$$

33. Find the sum of first six terms of the G.P. 5, 15, 45, ...

Solution:

$$\text{G.P. } \Rightarrow 5, 15, 45, \dots$$

$$\text{Here, } a = 5, r = \frac{15}{5} = 3, n = 6$$

$$\therefore S_n = \frac{a(r^n - 1)}{r - 1}$$

$$S_6 = \frac{5(3^6 - 1)}{2} = \frac{5(729 - 1)}{2} = \frac{5(728)}{2}$$

$$= 5 \times 364$$

$$S_6 = 1820$$

34. Find the first term of the G.P. whose common ratio 5 and whose sum to first 6 terms is 46872.

Solution:

$$\text{Given in G.P. } \Rightarrow r = 5, n = 6, S_n = 46872.$$

$$\text{To find } a, \frac{a(r^n - 1)}{r - 1} = S_n$$

$$\Rightarrow \frac{a(5^6 - 1)}{5 - 1} = 46872$$

$$\Rightarrow a \left[\frac{15624}{4} \right] = a[3906] = 46872$$

$$\Rightarrow a = \frac{46872}{3906}$$

$$a = 12$$

35. Find the sum to infinity of

(i) $9 + 3 + 1 + \dots$ (ii) $21 + 14 + \frac{28}{3} + \dots$

Solution:

i) $9 + 3 + 1 + \dots$ Here, $a = 9, r = 1/3$

$$(\because -1 < r < 1)$$

$$S_\infty = \frac{a}{1-r} = \frac{9}{1-\frac{1}{3}} = \frac{27}{2}$$

ii) $21 + 14 + \frac{28}{3} + \dots$ Here, $a = 21, r = \frac{2}{3}$

$$(\because -1 < \frac{2}{3} < 1)$$

$$S_\infty = \frac{a}{1-r} = \frac{9}{1-\frac{2}{3}} = 63$$

5 Marks

STAGE 2

1. Find the HCF of 396, 504, 636.

Solution:

To find HCF of three given numbers, first we have to find HCF of the first two numbers.

To find HCF of 396 and 504.

Using Euclid's division algorithm we get

$$504 = 396 \times 1 + 108$$

The remainder is $108 \neq 0$

$$396 = 108 \times 3 + 72$$

The remainder is $72 \neq 0$

$$108 = 72 \times 1 + 36$$

The remainder is $36 \neq 0$

$$72 = 36 \times 2 + 0$$

The remainder is Zero.

Therefore HCF of 396, 504 = 36.

To find the HCF of 636 and 36.

Using Euclid's division algorithm we get

$$636 = 36 \times 17 + 24$$

The remainder is $24 \neq 0$

$$36 = 24 \times 1 + 12$$

The remainder is $12 \neq 0$

$$24 = 12 \times 2 + 0$$

The remainder is zero.

Therefore HCF of 636, 36 = 12.

Therefore, Highest Common Factor of

396, 504 and 636 is 12.

2. Use Euclid's Division Algorithm to find the Highest Common Factor (HCF) of 84, 90 and 120.

Solution:

To find HCF of 84, 90 and 120

First to find HCF of 84 and 90

$$90 = 84q + r \quad (6 \neq 0)$$

$$90 = 84 \times 1 + 6$$

$$84 = 6 \times 14 + 0$$

\therefore HCF of 84, 90 = 6.

Then to find HCF of 6 and 120

$$120 = 6 \times 20 + 0$$

\therefore HCF of 84, 90, 120 is 6

3. Find x, y and z, given that the numbers x, 10, y, 24, z are in A.P.

Solution:

A.P. $\Rightarrow x, 10, y, 24, z$

$$\text{That is } y = \frac{10+24}{2} = \frac{34}{2} = 17$$

\therefore A.P. = $x, 10, 17, 24, z$

Here we know that $d = 17 - 10 = 7$

$$\therefore x = 10 - 7 = 3$$

$$z = 24 + 7 = 31$$

$$\therefore x = 3, y = 17, z = 31.$$

4. Find the sum of all odd positive integers less than 450.

Solution:

The required answer = $1 + 3 + 5 + \dots + 449$

Here, $a = 1, d = 2, l = 449$

$$n = \left(\frac{l-a}{d} \right) + 1 = \frac{449-1}{2} + 1 = 225$$

$$\begin{aligned} \Rightarrow S_n &= \frac{225}{2} [1 + 449] \quad \because S_n = \frac{n}{2} [a+1] \\ &= 225 \times 225 \\ &= 50625 \end{aligned}$$

5. Find the first five terms of the following sequence $a_1=1, a_2=1, a_n = \frac{a_{n-1}}{a_{n-2}+3}; n \geq 3, n \in \mathbb{N}$

Solution:

The first two terms of this sequence are given by $a_1 = 1, a_2 = 1$. The third term a_3 depends on the first and second terms

$$\text{Given } a_n = \frac{a_{n-1}}{a_{n-2}+3}$$

$$a_3 = \frac{a_{3-1}}{a_{3-2}+3} = \frac{a_2}{a_1+3} = \frac{1}{1+3} = \frac{1}{4}$$

$$a_4 = \frac{a_{4-1}}{a_{4-2}+3} = \frac{a_3}{a_2+3} = \frac{\frac{1}{4}}{1+3} = \frac{\frac{1}{4}}{4} = \frac{1}{16}$$

$$\begin{aligned} &= \frac{1}{4} \times \frac{1}{4} = \frac{1}{16} \\ a_5 &= \frac{a_{5-1}}{a_{5-2}+3} = \frac{a_4}{a_3+3} = \frac{\frac{1}{16}}{\frac{1}{4}+3} = \frac{1}{16} \times \frac{4}{13} \\ &= \frac{1}{52} \end{aligned}$$

Therefore, the first five terms of the sequence are $1, 1, \frac{1}{4}, \frac{1}{16}, \frac{1}{52}$

6. The sum of first $n, 2n$ and $3n$ terms of an A.P. are $S_1, S_2,$ and S_3 respectively. Prove that $S_3 = 3(S_2 - S_1)$.

Solution:

If S_1, S_2 and S_3 are the sum of first $n, 2n$ and $3n$ terms of an A.P. respectively then

$$S_1 = \frac{n}{2} [2a+(n-1)d],$$

$$S_2 = \frac{2n}{2} [2a+(2n-1)d],$$

$$S_3 = \frac{3n}{2} [2a+(3n-1)d],$$

$$\begin{aligned} S_2 - S_1 &= \frac{2n}{2} [2a+(2n-1)d] - \frac{n}{2} [2a+(n-1)d] \\ &= \frac{n}{2} [[4a+2(2n-1)d] - [2a+(n-1)d]] \end{aligned}$$

$$S_2 - S_1 = \frac{n}{2} \times [2a+(3n-1)d]$$

$$3(S_2 - S_1) = \frac{3n}{2} [2a+(3n-1)d]$$

$$3(S_2 - S_1) = S_3$$

7. If $l^{\text{th}}, m^{\text{th}}$ and n^{th} terms of an A.P. are x, y, z respectively, then show that [May 22]

$$(i) x(m-n) + y(n-l) + z(l-m) = 0$$

$$(ii) (x-y)n + (y-z)l + (z-x)m = 0$$

Solution:

- i) Let a be the first term and d be the common difference. It is given that

$$t_1 = x, t_m = y, t_n = z$$

Using the general term formula

$$a + (l-1)d = x \quad \text{-----(1)}$$

$$a + (m-1)d = y \quad \text{-----(2)}$$

$$a + (n-1)d = z \quad \text{-----(3)}$$

$$\begin{aligned} x(m-n) + y(n-l) + z(l-m) &= [a+(l-1)d](m-n) + [a+(m-1)d](n-l) + [a+(n-1)d](l-m) \end{aligned}$$

$$= [a+l-d](m-n) + [a+md-d](n-l) + [a+nd-d][l-m]$$

$$\begin{aligned} &= am-an + lmd-lnd-md + nd + an-al + mnd - lmd - nd + ld + al-am+lnd-mnd-l+d+md \\ &= 0 \end{aligned}$$

- ii) On subtracting equation (2) from equation (1), equation (3) from equation (2) and equation (1) from equation (3), we get

$$x-y = (l-m)d; y-z = (m-n)d; z-x = (n-l)d$$

$$(x-y)n + (y-z)l + (z-x)m$$

$$= [(l-m)n + (m-n)l + (n-l)m]d$$

$$= [ln - mn + lm - nl + nm - lm]d = 0$$

8. A brick staircase has a total of 30 steps. The bottom step requires 100 bricks. Each

successive step requires two bricks less than the previous step.

(i) How many bricks are required for the top most step?

(ii) How many bricks are required to build the stair case?

Solution:

Given $100 + 98 + 96 + \dots$, $a = 100$,

$d = -2$, $n = 30$

i) To find t_{30}

$$t_n = a + (n - 1)d$$

$$t_{30} = 100 + 29(-2) = 100 - 58 = 42$$

ii) To find S_{30}

$$S_n = \frac{n}{2} [a + l] \quad S_{30} = \frac{30}{2} [100 + 42] = 2130$$

9. In a Geometric progression, the 4th term is

$$\frac{8}{9} \text{ and the 7th term is } \frac{64}{243}.$$

Find the Geometric Progression.

Solution:

$$4^{\text{th}} \text{ term } t_4 = \frac{8}{9} \Rightarrow ar^3 = \frac{8}{9} \quad \dots (1)$$

$$7^{\text{th}} \text{ term } t_7 = \frac{64}{243} \Rightarrow ar^6 = \frac{64}{243} \quad \dots (2)$$

Dividing (2) by (1)

$$\text{we get } \frac{ar^6}{ar^3} = \frac{\frac{64}{243}}{\frac{8}{9}} = \frac{64}{243} \times \frac{9}{8} = \frac{8}{27}$$

$$r^3 = \frac{8}{27} \Rightarrow r = \frac{2}{3}$$

Substituting the value of r in (1),

$$\text{we get, } a \times \left(\frac{2}{3}\right)^3 = \frac{8}{9} \Rightarrow a = 3$$

Therefore the Geometric Progression

a, ar, ar^2, \dots . That is, $3, 2, \frac{4}{3}, \dots$

10. The houses of a street are numbered from 1 to 49. Senthil's house is numbered such that the sum of numbers of the houses prior to Senthil's house is equal to the sum of numbers of the houses following Senthil's house. Find Senthil's house number?

Solution:

Let Senthil's house number be x .

$$1 + 2 + 3 + \dots + (x-1) = (x+1) + (x+2) + \dots + 49$$

$$1 + 2 + 3 + \dots + (x-1)$$

$$= [1 + 2 + 3 + \dots + 49] - [1 + 2 + 3 + \dots + x]$$

$$\frac{(x-1)}{2} [1+(x-1)] = \frac{49}{2} [1+49] - \frac{x}{2} [1+x]$$

$$\therefore S_n = \frac{n}{2} [a+l]$$

$$\frac{x(x-1)}{2} = \frac{49(50)}{2} - \frac{x(x+1)}{2}$$

$$x^2 - x = 2450 - x^2 - x$$

$$2x^2 = 2450$$

$$x^2 = 1225$$

$$x = 35$$

\therefore Senthil's house number = 35

11. The sum of three consecutive terms that are in A.P. is 27 and their product is 288. Find the three terms. SEP-21

Solution:

Let the 3 consecutive terms in an A.P. be $a-d, a, a+d$.

Sum of three terms

$$a-d + a + a+d = 27$$

$$3a = 27,$$

$$a = \frac{27}{3}$$

$$a = 9$$

Product of three terms

$$(a-d)(a)(a+d) = 288$$

$$a(a^2 - d^2) = 288$$

$$9(9^2 - d^2) = 288$$

$$81 - d^2 = \frac{288}{9}$$

$$81 - d^2 = 32$$

$$49 = d^2 \therefore d = \pm 7$$

\therefore The three terms of A.P. are

$$2, 9, 16 \text{ (or) } 16, 9, 2$$

12. The ratio of 6th and 8th term of an A.P. is 7:9. Find the ratio of 9th term to 13th term. MAY-22

Solution:

$$t_6 : t_8 = 7 : 9$$

$$\Rightarrow \frac{t_6}{t_8} = \frac{7}{9} \Rightarrow \frac{a+5d}{a+7d} = \frac{7}{9}$$

$$\Rightarrow 9a + 45d = 7a + 49d \Rightarrow a = 2d$$

To find $t_9 : t_{13}$

$$\Rightarrow \frac{t_9}{t_{13}} = \frac{a+8d}{a+12d} = \frac{10d}{14d} = \frac{5}{7}$$

The required ratio is 5 : 7.

13. Priya earned ₹15,000 in the first month. Thereafter her salary increased by ₹1500 per year. Her expenses are ₹13,000 during

the first year and the expenses increases by ₹900 per year. How long will it take for her to save ₹20,000 per month.

Solution:

	1 year	2 year
Income	₹15,000	₹16,500
Expenses	₹13,000	₹13,900
Savings	₹2,000	₹2,600

∴ Annual Savings ₹2,000, ₹2,600, ₹3,200...

Here $a = 2,000$, $d = 600$, $t_n = 20,000$

$$a + (n-1)d = 20,000$$

$$\Rightarrow 2000 + (n-1)600 = 20,000$$

$$\Rightarrow (n-1)600 = 20,000 - 2000 \\ = 18000$$

$$\Rightarrow n - 1 = \frac{18000}{600}$$

$$\Rightarrow n - 1 = 30$$

$$\Rightarrow n = 31 \text{ years}$$

The savings of Priya after 31 years is ₹ 20,000.

14. A mother divides ₹207 into three parts such that the amount are in A.P. and gives it to her three children. The product of the two least amounts that the children had ₹4623. Find the amount received by each child.

Solution:

Let the amount received by the three children be in the form of $a - d$, a , $a + d$.

Since, sum of the amount is ₹ 207

$$(a - d) + a + (a + d) = 207.$$

$$3a = 207 \Rightarrow a = 69$$

It is given that product of the two least amounts is 4623.

$$(a - d)a = 4623$$

$$(69 - d)69 = 4623;$$

$$69 - d = \frac{4623}{69} = 67$$

$$\therefore d = 2$$

Therefore, amount given by the mother to her three children are ₹(69 - 2), ₹69, ₹(69 + 2)

That is ₹67, ₹69 and ₹71.

15. Find the sum of all natural numbers between 300 and 600 which are divisible by 7.

Solution:

$$301 + 308 + 315 + \dots + 595 = ?$$

$$a = 300; d = 7; l = 595$$

$$n = \left(\frac{l - a}{d} \right) + 1$$

$$\begin{array}{r} 42 \\ 7 \overline{) 300} \\ \underline{28} \\ 20 \\ \underline{14} \\ 6 \end{array} \qquad \begin{array}{r} 8 \\ 7 \overline{) 600} \\ \underline{56} \\ 40 \\ \underline{35} \\ 5 \end{array}$$

$$a = 300 + 7 - 6 \qquad l = 600 - 5$$

$$a = 301 \qquad l = 595$$

$$n = \frac{595 - 300}{7} + 1 = \frac{294}{7} + 1$$

$$n = 42 + 1$$

$$n = 43$$

$$S_n = \frac{n}{2} (a + l)$$

$$S_{43} = \frac{43}{2} (301 + 595) = \frac{43}{2} (896) = 43 \times 448$$

$$S_{43} = 19264$$

16. Find the 15th, 24th and nth term (general term) of an A.P. given by 3, 15, 27, 39,...

Solution:

We have, first term = $a = 3$ and common difference = $d = 15 - 3 = 12$

We know that nth term (general term) of an A.P. with first term a and common difference d is given by $t_n = a + (n-1)d$

$$t_{15} = a + (15 - 1)d = a + 14d = 3 + 14(12) = 171$$

$$(Here a = 3 and d = 12)$$

$$t_{24} = a + (24 - 1)d = a + 23d = 3 + 23(12) = 279$$

The nth term (general term) is given by

$$t_n = a + (n - 1)d$$

$$t_n = 3 + (n - 1)12$$

$$t_n = 12n - 9$$

17. Determine the general term of an A.P. whose 7th term is -1 and 16th term is 17.

Solution:

Let the A.P. be $t_1, t_2, t_3, t_4, \dots$

It is given that $t_7 = -1$ and $t_{16} = 17$

$$a + (7 - 1)d = -1 \text{ and } a + (16 - 1)d = 17$$

$$a + 6d = -1 \quad \dots(1)$$

$$a + 15d = 17 \quad \dots(2)$$

subtracting equation (1) from equation (2),

$$\text{we get } 9d = 18 \Rightarrow d = 2.$$

putting $d = 2$ in equation (1),

$$\text{we get } a + 12 = -1. \Rightarrow a = -13$$

Hence, General term

$$t_n = a + (n-1)d$$

$$= -13 + (n-1)2 = 2n - 15$$

18. In an A.P., sum of four consecutive terms is 28 and their sum of their squares is 276. Find the four numbers.

Solution:

Let us take the four terms in the form $(a - 3d)$, $(a - d)$, $(a + d)$ and $(a + 3d)$
 Since, sum of the four terms is 28
 $a - 3d + a - d + a + d + a + 3d = 28$
 $4a = 28,$
 $a = 7$

Similarly, since sum of their squares is 276,
 $(a - 3d)^2 + (a - d)^2 + (a + d)^2 + (a + 3d)^2 = 276$
 $a^2 - 6ad + 9d^2 + a^2 - 2ad + d^2 + a^2 + 2ad + d^2 + a^2 + 6ad + 9d^2 = 276$
 $4a^2 + 20d^2 = 276 \Rightarrow 4(7)^2 + 20d^2 = 276$
 $4(49) + 20d^2 = 276 \Rightarrow 196 + 20d^2 = 276$
 $\Rightarrow 20d^2 = 80 \Rightarrow d^2 = 4 \Rightarrow d = \pm\sqrt{4}$ then $d = \pm 2$

If $d = 2$ then the four numbers for $7 - 3(2)$, $7 - 2$, $7 + 2$ and $7 + 3(2)$
 That is the four numbers are 1, 5, 9 and 13.
 If $a = 7$, $d = -2$ then
 the four numbers are 13, 9, 5 and 1
 \therefore The four consecutive terms of the A.P are 1, 5, 9 and 13.

19. Find the sum of $0.40 + 0.43 + 0.46 + \dots + 1$

Solution:

Here the value of n is not given. But the last term is given. From this, we can find the value of n . Given: $a = 0.40$ and $t_n = l = 1$,
 $d = 0.43 - 0.40 = 0.03$
 Therefore, $n = \left(\frac{l-a}{d}\right) + 1 = \left(\frac{1-0.40}{0.03}\right) + 1 = 21$
 Sum of first n terms of an A.P.

$$S_n = \frac{n}{2} [a+l]$$

Here, $n = 21$

$$\text{Therefore, } S_{21} = \frac{21}{2} [0.40+1] = 14.7$$

So, the sum of 21 terms of the given series is 14.7

20. If $S_1, S_2, S_3, \dots, S_m$ are the sums of n terms of m A.P.'s whose first terms are 1, 2, 3, ..., m and whose common differences are 1, 3, 5, ..., $(2m - 1)$ respectively, then

$$\text{show that } S_1 + S_2 + S_3 + \dots + S_m = \frac{1}{2} mn(mn+1)$$

Solution:

$$S_1 = \frac{n}{2} [2(1) + (n-1)1]$$

$$[\because S_n = \frac{n}{2} [2a + (n-1)d]]$$

$$S_2 = \frac{n}{2} [2(2) + (n-1)3]$$

$$S_3 = \frac{n}{2} [2(3) + (n-1)5]$$

.

.

$$S_m = \frac{n}{2} [2(m) + (n-1)(2m-1)]$$

$$S_1 + S_2 + S_3 + \dots + S_m$$

$$= \frac{n}{2} [2(1+2+3+\dots+m) + (n-1)(1+3+5+\dots+(2m-1))]$$

$$= \frac{n}{2} \left[2 \frac{m(m+1)}{2} + (n-1)m^2 \right]$$

$$= \frac{n}{2} [m^2 + m + m^2n - m^2] = \frac{n}{2} [m^2n + m]$$

$$= \frac{1}{2} mn[mn + 1]. \text{ Hence Proved.}$$

21. Find the sum

$$\left[\frac{a-b}{a+b} + \frac{3a-2b}{a+b} + \frac{5a-3b}{a+b} + \dots \text{to 12 terms} \right]$$

Solution:

From the given, have first term, $t_1 = \frac{a-b}{a+b}$

Common difference

$$d = \frac{3a-2b}{a+b} - \frac{a-b}{a+b} = \frac{2a-b}{a+b} \text{ and } n = 12$$

$$S_n = \frac{n}{2} [2a + (n-1)d]$$

$$S_{12} = \frac{12}{2} \left[2 \left(\frac{a-b}{a+b} \right) + 11 \left(\frac{2a-b}{a+b} \right) \right]$$

$$= 6 \times \left(\frac{2a-2b+22a-11b}{a+b} \right)$$

$$= \frac{6}{a+b} (24a - 13b)$$

22. The product of three consecutive terms of a Geometric Progression is 343 and their sum is $\frac{91}{3}$. Find the three terms.

Solution:

Since the product of 3 consecutive terms is given.

We can take them as $\frac{a}{r} \times a \times ar$.

Product of the terms = 343

$$a^3 = 7^3 \text{ gives } a = 7$$

$$\text{Sum of the terms} = \frac{91}{3}$$

$$\text{Hence, } a\left(\frac{1}{r} + 1 + r\right) = \frac{91}{3}$$

$$\text{gives } 7\left(\frac{1+r+r^2}{r}\right) = \frac{91}{3}$$

$$3 + 3r + 3r^2 = 13r \text{ gives } 3r^2 - 10r + 3 = 0$$

$$(3r-1)(r-3) = 0 \text{ gives } r = 3 \text{ or } r = \frac{1}{3}$$

If $a = 7, r = 3$ then the three terms are $\frac{7}{3}, 7, 21$

If $a = 7, r = \frac{1}{3}$ then the three terms are $21, 7, \frac{7}{3}$

23. Sivamani is attending an interview for a job and the company gave two offers to him. Offer A: ₹20,000 to start with followed by a guaranteed annual increase of 6% for the first 5 years. Offer B: ₹22,000 to start with followed by a guaranteed annual increase of 3% for the first 5 years. What is his salary in the 4th year with respect to the offers A and B?

Solution:

Offer A: $P = ₹ 20,000, r = 6\%, n = 3(4^{\text{th}} \text{ Year})$

$$\begin{aligned} A &= P\left(1 + \frac{r}{100}\right)^3 \\ &= 20,000\left(1 + \frac{6}{100}\right)^3 = 20,000\left(\frac{106}{100}\right)^3 \\ &= 20,000(1.06)^3 = ₹23,820 \end{aligned}$$

Offer B:

$P = ₹22,000 \quad r = 3\%$

$n = 3(4^{\text{th}} \text{ Year})$

$$\begin{aligned} A &= P\left(1 + \frac{r}{100}\right)^3 \\ &= 22,000\left(1 + \frac{3}{100}\right)^3 = 22,000\left(\frac{103}{100}\right)^3 \\ &= 22,000(1.03)^3 = ₹ 24,040 \end{aligned}$$

24. If a, b, c are three consecutive terms of an A.P. and x, y, z are three consecutive terms of a G.P. then prove that $xb - c \times yc - a \times za - b = 1$.

Solution:

a, b, c are three consecutive terms of an A.P.

Let $a = a, b = a + d, c = a + 2d$

x, y, z are three consecutive terms of an G.P.

$x = a, y = ar, z = ar^2$

$$\begin{aligned} \text{LHS} &= x^{b-c} \times y^{c-a} \times z^{a-b} \\ &= a^{a+d-a-2d} \times (ar)^{a+2d-a} \times (ar^2)^{a-a-d} \\ &= a^{-d} \times a^{2d} r^{2d} \times a^{-d} r^{-2d} \end{aligned}$$

$$= a^{-2d} \times a^{2d} \times r^{2d} \times r^{-2d}$$

$$= a^{-2d+2d} \times r^{2d-2d}$$

$$= a^0 \times r^0 = 1 \times 1 = 1$$

25. Find the least positive integer n such that $1 + 6 + 6^2 + \dots + 6^n > 5000$

Solution:

That is, to find the least value of n ,

such that $S_n > 5000$

$$\text{We have, } S_n = \frac{a(r^n - 1)}{r - 1} = \frac{1(6^n - 1)}{6 - 1} = \frac{6^n - 1}{5}$$

$$S_n > 5000 \Rightarrow \frac{6^n - 1}{5} > 5000$$

$$6^n - 1 > 25000 \Rightarrow 6^n > 25001$$

Since, $6^5 = 7776$ and $6^6 = 46656$

The least positive value of n is 6 such that

$$1 + 6 + 6^2 + \dots + 6^n > 5000.$$

26. A person saved money every year, half as much as he could in the previous year. If he had totally saved ₹ 7875 in 6 years then how much did he save in the first year?

Solution:

Total amount saved in 6 years is $S_6 = 7875$

Since he saved half as much money as every year he saved in the previous year,

We have, $r = \frac{1}{2} < 1$,

$$\frac{a(1 - r^n)}{1 - r} = \frac{a\left(1 - \left(\frac{1}{2}\right)^6\right)}{1 - \frac{1}{2}} = 7875$$

$$\frac{a\left(1 - \frac{1}{64}\right)}{1 - \frac{1}{2}} = 7875$$

$$\Rightarrow a \times \frac{63}{32} = 7875$$

$$\Rightarrow a = \frac{7875 \times 32}{63}$$

$$\Rightarrow a = 4000$$

The amount saved in the first year is ₹4000.

27. If $S_n = (x+y) + (x^2 + xy + y^2) + (x^3 + x^2y + xy^2 + y^3) + \dots$ n terms then prove

$$\text{that } (x-y)S_n = \frac{a(r^n - 1)}{r - 1}$$

Solution:

$$S_n = (x + y) + (x^2 + xy + y^2) + (x^3 + x^2y + xy^2 + y^3) + \dots n \text{ terms}$$

$$\begin{aligned}(x-y) S_n &= (x^2 - y^2) + (x^3 - y^3) + (x^4 - y^4) + \dots \\ &\quad \text{n terms} \\ &= (x^2 + x^3 + x^4 + \dots \text{ n terms}) \\ &\quad - (y^2 + y^3 + y^4 + \dots \text{ n terms}) \\ &= \left[\frac{x^2(x^n - 1)}{x-1} - \frac{y^2(y^n - 1)}{y-1} \right] \therefore S_n = \frac{a(r^n - 1)}{r-1}\end{aligned}$$

Hence the proof.

28. Find the sum of the series

$$(2^3 - 1^3) + (4^3 - 3^3) + (6^3 - 5^3) + \dots \text{ to}$$

(i) n terms (ii) 8 terms

Solution:

$$\begin{aligned}\text{i) } &(2^3 - 1^3) + (4^3 - 3^3) + (6^3 - 5^3) + \dots + (2n)^3 - (2n-1)^3 \\ &= \sum_1^n (2^3 + 4^3 + 6^3 + \dots) - \sum_1^n (1^3 + 3^3 + 5^3 + \dots) \\ &= \sum_1^n [(2n)^3 - (2n-1)^3] \\ &[\because a^3 - b^3 = (a-b)^3 + 3ab(a-b)] \\ &= \sum (2n - 2n + 1) + 3(2n)(2n-1)[2n-2n+1] \\ &= \sum_1^n [(1)^3 + 6n(2n-1)(1)] \\ &= \Sigma 1^3 + \Sigma 12n^2 - \Sigma 6n \\ &= \Sigma 1 + 12\Sigma n^2 - 6\Sigma n \\ &= n + 12 \left[\frac{n(n+1)(2n+1)}{6} \right] - 6 \left[\frac{n(n+1)}{2} \right] \\ &= n+2 [(n^2+n)(2n+1)] - 3[n(n+1)] \\ &= n+2 [2n^3+n^2+2n^2+n] - 3[n^2+n] \\ &= n+2[2n^3+3n^2+n] - 3n^2-3n \\ &= n+4n^3+6n^2+2n - 3n^2-3n \\ &= 4n^3 + 3n^2 = \text{sum of n terms}\end{aligned}$$

ii) When $n = 8$

$$\begin{aligned}\text{Sum of 8 terms} &= 4(8)^3 + 3(8)^2 \\ &= 4(512) + 3(64) \\ &= 2048 + 192 \\ &= 2240\end{aligned}$$

3

Algebra

2 Marks

STAGE 2

1. Solve: $2x - 3y = 6, x + y = 1$

Solution:

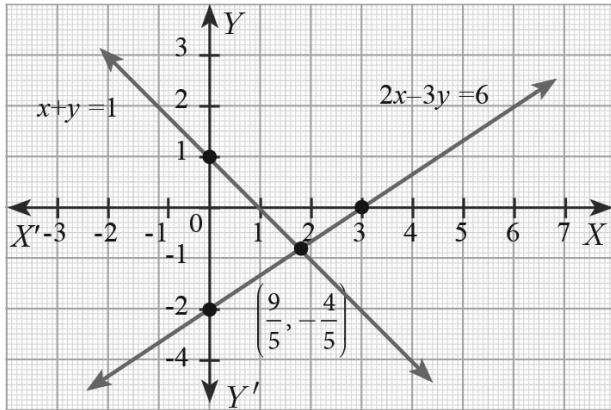

$$2x - 3y = 6 \quad \dots (1)$$

$$x + y = 1 \quad \dots (2)$$

$$(1) \times 1 \Rightarrow 2x - 3y = 6$$

$$(2) \times 3 \Rightarrow 3x + 3y = 3(+)$$

$$\underline{\hspace{1cm}}$$

$$5x = 9 \Rightarrow x = \frac{9}{5}$$

$$(2) \Rightarrow \frac{9}{5} + y = 1$$

$$y = 1 - \frac{9}{5}$$

$$y = \frac{5-9}{5} = \frac{-4}{5}$$

$$\text{Therefore, } x = \frac{9}{5}, y = \frac{-4}{5}$$

2. Find the LCM and GCD for the following and verify that $f(x) \times g(x) = \text{LCM} \times \text{GCD}$

(i) $21x^2y, 35xy^2$ (ii) $(x^3 - 1)(x + 1), (x^3 + 1)$ (iii) $(x^2y + xy^2), (x^2 + xy)$

Solution:

i) $21x^2y, 35xy^2$

$$f(x) = 21x^2y = 3 \times 7 \times x^2 \times y$$

$$g(x) = 35xy^2 = 5 \times 7 \times x \times y^2$$

$$\text{LCM} = 3 \times 5 \times 7 \times x^2 \times y^2 = 105x^2y^2$$

$$\text{GCD} = 7 \times x \times y = 7xy$$

$$f(x) \times g(x) = 3 \times 5 \times 72 \times x^3 \times y^3$$

$$\text{LCM} \times \text{GCD} = 3 \times 5 \times 72 \times x^3 \times y^3$$

$$\text{Hence, } f(x) \times g(x) = \text{LCM} \times \text{GCD}$$

ii) $(x^3 - 1)(x + 1), x^3 + 1$.

$$f(x) = (x^3 - 1)(x + 1)$$

$$= (x - 1)(x^2 + 1^2 + x \cdot 1)(x + 1)$$

$$= (x - 1)(x^2 + x + 1)(x + 1)$$

$$g(x) = x^3 + 1$$

$$= x^3 + 1^3 = (x + 1)(x^2 + 1^2 - x \cdot 1)$$

$$= (x + 1)(x^2 - x + 1)$$

$$\text{GCD} = (x + 1)$$

$$\text{LCM} = (x + 1)(x - 1)(x^2 + x + 1)(x^2 - x + 1)$$

$$f(x) \times g(x) = (x - 1)(x^2 + x + 1)(x + 1)(x + 1)(x^2 - x + 1)$$

$$\text{LCM} \times \text{GCD} = (x + 1)(x - 1)(x^2 + x + 1)(x^2 - x + 1)(x + 1)$$

$$\text{Hence, } f(x) \times g(x) = \text{LCM} \times \text{GCD}$$

(iii) $(x^2y + xy^2), (x^2 + xy)$

$$f(x) = (x^2y + xy^2) = xy(x + y)$$

$$g(x) = (x^2 + xy) = x(x + y)$$

$$\text{LCM} = xy(x + y)$$

$$\text{GCD} = x(x + y)$$

$$f(x) \times g(x) = x^2y(x + y)^2$$

$$\text{LCM} \times \text{GCD} = x^2y(x + y)^2$$

$$\text{Hence, } f(x) \times g(x) = \text{LCM} \times \text{GCD}$$

3. Find the LCM of each pair of the following polynomials

(i) $a^2 + 4a - 12, a^2 - 5a + 6$ whose GCD is $a - 2$ (ii) $x^4 - 27a^3x, (x - 3a)^2$ whose GCD is $(x - 3a)$

Solution:

i) $f(x) = a^2 + 4a - 12$

$$= (a + 6)(a - 2)$$

$$g(x) = a^2 - 5a + 6$$

$$= (a - 3)(a - 2)$$

$$\text{GCD} = a - 2$$

$$\text{LCM} = \frac{f(x) \times g(x)}{\text{GCD}}$$

$$= \frac{(a + 6)(a - 2) \times (a - 3)(a - 2)}{a - 2}$$

$$= (a + 6)(a - 3)(a - 2)$$

ii) $f(x) = x^4 - 27a^3x$

$$= x(x^3 - (3a)^3)$$

$$= (x)(x - 3a)(x^2 + 3xa + 9a^2)$$

$$g(x) = (x - 3a)^2$$

$$\text{LCM} = \frac{f(x) \times g(x)}{\text{GCD}}$$

$$= \frac{(x)(x-3a)(x^2+3xa+9a^2)(x-3a)^2}{x-3a}$$

$$\text{LCM} = (x)(x-3a)^2(x^2+3xa+9a^2)$$

4. Reduce each of the following rational expressions to its lowest form.

i) $\frac{x^2-1}{x^2+x}$ ii) $\frac{x^2-11x+18}{x^2-4x+4}$

iii) $\frac{9x^2-81x}{x^3-8x^2-9x}$ iv) $\frac{p^2-3p-40}{2p^3-24p^2-64p}$

Solution:

i) $\frac{x^2-1}{x^2+x} = \frac{x^2-1^2}{x(x+1)} = \frac{(x+1)(x-1)}{x(x+1)}$

$$= \frac{(x-1)}{x}$$

ii) $\frac{x^2-11x+18}{x^2-4x+4} = \frac{(x-9)(x-2)}{(x-2)(x-2)} = \frac{x-9}{x-2}$

iii) $\frac{9x^2+81x}{x^3-8x^2-9x} = \frac{9x(x+9)}{x(x^2+8x-9)}$

$$= \frac{9x(x+9)}{(x)(x+9)(x-1)} = \frac{9}{x-1}$$

iv) $\frac{p^2-3p-40}{2p^3-24p^2-64p} = \frac{(p-8)(p+5)}{2p(p-8)(p-4)}$

$$= \frac{(p+5)}{2p(p-4)}$$

5. (i) Multiply $\frac{x^3}{9y^2}$ by $\frac{27y}{x^5}$

(ii) Multiply $\frac{x^4b^2}{x-1}$ by $\frac{x^2-1}{a^4b^3}$

Solution:

i) $\frac{x^3}{9y^2} \times \frac{27y}{x^5} = \frac{27}{9yx^2} = \frac{3}{x^2y}$

ii) $\frac{x^4b^2}{x-1} \times \frac{x^2-1}{a^4b^3} = \frac{x^4}{x-1} \times \frac{(x+1)(x-1)}{a^4b^3}$

$$= \frac{x^4(x+1)}{a^4b^3}$$

6. Find

(i) $\frac{14x^4}{y} \div \frac{7x}{3y^4}$ ii) $\frac{x^2-16}{x+4} \div \frac{x-4}{x+4}$

iii) $\frac{16x^2-2x-3}{3x^2-2x-1} \div \frac{8x^2+11x+3}{3x^2-11x-4}$

Solution:

i) $\frac{14x^4}{y} \div \frac{7x}{3y^4} = \frac{14x^4}{y} \times \frac{3y^4}{7x} = 6x^3y^3$

ii) $\frac{x^2-16}{x+4} \div \frac{x-4}{x+4} = \frac{x^2-16}{x+4} \times \frac{x+4}{x-4}$

$$= \frac{(x+4)(x-4)}{x+4} \times \frac{x+4}{x-4} = x+4$$

iii) $\frac{16x^2-2x-3}{3x^2-2x-1} \div \frac{8x^2+11x+3}{3x^2-11x-4}$

$$= \frac{16x^2-2x-3}{3x^2-2x-1} \times \frac{3x^2-11x-4}{8x^2+11x+3}$$

$$= \frac{(8x+3)(2x-1)}{(3x+1)(x-1)} \times \frac{(3x+1)(x-4)}{(8x+3)(x+1)}$$

$$= \frac{(2x-1)(x-4)}{(x-1)(x+1)} = \frac{2x^2-9x+4}{x^2-1}$$

7. Subtract $\frac{1}{x^2+2}$ from $\frac{2x^3+x^2+3}{(x^2+2)^2}$

Solution:

$$\frac{2x^3+x^2+3}{(x^2+2)^2} - \frac{1}{x^2+2}$$

$$= \frac{2x^3+x^2+3-(x^2+2)}{(x^2+2)^2}$$

$$= \frac{2x^3+x^2+3-x^2-2}{(x^2+2)^2} = \frac{2x^3+1}{(x^2+2)^2}$$

8. Which rational expression should be subtracted from $\frac{x^2+6x+8}{3}$ to get $\frac{x^2-2x+4}{x^3+8}$

$$\frac{x^2-2x+4}{x^3+8}$$

Solution:

Required equation

$$= \frac{x^2+6x+8}{x^3+8} - \frac{3}{x^2-2x+4}$$

$$= \frac{(x+2)(x+4)}{x^3+2^3} - \frac{3}{x-2x+4}$$

$$= \frac{(x+2)(x+4)}{(x+2)(x^2-2x+4)} - \frac{3}{x^2-2x+4}$$

$$= \frac{(x+4)}{(x^2-2x+4)} - \frac{3}{x^2-2x+4}$$

$$= \frac{x+4-3}{x^2-2x+4} = \frac{x+1}{x^2-2x+4}$$

9. Solve: $2x^2 - 2\sqrt{6}x + 3 = 0$

Solution:

$$2x^2 - 2\sqrt{6}x + 3 = 0 = 2x^2 - \sqrt{6}x - \sqrt{6}x + 3$$

(by splitting the middle term)

$$= \sqrt{2}x(\sqrt{2}x - \sqrt{2}) - \sqrt{3}(\sqrt{2}x - \sqrt{3})$$

$$= (\sqrt{2}x - \sqrt{3})(\sqrt{2}x - \sqrt{3})$$

Now, equating the factors to zero we get,

$$(\sqrt{2}x - \sqrt{3})(\sqrt{2}x - \sqrt{3}) = 0$$

$$(\sqrt{2}x - \sqrt{3})^2 = 0$$

$$\sqrt{2}x - \sqrt{3} = 0$$

$$\therefore \text{The solution is } x = \frac{\sqrt{3}}{\sqrt{2}}$$

10. Solve: $2m^2 + 19m + 30 = 0$

Solution:

$$2m^2 + 19m + 30$$

$$= 2m^2 + 4m + 15m + 30$$

$$= 2m(m+2) + 15(m+2)$$

$$= (m+2)(2m+15)$$

Equating the factors to zero we get,

$$(m+2)(2m+15) = 0$$

$$m+2 = 0 \Rightarrow m = -2 \text{ or } 2m+15 = 0$$

$$\Rightarrow m = \frac{-15}{2}$$

$$\text{Therefore the roots are } -2 \text{ or } \frac{-15}{2}$$

11. Solve $x^4 - 13x^2 + 42 = 0$

Solution:

$$\text{Given : } x^4 - 13x^2 + 42 = 0$$

$$\text{Let } x^2 = y$$

$$y^2 - 13y + 42 = 0$$

$$y = 6 \text{ (or) } y = 7$$

$$x^2 = 6 \text{ (or) } x^2 = 7$$

$$\therefore x = \pm\sqrt{6} \text{ (or) } x = \pm\sqrt{7}$$

12. If the difference between a number and its reciprocal is $\frac{24}{5}$, find the number.

Solution:

Let x be the required number

$$\frac{1}{x} \text{ be its reciprocal}$$

$$\text{Given } x - \frac{1}{x} = \frac{24}{5}$$

$$\frac{x^2 - 1}{x} = \frac{24}{5}$$

$$5x^2 - 5 = 24x$$

$$5x^2 - 24x - 5 = 0$$

$$5x^2 - 25x + x - 5 = 0$$

$$x = 5, -\frac{1}{5}$$

13. Determine the nature of roots for the following quadratic equations

(i) $x^2 - x - 20 = 0$ (ii) $9x^2 - 24x + 16 = 0$

(iii) $2x^2 - 2x + 9 = 0$

Solution:

(i) $x^2 - x - 20 = 0$

$$\text{Here, } a = 1, b = -1, c = -20$$

$$\text{Now, } \Delta = b^2 - 4ac;$$

$$\Delta = (-1)^2 - 4(1)(-20) = 81$$

$$\text{Here } \Delta = 81 > 0.$$

So the equation will have real and unequal roots.

(ii) $9x^2 - 24x + 16 = 0$

$$\text{Here, } a = 9, b = -24, c = 16$$

$$\text{Now, } \Delta = b^2 - 4ac;$$

$$\Delta = (-24)^2 - 4(9)(-16) = 0$$

$$\text{Here } \Delta = 0.$$

So the equation will have real and equal roots.

(iii) $2x^2 - 2x + 9 = 0$

$$\text{Here, } a = 2, b = -2, c = 9$$

$$\text{Now, } \Delta = b^2 - 4ac;$$

$$\Delta = (-2)^2 - 4(2)(9) = -68$$

$$\Delta = -68 < 0.$$

So the equation will have no real roots.

14. i) Find the values of 'k', for which the quadratic equation

$$kx^2 - (8k + 4)x + 81 = 0 \text{ has real and equal roots?}$$

ii) Find the values of 'k' such that quadratic equation

$$(k + 9)x^2 + (k + 1)x + 1 = 0 \text{ has no real roots?}$$

Solution:

i) $kx^2 - (8k+4)x + 81 = 0$

Since the equation has real and equal roots, $\Delta = 0$.

$$\text{That is } b^2 - 4ac = 0 \text{ Here } a = k,$$

$$b = -(8k+4), c = 81$$

$$\text{That is, } [-(8k+4)]^2 - 4(k)(81) = 0$$

$$64k^2 + 64k + 16 - 324k = 0$$

$$64k^2 - 260k + 16 = 0$$

Dividing by 4 we get,

$$16k^2 - 65k + 1 = 0$$

$$(16k - 1)(k - 4) = 0$$

$$k = \frac{1}{16} \text{ or } k = 4.$$

ii) $(k + 9)x^2 + (k + 1)x + 1 = 0.$

Since the equation has real and equal roots,
 $\Delta < 0$

That is $b^2 - 4ac = 0.$

Here $a = k + 9, b = k + 1, c = 1$

That is, $(k + 1)^2 - 4(k + 9)(1) < 0$

$$k^2 + 2k + 1 - 4k - 36 < 0$$

$$k^2 - 2k - 35 < 0$$

$$(k + 5)(k - 7) < 0$$

Therefore, $-5 < k < 7.$ {If $\alpha < \beta$ and if $(x - \alpha)(x - \beta) < 0$ then, $\alpha < x < \beta$ }.

15. Determine the nature of the roots for the following quadratic equations

(i) $15x^2 + 11x + 2 = 0$

SEP-21

(ii) $x^2 - x - 1 = 0$

Solution:

(i) $15x^2 + 11x + 2 = 0$

$a = 15, b = 11, c = 2$

$\Delta = b^2 - 4ac$

$$= 11^2 - 4 \times 15 \times 2$$

$$= 121 - 120 = 1 = (+)ve$$

\therefore The roots are real and unequal.

(ii) $x^2 - x - 1 = 0$

$a = 1, b = -1, c = -1$

$\Delta = b^2 - 4ac$

$$= (-1)^2 - 4(1)(-1)$$

$$= 1 + 4 = 5$$

\therefore The roots are real and unequal.

16. A girl is twice as old as her sister. Five years hence, the product of their ages (in years) will be 375. Find their present ages.

Solution:

Let the present age of the girl and her sister be $2x, x.$

$$(x + 5)(2x + 5) = 375$$

$$\Rightarrow 2x^2 + 10x + 5x + 25 - 375 = 0$$

$$\Rightarrow 2x^2 + 15x - 350 = 0$$

$$\Rightarrow (x - 10)(2x + 35) = 0$$

$$x = 10, x = -\frac{35}{2} \text{ (x can't be Negative)}$$

\therefore The present ages are 20, 10 years old.

17. If $A = \begin{pmatrix} 2 & 5 \\ 4 & 3 \end{pmatrix}, B = \begin{pmatrix} 1 & -3 \\ 2 & 5 \end{pmatrix}$ find $AB,$

BA and verify $AB = BA?$

$$A = \begin{pmatrix} 2 & 5 \\ 4 & 3 \end{pmatrix}, B = \begin{pmatrix} 1 & -3 \\ 2 & 5 \end{pmatrix}$$

$$AB = \begin{pmatrix} 2 & 5 \\ 4 & 3 \end{pmatrix} \times \begin{pmatrix} 1 & -3 \\ 2 & 5 \end{pmatrix}$$

$$= \begin{pmatrix} 2+10 & -6+15 \\ 4+6 & -12+15 \end{pmatrix} = \begin{pmatrix} 12 & 9 \\ 10 & 3 \end{pmatrix} \quad \text{---(1)}$$

$$BA = \begin{pmatrix} 1 & -3 \\ 2 & 5 \end{pmatrix} \begin{pmatrix} 2 & 5 \\ 4 & 3 \end{pmatrix}$$

$$= \begin{pmatrix} 2-12 & 5-9 \\ 4+20 & 10+8 \end{pmatrix} = \begin{pmatrix} -8 & -4 \\ 24 & 18 \end{pmatrix} \quad \text{---(2)}$$

(1), (2) $\Rightarrow AB \neq BA$

We conclude, product matrix is not commutative.

18. Show that the matrices $A = \begin{pmatrix} 1 & 2 \\ 3 & 1 \end{pmatrix},$

$B = \begin{pmatrix} 1 & -2 \\ -3 & 1 \end{pmatrix}$ satisfy commutative

property $AB = BA$

Solution:

Given : $A = \begin{pmatrix} 1 & 2 \\ 3 & 1 \end{pmatrix}, B = \begin{pmatrix} 1 & -2 \\ -3 & 1 \end{pmatrix}$

$$AB = \begin{pmatrix} 1 & 2 \\ 3 & 1 \end{pmatrix} \times \begin{pmatrix} 1 & -2 \\ -3 & 1 \end{pmatrix}$$

$$= \begin{pmatrix} 1-6 & -2+2 \\ 3-3 & -6+1 \end{pmatrix} = \begin{pmatrix} -5 & 0 \\ 0 & -5 \end{pmatrix}$$

$$BA = \begin{pmatrix} 1 & -2 \\ -3 & 1 \end{pmatrix} \times \begin{pmatrix} 1 & 2 \\ 3 & 1 \end{pmatrix}$$

$$= \begin{pmatrix} 1-6 & -2+2 \\ -3+3 & -6+1 \end{pmatrix} = \begin{pmatrix} -5 & 0 \\ 0 & -5 \end{pmatrix}$$

(1), (2) $\Rightarrow AB = BA.$

Hence the commutative property Satisfied

19. Solve: $2x^2 - x - 1 = 0.$

Solution:

$$2x^2 - x - 1 = 0$$

Dividing 2 make co-efficient of x^2 as 1.

$$x^2 - \frac{x}{2} = \frac{1}{2}$$

$$x^2 - \frac{x}{2} + \left(\frac{1}{4}\right)^2 = \frac{1}{2} + \left(\frac{1}{4}\right)^2$$

$$\left(x - \frac{1}{4}\right)^2 = \frac{9}{16} = \left(\frac{3}{4}\right)^2$$

$$x = \frac{1}{4} + \frac{3}{4}$$

$$\Rightarrow x = 1 \text{ or } x = \frac{1}{4} - \frac{3}{4} = -\frac{1}{2}$$

20. If $A = \begin{pmatrix} \cos\theta & 0 \\ 0 & \cos\theta \end{pmatrix}$, $B = \begin{pmatrix} \sin\theta & 0 \\ 0 & \sin\theta \end{pmatrix}$

then show that $A^2 + B^2 = I$.

Solution:

$$A = \begin{pmatrix} \cos\theta & 0 \\ 0 & \cos\theta \end{pmatrix}, B = \begin{pmatrix} \sin\theta & 0 \\ 0 & \sin\theta \end{pmatrix}$$

Proof $A^2 + B^2 = I$

$$A^2 = A \cdot A$$

$$= \begin{pmatrix} \cos\theta & 0 \\ 0 & \cos\theta \end{pmatrix} \begin{pmatrix} \cos\theta & 0 \\ 0 & \cos\theta \end{pmatrix}$$

$$= \begin{pmatrix} \cos^2\theta + 0 & 0 + 0 \\ 0 + 0 & 0 + \cos^2\theta \end{pmatrix}$$

$$= \begin{pmatrix} \cos^2\theta & 0 \\ 0 & \cos^2\theta \end{pmatrix}$$

$$B^2 = B \cdot B$$

$$= \begin{pmatrix} \sin\theta & 0 \\ 0 & \sin\theta \end{pmatrix} \begin{pmatrix} \sin\theta & 0 \\ 0 & \sin\theta \end{pmatrix}$$

$$= \begin{pmatrix} \sin^2\theta + 0 & 0 + 0 \\ 0 + 0 & 0 + \sin^2\theta \end{pmatrix}$$

$$= \begin{pmatrix} \sin^2\theta & 0 \\ 0 & \sin^2\theta \end{pmatrix}$$

$$\therefore A^2 + B^2$$

$$= \begin{pmatrix} \cos^2\theta + \sin^2\theta & 0 \\ 0 & \cos^2\theta + \sin^2\theta \end{pmatrix}$$

$$= \begin{pmatrix} 1 & 0 \\ 0 & 1 \end{pmatrix} = I$$

$\therefore A^2 + B^2 = I$. Hence the proof.

21. If $A = \begin{pmatrix} \cos\theta & \sin\theta \\ -\sin\theta & \cos\theta \end{pmatrix}$ prove that $AA^T = I$.

Solution:

$$A = \begin{pmatrix} \cos\theta & \sin\theta \\ -\sin\theta & \cos\theta \end{pmatrix}$$

$$A^T = \begin{pmatrix} \cos\theta & -\sin\theta \\ \sin\theta & \cos\theta \end{pmatrix}$$

$$\begin{aligned} AA^T &= \begin{pmatrix} \cos\theta & \sin\theta \\ -\sin\theta & \cos\theta \end{pmatrix} \begin{pmatrix} \cos\theta & -\sin\theta \\ \sin\theta & \cos\theta \end{pmatrix} \\ &= \begin{pmatrix} \cos^2\theta + \sin^2\theta & 0 \\ \cos^2\theta & \sin^2\theta + \cos^2\theta \end{pmatrix} \\ &= \begin{pmatrix} 1 & 0 \\ 0 & 1 \end{pmatrix} = I \end{aligned}$$

22. Verify that $A^2 = I$ when $A = \begin{pmatrix} 5 & -4 \\ 6 & -5 \end{pmatrix}$

Solution:

$$\begin{aligned} A^2 &= A \times A = \begin{pmatrix} 5 & -4 \\ 6 & -5 \end{pmatrix} \begin{pmatrix} 5 & -4 \\ 6 & -5 \end{pmatrix} \\ &= \begin{pmatrix} 25 - 24 & -20 + 20 \\ 30 - 30 & -24 + 25 \end{pmatrix} \\ &= \begin{pmatrix} 1 & 0 \\ 0 & 1 \end{pmatrix} = I \end{aligned}$$

5 Marks**STAGE 2**

1. Solve the following system of linear equations in three variables

$$3x - 2y + z = 2, 2x + 3y - z = 5, x + y + z = 6.$$

Solution:

$$3x - 2y + z = 2 \quad \dots (1)$$

$$2x + 3y - z = 5 \quad \dots (2)$$

$$x + y + z = 6 \quad \dots (3)$$

Adding (1) and (2)

$$3x - 2y + z = 2$$

$$2x + 3y - z = 5(+)$$

$$5x + y = 7 \quad \dots (4)$$

Adding (2) and (3)

$$2x + 3y - z = 5$$

$$x + y + z = 6(+)$$

$$3x + 4y = 11 \quad \dots (5)$$

$$(4) \times 4 - (5)$$

$$20x + 4y = 28$$

$$3x + 4y = 11 (-)$$

$$17x = 17 \Rightarrow x = 1$$

Substituting $x = 1$ in (4), $5 + y = 7 \Rightarrow y = 2$

Substituting $x = 1, y = 2$ in (3), $1 + 2 + z = 6$

we get, $z = 3$

Therefore, $x = 1, y = 2, z = 3$

2. Solve: $x + 2y - z = 5$; $x - y + z = -2$;
 $-5x - 4y + z = -11$

Solution:

$$x + 2y - z = 5 \quad \dots (1)$$

$$x - y + z = -2 \quad \dots (2)$$

$$-5x - 4y + z = -11 \quad \dots (3)$$

Adding (1) and (2) we get

$$x + 2y - z = 5$$

$$x - y + z = -2(+)$$

$$2x + y = 3 \quad \dots (4)$$

Subtracting (2) and (3)

$$x - y + z = -2$$

$$-5x - 4y + z = -11 (-)$$

$$6x + 3y = 9$$

$$\text{Dividing by 3 } 2x + y = 3 \quad \dots (5)$$

Subtracting (4) and (5),

$$2x + y = 3$$

$$2x + y = 3$$

$$0 = 0$$

Here we arrive at an identity $0 = 0$.

Hence the system has an infinite number of solutions.

3. Solve: $3x + y - 3z = 1$; $-2x - y + 2z = 1$;
 $-x - y + z = 2$.

Solution:

$$3x + y - 3z = 1 \quad \dots (1)$$

$$-2x - y + 2z = 1 \quad \dots (2)$$

$$-x - y + z = 2 \quad \dots (3)$$

Adding (1) and (2),

$$3x + y - 3z = 1$$

$$-2x - y + 2z = 1(+)$$

$$x - z = 2 \quad \dots (4)$$

Adding (1) and (3),

$$3x + y - 3z = 1$$

$$-x - y + z = 2(+)$$

$$2x - 2z = 3 \dots (5)$$

$$(5) \times 1 \Rightarrow 2x - 2z = 3$$

$$(4) \times 2 \Rightarrow 2x - 2z = 4 (-)$$

$$0 = -1$$

Here we arrive at a contradiction as $0 \neq -1$.

This means that the system is inconsistent and has no solution.

4. Solve $\frac{x}{2} - 1 = \frac{y}{6} + 1 = \frac{z}{7} + 2; \frac{y}{3} + \frac{z}{2} = 13$

Solution:

$$\frac{x}{2} - 1 = \frac{y}{6} + 1$$

$$\frac{x}{2} - \frac{y}{6} = 1 + 1$$

$$\Rightarrow \frac{6x - 2y}{12} = 2$$

$$\Rightarrow \frac{2(3x - y)}{12} = 2$$

$$\Rightarrow \frac{3x - y}{6} = 2$$

$$\Rightarrow 3x - y = 12 \dots (1)$$

Considering

$$\frac{x}{2} - 1 = \frac{z}{7} + 2$$

$$\frac{x}{2} - \frac{z}{7} = 1 + 2$$

$$\Rightarrow \frac{7x - 2z}{14} = 3$$

$$\Rightarrow 7x - 2z = 42 \dots (2)$$

$$\frac{y}{3} + \frac{z}{2} = 13$$

$$\Rightarrow \frac{2y + 3z}{6} = 13$$

$$\Rightarrow 2y + 3z = 78 \dots (3)$$

Eliminating z from (2) and (3)

$$(2) \times 3 \Rightarrow 21x - 6z = 126$$

$$(3) \times 2 \Rightarrow 4y + 6z = 156 (+)$$

$$\hline 21x + 4y = 282$$

$$(1) \times 4 \Rightarrow 12x - 4y = 48 (+)$$

$$\hline 33x = 330 \Rightarrow x = 10$$

Substituting $x = 10$ in (1), $30 - y = 12$ we get,

$$y = 18$$

Substituting $x = 10$ in (2), $70 - 2z = 42$ then

$$z = 14$$

$$\Rightarrow x = 10, y = 18, z = 14.$$

5. Solve : $\frac{1}{2x} + \frac{1}{4y} - \frac{1}{3z} = \frac{1}{4}; \frac{1}{x} = \frac{1}{3y};$

$$\frac{1}{x} - \frac{1}{5y} + \frac{4}{z} = 2 \frac{2}{15}$$

Solution:

Let $\frac{1}{x} = p, \frac{1}{y} = q, \frac{1}{z} = r$

The given equations are written as

$$\frac{p}{2} + \frac{q}{4} - \frac{r}{3} = \frac{1}{4}$$

$$\frac{6p + 3q - 4r}{12} = \frac{1}{4}$$

$$6p + 3q - 4r = 3 \dots (1)$$

$$p = \frac{q}{3}$$

$$3p = q \dots (2)$$

$$p - \frac{q}{5} + 4r = 2 \frac{2}{15} = \frac{32}{15}$$

$$15p - 3q + 60r = 32 \dots (3)$$

Substituting (2) in (1) we get

$$6p + 3(3p) - 4r = 3$$

$$6p + 9p - 4r = 3$$

$$15p - 4r = 3 \dots (4)$$

Substituting (2) in (3) we get

$$15p - 3(3p) + 60r = 32$$

$$15p - 9p + 60r = 32$$

$$6p + 60r = 32 (\div 3)$$

$$3p + 30r = 16 \dots (5)$$

Solve (4) and (5)

$$15p - 4r = 3$$

$$(5) \times 5 \Rightarrow 15p + 150r = 80 (-)$$

$$\hline -154r = -77$$

we get, $r = \frac{1}{2}$

Substituting $r = \frac{1}{2}$ in (4) we get,

$$15p - 2 = 3 \Rightarrow p = \frac{1}{3}$$

From (2), $q = 3p$, we get $q = 1$

Therefore, $x = \frac{1}{p} = 3, y = \frac{1}{q} = 1, z = \frac{1}{r} = 2.$

i.e., $x = 3, y = 1, z = 2.$

6. The sum of thrice the first number, second number and twice the third number is 5. If thrice the second number is subtracted from the sum of first number and thrice the third we get 2. If the third number is subtracted from the sum of twice the first, thrice the second, we get 1. Find the numbers.

Solution:

Let the three numbers be $x, y, z.$

From the given data we get the following equations

$$3x + y + 2z = 5 \dots (1)$$

$$x - 3y + 3z = 2 \dots (2)$$

$$2x + 3y - z = 1 \dots (3)$$

$$(1) \times 1 \Rightarrow 3x + y + 2z = 5$$

$$(2) \times 3 \Rightarrow 3x - 9y + 9z = 6 (-)$$

$$\hline 10y - 7z = -1 \dots (4)$$

$$(1) \times 2 \Rightarrow 6x + 2y + 4z = 10$$

$$(3) \times 3 \Rightarrow 6x + 9y - 3z = 3 (-)$$

$$\hline -7y + 7z = 7 \dots (5)$$

Adding (4) and (5)

$$10y - 7z = -1$$

$$\hline -7y + 7z = 7$$

$$\hline 3y = 6 \Rightarrow y = 2$$

Substituting $y = 2$ in (5),

$$-14 + 7z = 7$$

$$\Rightarrow 7z = 7 + 14 = 21$$

$$z = 3$$

Substituting $y = 2$ and $z = 3$ in (1),

$$3x + 2 + 6 = 5$$

$$\Rightarrow 3x + 8 = 5$$

$$\Rightarrow 3x = -3$$

$$x = -1$$

Therefore, $x = -1, y = 2, z = 3$.

7. Solve the following system of linear equations in three variables

SEP-21

$$x + y + z = 5; 2x - y + z = 9; x - 2y + 3z = 16$$

Solution:

$$x + y + z = 5 \quad \dots (1)$$

$$2x - y + z = 9 \quad \dots (2)$$

$$x - 2y + 3z = 16 \quad \dots (3)$$

$$(1) - (3) \Rightarrow 3y - 2z = -11 \quad \dots (4)$$

$$(2) \Rightarrow 2x - y + z = 9$$

$$(1) \times 2 \Rightarrow 2x + 2y + 2z = 10 \quad (-)$$

$$-3y - z = -1 \quad \dots (5)$$

$$(4) + (5)$$

$$3y - 2z = -11$$

$$-3y - z = -1(+)$$

$$-3z = -12$$

$$z = 4$$

Substitute $z = 4$ in (5)

$$-3y - 4 = -1$$

$$\Rightarrow -3y = 3$$

$$\Rightarrow y = -1$$

Substitute $y = -1, z = 4$ in (1)

$$\Rightarrow x - 1 + 4 = 5$$

$$\Rightarrow x + 3 = 5$$

$$\Rightarrow x = 2$$

Therefore, $x = 2, y = -1, z = 4$

8. Discuss the nature of solutions of the following system of equation

$$x + 2y - z = 6; -3x - 2y + 5z = -12;$$

$$x - 2z = 3$$

Solution:

$$x + 2y - z = 6 \quad \dots (1)$$

$$-3x - 2y + 5z = -12 \quad \dots (2)$$

$$x - 2z = 3 \quad \dots (3)$$

$$(1) + (2) \Rightarrow -2x + 4z = -6 \quad \dots (4)$$

$$(4) + (3) \times 2 \Rightarrow 2x - 4z = 6$$

$$0 = 0$$

Here we arrive at an identity $0 = 0$.

Hence the system has an infinite number of solution.

9. Vani, her father and her grand father have an average age of 53. One-half of her grand father's age plus one-third of her father's age plus one fourth of Vani's age is 65. Four years ago if Vani's grandfather was four times as old as Vani then how old are they all now?

Solution:

Let the present age of Vani, her father, grand father be x, y, z respectively.

By data given,

$$\frac{x + y + z}{3} = 53$$

$$\Rightarrow x + y + z = 159 \quad \dots (1)$$

$$\frac{1}{2}z + \frac{1}{3}y + \frac{1}{4}x = 65$$

$$\frac{6z + 4y + 3x}{12} = 65$$

$$3x + 4y + 6z = 780 \quad \dots (2)$$

$$(z - 4) = 4(x - 4)$$

$$\Rightarrow 4x - z = 12 \quad \dots (3)$$

From (1) & (2)

$$(1) \times 4 \Rightarrow 4x + 4y + 4z = 636$$

$$(2) \Rightarrow 3x + 4y + 6z = 780$$

$$(subtracting) \quad x - 2z = -144 \quad \dots (4)$$

From (3) & (4)

$$(3) \times 2 \Rightarrow 8x - 2z = 24$$

$$(4) \Rightarrow x - 2z = -144$$

$$(subtracting) \quad 7x = 168 \quad \dots (5)$$

$$x = \frac{168}{7} = 24$$

Substitute $x = 24$ in (3)

$$4(24) - z = 12$$

$$96 - z = 12$$

$$z = 84$$

$$(1) \Rightarrow 24 + y + 84 = 159$$

$$\Rightarrow y = 51$$

∴ Vani's Present Age = 24 years
 Father's Present Age = 51 years
 Grand father's Age = 84 years

10. Discuss the nature of solutions of the following system of equation

(ii) $2y + z = 3(-x + 1)$; $-x + 3y - z = -4$;

$$3x + 2y + z = -\frac{1}{2}$$

Solution:

$$\begin{aligned} 2y + z &= 3(-x + 1) \\ \Rightarrow 2y + z &= -3x + 3 \\ \Rightarrow 3x + 2y + z &= -3 \dots\dots(1) \\ -x + 3y - z &= -4 \dots\dots(2) \\ 3x + 2y + z &= -\frac{1}{2} \\ \Rightarrow 6x + 4y + 2z &= -1 \dots\dots(3) \\ (1) + (2) \Rightarrow 3x + 2y + z &= -3 \\ -x + 3y - z &= -4 \\ \hline 2x + 5y &= -7 \dots\dots(4) \end{aligned}$$

From (1) & (3)

$$(1) \times 2 \Rightarrow 6x + 4y + 2z = -6$$

$$(3) \times 1 \Rightarrow 6x + 4y + 2z = -1 \quad (-)$$

$$0 \neq -5$$

Here, we arrive at a contradiction as $0 \neq -5$. This means that the system is inconsistent and has no solution.

11. Find the GCD of the polynomials

$x^3 + x^2 - x + 2$ and $2x^3 - 5x^2 + 5x - 3$.

Solution:

Let $f(x) = 2x^3 - 5x^2 + 5x - 3$ and

$g(x) = x^3 + x^2 - x + 2$

$$\begin{array}{r} x^3 + x^2 - x + 2 \quad 2 \\ \hline 2x^3 - 5x^2 + 5x - 3 \\ \hline 2x^3 + 2x^2 - 2x + 4 \quad (-) \\ \hline -7x^2 + 7x - 7 \\ \hline = -7(x^2 - x + 1) \end{array}$$

$$-7(x^2 - x + 1) \neq 0,$$

note that -7 is not a divisor of $g(x)$.

Now dividing $g(x) = x^3 + x^2 - x + 2$ by the new remainder $x^2 - x + 1$ (leaving the constant factor), we get

$$\begin{array}{r} x+2 \\ \hline x^2 - x + 1 \quad \overline{) \quad x^3 + x^2 - x + 2} \\ \hline x^3 - x^2 + x \quad (-) \\ \hline 2x^2 - 2x + 2 \\ \hline 2x^2 - 2x + 2 \\ \hline 0 \end{array}$$

Here we get zero remainder.

Therefore, GCD $(2x^3 - 5x^2 + 5x - 3, x^3 + x^2 - x + 2) = x^2 - x + 1$

12. Find the GCD of $6x^3 - 30x^2 + 60x - 48$ and $3x^3 - 12x^2 + 21x - 18$.

Solution:

$$\begin{aligned} f(x) &= 6x^3 - 30x^2 + 60x - 48 \\ &= 6(x^3 - 5x^2 + 10x - 8) \end{aligned}$$

$$\begin{aligned} \text{and } g(x) &= 3x^3 - 12x^2 + 21x - 18 \\ &= 3(x^3 - 4x^2 + 7x - 6) \end{aligned}$$

Now, we shall find the GCD of

$$x^3 - 5x^2 + 10x - 8 \text{ and } x^3 - 4x^2 + 7x - 6$$

$$\begin{array}{r} 1 \\ \hline x^3 - 5x^2 + 10x - 8 \quad \overline{) \quad x^3 - 4x^2 + 7x - 6} \\ \hline -8x^3 + 5x^2 + 10x - 8 \quad (-) \\ \hline x^2 - 3x + 2 \end{array}$$

$$\begin{array}{r} x-2 \\ \hline x^2 - 3x + 2 \quad \overline{) \quad x^3 - 5x^2 + 10x - 8} \\ \hline x^3 - 3x^2 + 2x \\ \hline -2x^2 + 8x - 8 \\ \hline -2x^2 + 6x - 4 \quad (-) \\ \hline 2x - 4 \\ \hline = 2(x - 2) \end{array}$$

$$\begin{array}{r} x-1 \\ \hline x-2 \quad \overline{) \quad x^2 - 3x + 2} \\ \hline x^2 - 2x \quad (-) \\ \hline -x + 2 \\ \hline -x + 2 \quad (-) \\ \hline 0 \end{array}$$

Here, we get zero as remainder, GCD of leading coefficients 3 and 6 is 3.

Thus, GCD $[(6x^3 - 30x^2 + 60x - 48, 3x^3 - 12x^2 + 21x - 18)] = 3(x - 2)$

13. Find the GCD of the given polynomials

(i) $x^4 + 3x^3 - x - 3, x^3 + x^2 - 5x + 3$ **SEP-20**

(ii) $x^4 - 1, x^3 - 11x^2 + x - 11$

(iii) $3x^4 + 6x^3 - 12x^2 - 24x, 4x^4 + 14x^3 + 8x^2 - 8x$

(iv) $3x^3 + 3x^2 + 3x + 3, 6x^3 + 12x^2 + 6x + 12$

Solution:

i. $f(x) = x^4 + 3x^3 + x - 3$ and

$g(x) = x^3 + x^2 - 5x + 3$

$$\begin{array}{r}
 x^3 + x^2 - 5x \\
 + 3 \quad \begin{array}{l} x+2 \\ \hline x^4 + 3x^3 + 0 - x - 3 \\ x^4 + x^3 - 5x^2 + 3x \\ \hline 2x^3 + 5x^2 - 4x - 3 \\ 2x^3 + 2x^2 - 10x + 6 \quad (-) \\ \hline 3x^2 + 6x - 9 \\ = 3(x^2 + 2x - 3) \end{array}
 \end{array}$$

$$\begin{array}{r}
 x^2 + 2x - 3 \\
 \begin{array}{l} x-1 \\ \hline x^3 + x^2 - 5x + 3 \\ x^3 + 2x^2 - 3x \quad (-) \\ \hline -x^2 - 2x + 3 \\ -x^2 - 2x + 3 \quad (-) \\ \hline 0 \end{array}
 \end{array}$$

$\therefore \text{GCD of } (f(x), g(x)) = x^2 + 2x - 3$

ii. $f(x) = x^4 - 1$ and $g(x) = x^3 - 11x^2 + x - 11$

$$\begin{array}{r}
 x^3 - 11x^2 + x - 11 \\
 \begin{array}{l} x+11 \\ \hline x^4 + 0x^3 + 0x^2 - 0x - 1 \\ x^4 - 11x^3 + x^2 - 11x \quad (-) \\ \hline 11x^3 - x^2 + 11x - 1 \\ 11x^3 - 121x^2 + 11x - 121 \quad (-) \\ \hline 120x^2 + 120 \\ = 120(x^2 + 1) \end{array}
 \end{array}$$

$$\begin{array}{r}
 x^2 - 0x + 1 \\
 \begin{array}{l} x-11 \\ \hline x^3 - 11x^2 + x - 11 \\ x^3 + 0x^2 + x \quad (-) \\ \hline -11x^2 + 0x - 11 \\ -11x^2 + 0x - 11 \quad (-) \\ \hline 0 \end{array}
 \end{array}$$

$\therefore \text{GCD of } (f(x), g(x)) = x^2 + 1$

iii. $f(x) = 3x^4 + 6x^3 - 12x^2 - 24x$

$= 3x(x^3 + 2x^2 - 4x - 8)$

$g(x) = 4x^4 + 14x^3 + 8x^2 - 8x$

$= 2x(2x^3 + 7x^2 + 4x - 4)$

G.C.D of $(3x, 2x)$ is x

$$\begin{array}{r}
 x^3 + 2x^2 - 4x \\
 - 8 \quad \begin{array}{l} 2x+3 \\ \hline 2x^3 + 7x^2 + 4x - 4 \\ 2x^3 + 4x^2 - 8x - 16 \quad (-) \\ \hline 3x^2 + 12x + 12 \\ = 3(x^2 + 4x + 4) \end{array} \\
 \hline x-2
 \end{array}$$

$$\begin{array}{r}
 x^2 + 4x + 4 \\
 \begin{array}{l} x^3 + 2x^2 - 4x - 8 \\ x^3 + 4x^2 + 4x \quad (-) \\ \hline -2x^2 - 8x - 8 \\ -2x^2 - 8x - 8 \quad (-) \\ \hline 0 \end{array}
 \end{array}$$

$\therefore \text{GCD of } (f(x), g(x)) = x(x^2 + 4x + 4)$

iv. $f(x) = 3x^3 + 3x^2 + 3x + 3$

$= 3(x^3 + x^2 + x + 1)$

$g(x) = 6x^3 + 12x^2 + 6x + 12$

$= 6(x^3 + 2x^2 + x + 2)$

GCD of $(3, 6) = 3$

$$\begin{array}{r}
 x^3 + x^2 + x + 1 \\
 \begin{array}{l} 1 \\ \hline x^3 + 2x^2 + x + 2 \\ x^3 + x^2 + x + 1 \quad (-) \\ \hline x^2 + 0x + 1 \end{array}
 \end{array}$$

$$\begin{array}{r}
 x^2 + 0x + 1 \\
 \begin{array}{l} x+1 \\ \hline x^3 + x^2 + x + 1 \\ x^3 + 0x^2 + x \quad (-) \\ \hline x^2 + 0x + 1 \\ x^2 + 0x + 1 \\ \hline 0 \end{array}
 \end{array}$$

$\therefore \text{GCD of } (f(x), g(x)) = 3(x^2 + 1)$

14. Find the GCD of each pair of the following polynomials

(i) $12(x^4 - x^3)$, $8(x^4 - 3x^3 + 2x^2)$ whose LCM is $24x^3(x-1)(x-2)$

(ii) $(x^3 + y^3)$, $(x^4 + x^2y^2 + y^4)$ whose LCM is $(x^3 + y^3)(x^2 + xy + y^2)$

Solution:

i) $f(x) = 12(x^4 - x^3) = 2^2 \times 3 \times (x^3) \times (x-1)$

$g(x) = 8(x^4 - 3x^3 + 2x^2) = 2^3 \times (x^2) \times$

$(x^2 - 3x + 2)$

$= 2^3 \times (x^2) \times (x-2)(x-1)$

LCM = $24x^3(x-1)(x-2)$

LCM = $\frac{f(x) \times g(x)}{\text{GCD}}$

GCD = $\frac{f(x) \times g(x)}{\text{LCM}}$

$= \frac{2^2 \times 3 \times (x^2) \times (x-1) \times 2^3 \times (x^2) \times (x-2)(x-1)}{24x^3(x-1)(x-2)}$

$= 2^2 \times (x^2) \times (x-1)$

GCD = $4x^2(x-1)$

ii) $f(x) = x^3 + y^3 = (x + y)(x^2 - xy + y^2)$
 $g(x) = x^4 + x^2y^2 + y^4$
 $= (x^2 - xy + y^2)(x^2 + xy + y^2)$
 $\text{LCM} = (x^3 + y^3)(x^2 + xy + y^2)$
 $= (x + y)(x^2 - xy + y^2)(x^2 + xy + y^2)$
 $\text{GCD} = \frac{f(x) \times g(x)}{\text{LCM}}$
 $= \frac{(x + y)(x^2 - xy + y^2)(x^2 - xy + y^2)(x^2 + xy + y^2)}{(x + y)(x^2 - xy + y^2)(x^2 + xy + y^2)}$
 $\therefore \text{GCD} = x^2 - xy + y^2$

15. Simplify: $\frac{b^2 + 3b - 28}{b^2 + 4b + 4} \div \frac{b^2 - 49}{b^2 - 5b - 14}$

Solution:

$$\frac{b^2 + 3b - 28}{b^2 + 4b + 4} \div \frac{b^2 - 49}{b^2 - 5b - 14}$$

$$= \frac{(b-4)(b+7)}{(b+2)(b+2)} \times \frac{(b-7)(b+2)}{(b+7)(b-7)}$$

$$= \frac{b-4}{b+2}$$

16. If $x = \frac{a^2 + 3a - 4}{3a^2 - 3}$ and $y = \frac{a^2 + 2a - 8}{2a^2 - 2a - 4}$
 find the value of x^2y^2 .

Solution:

$$x = \frac{a^2 + 3a - 4}{3a^2 - 3} = \frac{(a+4)(a-1)}{3(a+1)(a-1)} = \frac{(a+4)}{3(a+1)}$$

$$x^2 = \frac{(a+4)^2}{9(a+1)^2}$$

$$y = \frac{a^2 + 2a - 8}{2a^2 - 2a - 4} = \frac{(a+4)(a-2)}{2(a+1)(a-2)} = \frac{(a+4)}{2(a+1)}$$

$$y^2 = \frac{(a+4)^2}{4(a+1)^2} \Rightarrow y^{-2} = \frac{4(a+1)^2}{(a+4)^2}$$

$$x^2y^{-2} = \frac{(a+4)^2}{9(a+1)^2} \cdot \frac{4(a+1)^2}{(a+4)^2} = \frac{4}{9}$$

17. If $A = \frac{2x+1}{2x-1}$, $B = \frac{2x-1}{2x+1}$
 find $\frac{1}{A-B} - \frac{2B}{A^2-B^2}$

Solution:

$$\frac{1}{A-B} - \frac{2B}{A^2-B^2}$$

$$= \frac{1}{A-B} - \frac{2B}{(A+B)(A-B)}$$

$$= \frac{A+B-2B}{(A+B)(A-B)} = \frac{(A-B)}{(A+B)(A-B)}$$

$$= \frac{1}{A+B} = \frac{1}{\frac{2x+1}{2x-1} + \frac{2x-1}{2x+1}}$$

$$= \frac{1}{\frac{(2x+1)^2 + (2x-1)^2}{(2x+1)(2x-1)}}$$

$$= \frac{(2x+1)(2x-1)}{(2x+1)^2 + (2x-1)^2}$$

$$= \frac{[2x]^2 - 1^2}{4x^2 + 1 + 4x + 4x^2 + 1 - 4x}$$

$$= \frac{4x^2 - 1}{8x^2 + 2} = \frac{4x^2 - 1}{2(4x^2 + 1)}$$

18. If $A = \frac{x}{x+1}$, $B = \frac{1}{x+1}$

prove that $\frac{(A+B)^2 + (A-B)^2}{A \div B} = \frac{2(x^2+1)}{x(x+1)^2}$

Solution:

Given $A = \frac{x}{x+1}$, $B = \frac{1}{x+1}$

$$\frac{(A+B)^2 + (A-B)^2}{A \div B} = \frac{2(A^2+B^2)}{A \div B}$$

$$A^2+B^2 = \frac{x^2}{(x+1)^2} + \frac{1}{(x+1)^2} = \frac{x^2+1}{(x+1)^2}$$

$$A \div B = \frac{x}{x+1} \times \frac{x+1}{1} = x$$

$$\frac{2(A^2+B^2)}{A \div B} = (2) \left(\frac{x^2+1}{(x+1)^2} \right) \left(\frac{1}{x} \right)$$

$$= \frac{2(x^2+1)}{x(x+1)^2}$$

19. Pari needs 4 hours to complete a work. His friend Yuvan needs 6 hours to complete the same work. How long will it take to complete if they work together?

Solution:

From the given,

Pari Work done by in 1 hour = $\frac{1}{4}$

Yuvan Work done by in 1 hour = $\frac{1}{6}$

Pari and Yuvan Work done by in 1⁶ hour

$$= \frac{1}{4} + \frac{1}{6} = \frac{10}{24}$$

They work together, take time to complete

the work = $\frac{24}{10}$ hours

$$= 2 \text{ hours } 24 \text{ minutes}$$

20. Iniya bought 50 kg of fruits consisting of apples and bananas. She paid twice as much per kg for the apple as she did for the banana. If Iniya bought ₹1800 worth of apples and ₹600 worth bananas, then how many kgs of each fruit did she buy?

Solution:

Let x be the number of kgs of apples;

y be the number of kgs of bananas

Let 1kg of banana = ₹ z

∴ 1kg of Apple = ₹ $2z$

Given $x+y = 50$ — (1)

$x \times (2z) = 1800$

$$\Rightarrow x = \frac{1800}{2z} = \frac{900}{z}$$

$$y \times z = 600; \Rightarrow y = \frac{600}{z}$$

Substitute x and y in eqn (1)

$$x+y = 50$$

$$\Rightarrow \frac{900}{z} + \frac{600}{z} = 50$$

$$\Rightarrow \frac{1500}{z} = 50$$

$$\Rightarrow 1500 = 50z$$

$$z = \frac{1500}{50} = 30$$

$$\Rightarrow \therefore z = 30$$

$$\therefore x = \frac{900}{30} = 30 \quad y = \frac{600}{30} = 20$$

$$\Rightarrow x = 30 \text{ and } y = 20$$

Hence Iniya bought 30 kgs of apples and 20 kg of bananas

21. Simplify:

$$\frac{1}{x^2 - 5x + 6} + \frac{1}{x^2 - 3x + 2} - \frac{1}{x^2 - 8x + 15}$$

Solution:

$$\frac{1}{x^2 - 5x + 6} + \frac{1}{x^2 - 3x + 2} - \frac{1}{x^2 - 8x + 15}$$

$$= \frac{1}{(x-2)(x-3)} + \frac{1}{(x-2)(x-1)} - \frac{1}{(x-5)(x-3)}$$

$$= \frac{(x-1)(x-5) + (x-3)(x-5) - (x-1)(x-2)}{(x-1)(x-2)(x-3)(x-5)}$$

$$= \frac{(x^2 - 6x + 5) + (x^2 - 8x + 15) - (x^2 - 3x + 2)}{(x-1)(x-2)(x-3)(x-5)}$$

$$= \frac{x^2 - 11x + 18}{(x-1)(x-2)(x-3)(x-5)}$$

$$= \frac{(x-9)(x-2)}{(x-1)(x-2)(x-3)(x-5)}$$

$$= \frac{x-9}{(x-1)(x-3)(x-5)}$$

22. Find the square root of the following expressions

(i) $16x^2 + 9y^2 - 24xy + 24x - 18y + 9$

(ii) $(6x^2 + x - 1)(3x^2 + 2x - 1)(2x^2 + 3x + 1)$

(iii) $\left[\sqrt{15}x^2 + (\sqrt{3} + \sqrt{10})x + \sqrt{2} \right] \left[5 \quad 2 \quad 5 \quad 1 \quad 2 \right]$

$$\left[\sqrt{5}x^2 + (2\sqrt{5} + 1)x + 2 \right]$$

$$\left[\sqrt{3}x^2 + (\sqrt{2} + 2\sqrt{3})x + 2\sqrt{2} \right]$$

Solution:

i) $16x^2 + 9y^2 - 24xy + 24x - 18y + 9$

$$= \sqrt{(4x)^2 + (-3y)^2 + 3^2 + 2(4x)(-3y) + 2(-3y)(3) + 2(4x)(3)}$$

$$\therefore \sqrt{(4x - 3y + 3)^2} = |4x - 3y + 3|$$

ii) $\sqrt{(6x^2 + x - 1)(3x^2 + 2x - 1)(2x^2 + 3x + 1)}$

$$= \sqrt{(3x-1)(2x+1)(3x-1)(x+1)(2x+1)(x+1)}$$

$$= |(3x-1)(2x+1)(x+1)|$$

iii) First let us factorize the polynomials

$$\sqrt{15}x^2 + (\sqrt{3} + \sqrt{10})x + \sqrt{2} =$$

$$\sqrt{15}x^2 + \sqrt{3}x + \sqrt{10}x + \sqrt{2}$$

$$= \sqrt{3}x(\sqrt{5}x+1) + \sqrt{2}(\sqrt{5}x+1)$$

$$= (\sqrt{5}x+1) \times (\sqrt{3}x + \sqrt{2})$$

$$\sqrt{5}x^2 + (2\sqrt{5} + 1)x + 2 = \sqrt{5}x^2 + 2\sqrt{5}x + x + 2$$

$$= \sqrt{5}x(x+2) + 1(x+2) = (\sqrt{5}x+1)(x+2)$$

$$\sqrt{3}x^2 + (\sqrt{2} + 2\sqrt{3})x + 2\sqrt{2} =$$

$$\sqrt{3}x^2 + \sqrt{2}x + 2\sqrt{3}x + 2\sqrt{2}$$

$$= x(\sqrt{3}x + \sqrt{2}) + 2(\sqrt{3}x + \sqrt{2})$$

$$= (x+2)(\sqrt{3}x + \sqrt{2})$$

Therefore,

$$\sqrt{\left[\sqrt{15}x^2 + (\sqrt{3} + \sqrt{10})x + \sqrt{2} \right] \left[\sqrt{5}x^2 + (2\sqrt{5} + 1)x + 2 \right] \left[\sqrt{3}x^2 + (\sqrt{2} + 2\sqrt{3})x + 2\sqrt{2} \right]} \quad 3$$

$$\sqrt{\left[\sqrt{3}x^2 + (\sqrt{2} + 2\sqrt{3})x + 2\sqrt{2} \right]}$$

$$= \sqrt{(\sqrt{5}x+1)(\sqrt{3}x+\sqrt{2})(\sqrt{5}x+1)(x+2)(\sqrt{3}x+\sqrt{2})(x+2)}$$

$$= \left| (\sqrt{5}x+1)(\sqrt{3}x+\sqrt{2})(x+2) \right|$$

23. Solve $x^2 + 2x - 2 = 0$ by formula method**Solution:**

Compare $x^2 + 2x - 2 = 0$ with the standard form $ax^2 + bx + c = 0$

$$a = 1, b = 2, c = -2$$

Substituting the values of a, b and c in the formula we get,

$$x = \frac{-b \pm \sqrt{b^2 - 4ac}}{2a}$$

$$x = \frac{-2 \pm \sqrt{(2)^2 - 4(1)(-2)}}{2(1)} = \frac{-2 \pm \sqrt{4+8}}{2}$$

$$= \frac{-2 \pm \sqrt{12}}{2} = \frac{-2 \pm 2\sqrt{3}}{2} = -1 \pm \sqrt{3}$$

Therefore, $x = -1 + \sqrt{3}, x = -1 - \sqrt{3}$

24. Solve $2x^2 - 3x - 3 = 0$ by formula method.**Solution:**

Compare $2x^2 - 3x - 3 = 0$ with the standard form $ax^2 + bx + c = 0$

$$a = 2, b = -3, c = -3$$

substituting the values of a, b and c in the formula we get,

$$x = \frac{-b \pm \sqrt{b^2 - 4ac}}{2a}$$

$$x = \frac{-(-3) \pm \sqrt{(-3)^2 - 4(2)(-3)}}{2(2)} = \frac{3 \pm \sqrt{9+24}}{4}$$

$$= \frac{3 \pm \sqrt{33}}{4}$$

Therefore, $x = \frac{3 + \sqrt{33}}{4}, x = \frac{3 - \sqrt{33}}{4}$

25. Solve $3p^2 + 2\sqrt{5}p - 5 = 0$ by formula method.**Solution:**

Compare $3p^2 + 2\sqrt{5}p - 5 = 0$ with the standard form $ax^2 + bx + c = 0$

$$a = 3, b = 2\sqrt{5}, c = -5$$

substituting the values of a, b and c in the formula we get,

$$x = \frac{-b \pm \sqrt{b^2 - 4ac}}{2a}$$

$$x = \frac{-2\sqrt{5} \pm \sqrt{(2\sqrt{5})^2 - 4(3)(-5)}}{2(3)}$$

$$= \frac{-2\sqrt{5} \pm \sqrt{20+60}}{6} = \frac{-2\sqrt{5} \pm \sqrt{80}}{6}$$

$$= \frac{-2\sqrt{5} \pm 4\sqrt{5}}{6} = \frac{-\sqrt{5} \pm 2\sqrt{5}}{3}$$

$$\text{Therefore, } x = \frac{\sqrt{5}}{3}, x = -\sqrt{5}$$

26. Solve $pqx^2 - (p+q)^2x + (p+q)^2 = 0$ [May 22]**Solution:**

Compare the coefficients of $pqx^2 - (p+q)^2x + (p+q)^2 = 0$ with the standard form $ax^2 + bx + c = 0$

$$a = pq, b = -(p+q)^2, c = (p+q)^2$$

substituting the values of a, b and c in the formula we get,

$$x = \frac{-b \pm \sqrt{b^2 - 4ac}}{2a}$$

$$= \frac{-(-(p+q)^2) \pm \sqrt{(-(p+q)^2)^2 - 4pq(p+q)^2}}{2pq}$$

$$= \frac{(p+q)^2 \pm \sqrt{(p+q)^4 - 4pq(p+q)^2}}{2pq}$$

$$= \frac{(p+q)^2 \pm \sqrt{(p+q)^2[(p+q)^2 - 4pq]}}{2pq}$$

$$= \frac{(p+q)^2 \pm \sqrt{(p+q)^2[p^2 + q^2 + 2pq - 4pq]}}{2pq}$$

$$= \frac{(p+q)^2 \pm \sqrt{(p+q)^2(p-q)^2}}{2pq}$$

$$= \frac{(p+q)^2 \pm (p+q)(p-q)}{2pq}$$

$$= \frac{(p+q)[(p+q) \pm (p-q)]}{2pq}$$

$$= \frac{(p+q)[p+q+p-q]}{2pq}, \frac{(p+q)[p+q-p+q]}{2pq}$$

$$= \frac{(p+q)[2p]}{2pq}, \frac{(p+q)[2q]}{2pq}$$

$$x = \frac{p+q}{q}, \frac{p+q}{p}$$

27. The product of Kumaran's age (in years) two years ago and his age four years from now is one more than twice his present age. What is his present age?**Solution:**

Let the present age of Kumaran be x years.

Two years ago, his age is $(x - 2)$ years.

Four years from now, his age = $(x + 4)$ years

Given

$$(x-2)(x+4) = 1 + 2x$$

$$x^2 + 2x - 8 = 1 + 2x$$

$$x^2 - 9 = 0$$

gives $(x-3)(x+3) = 0$

Then, $x = \pm 3$ (Rejecting -3 as age cannot be negative).

Kumaran's present age is 3 years.

- 28. A passenger train takes 1 hr more than an express train to travel a distance of 240 km from Chennai to Virudhachalam. The speed of passenger train is less than that of an express train by 20 km per hour. Find the average speed of both the trains.**

Solution:

Let the average speed of passenger train be x km/hr.

Then the average speed of express train will be $(x + 20)$ km/hr.

Time taken by the passenger train to cover distance of 240 km = $\frac{240}{x}$ hr

Time taken by the express train to cover distance of 240 km = $\frac{240}{x+20}$ hr

Given, $\frac{240}{x} = \frac{240}{x+20} + 1$

$$\frac{240}{x} - \frac{240}{x+20} = 1$$

$$240 \left[\frac{1}{x} - \frac{1}{x+20} \right] = 1$$

$$\Rightarrow 240 \left[\frac{x+20-x}{x(x+20)} \right] = 1$$

$$\Rightarrow 4800 = (x^2+20x)$$

$$x^2 + 20x - 4800 = 0$$

$$\Rightarrow (x+80)(x-60) = 0$$

$$\Rightarrow x = -80 \text{ or } 60$$

Therefore $x = 60$ (Rejecting -80 as speed cannot be negative)

Average speed of the passenger train is 60 km/hr.

Average speed of the express train is 80 km/hr.

- 29. A bus covers a distance of 90 km at a uniform speed. Had the speed been 15 km/hour more it would have taken 30 minutes less for the journey. Find the original speed of the bus.**

Solution:

Let x be the original speed.

From the given data Time taken to cover the distance in

the original speed $T_1 = \frac{90}{x}$

Time taken to cover the same distance in the increased speed $T_2 = \frac{90}{x+15}$

Given that $T_1 - T_2 = \frac{1}{2}$

$$\frac{90}{x} - \frac{90}{x+15} = \frac{1}{2}$$

$$90 \left(\frac{1}{x} - \frac{1}{x+15} \right) = \frac{1}{2}$$

$$90 \left(\frac{x+15-x}{x(x+15)} \right) = \frac{1}{2}$$

$$90 \left(\frac{15}{x^2+15x} \right) = \frac{1}{2}$$

$$x^2 + 15x = 2700$$

$$x^2 + 15x - 2700 = 0$$

$$(x+60)(x-45) = 0$$

$x = -60$ is not admissible, So $x = 45$

\therefore The original Speed is 45 km /hr.

- 30. There is a square field whose side is 10 m. A square flower bed is prepared in its centre leaving a gravel path all round the flower bed. The total cost of laying the flower bed and gravelling the path at ₹3 and ₹4 per square metre respectively is ₹364. Find the width of the gravel path.**

Solution:

Let the length of side of flower bed is ' x '

The Area of flower bed = $A_1 = x^2$

Cost of laying the flower bed = $3x^2$

The length of the square land = 10m

Area of the square land = 100m

Area of the gravel path = $100 - x^2$

The cost of laying the gravel path

$$= 4(100 - x^2) = 400 - 4x^2$$

$$\therefore \text{The total cost} = 3x^2 + 400 - 4x^2 = 364$$

$$\Rightarrow 400 - 364 = x^2$$

$$x^2 = 36$$

$$\therefore x = 6$$

\therefore Hence the width of the gravel path

$$= \frac{10-x}{2} = \frac{10-6}{2} = 2\text{m}$$

- 31. If the roots of $(a - b)x^2 + (b - c)x + (c - a) = 0$ are real and equal, then prove that b, a, c are in arithmetic progression.**

Solution:

Given $(a - b)x^2 + (b - c)x + (c - a) = 0$.
 The roots are real and equal that is $\Delta = 0$.
 To prove that, b, a, c are in A.P
 $\Rightarrow 2a = b + c$.
 Here, $A = a - b$, $B = b - c$, $C = c - a$
 $b^2 - 4ac = 0$
 $\Rightarrow (b-c)^2 - 4(a-b)(c-a) = 0$
 $\Rightarrow b^2 + c^2 - 2bc - 4(ac - a^2 - bc + ab) = 0$
 $\Rightarrow b^2 + c^2 - 2bc - 4ac + 4a^2 + 4bc - 4ab = 0$
 $\Rightarrow (-2a)^2 + b^2 + c^2 - 4ab + 2bc - 4ac = 0$
 $\Rightarrow (-2a + b + c) = 0$
 $\Rightarrow -2a + b + c = 0 \Rightarrow 2a = b + c$.
 Hence the proof.

32. If a, b are real then show that the roots of the equation $(a - b)x^2 - 6(a + b)x - 9(a - b) = 0$ are real and unequal.

Solution:

Given $(a - b)x^2 - 6(a + b)x - 9(a - b) = 0$ and a, b are real.
 $\Delta = b^2 - 4ac$. $A = a - b$, $B = -6(a + b)$,
 $C = -9(a - b)$
 $\Delta = [-6(a+b)]^2 - 4(a-b)(-9(a-b))$
 $= 36(a^2 + 2ab + b^2) + 36(a^2 - 2ab + b^2)$
 $= 36(a^2 + 2ab + b^2 + a^2 - 2ab + b^2)$
 $= 36(2a^2 + 2b^2) = 72(a^2 + b^2)$
 a^2 and b^2 are always positive integers.
 $\therefore \Delta > 0$.
 Hence, the roots are real and unequal.

33. If the roots of the equation $(c^2 - ab)x^2 - 2(a^2 - bc)x + b^2 - ac = 0$ are real and equal prove that either $a = 0$ (or) $a^3 + b^3 + c^3 = 3abc$

Solution:

$(c^2 - ab)x^2 - 2(a^2 - bc)x + b^2 - ac = 0$
 $A = c^2 - ab$, $B = -2(a^2 - bc)$, $C = b^2 - ac$
 $\Delta = 0$
 $B^2 - 4AC = 0$.
 The roots are real and equal.
 $[-2(a^2 - bc)]^2 - 4[c^2 - ab][b^2 - ac] = 0$
 $4(a^2 - bc)^2 - 4(c^2 - ab)(b^2 - ac) = 0$
 $4[a^4 + b^2c^2 - 2a^2bc]$
 $- 4[b^2c^2 - ac^3 - ab^3 + a^2bc] = 0$
 $4[a^4 + b^2c^2 - 2a^2bc - b^2c^2$
 $+ ac^3 + ab^3 - a^2bc] = 0$
 $a^4 + ab^3 + ac^3 - 3a^2bc = 0$

$$a[a^3 + b^3 + c^3 - 3abc] = 0$$

$$a = 0 \text{ or } a^3 + b^3 + c^3 - 3abc = 0$$

$$\Rightarrow a^3 + b^3 + c^3 = 3abc$$

34. If the difference between the roots of the equation $x^2 - 13x + k = 0$ is 17 find k.

Solution:

$$x^2 - 13x + k = 0,$$

Here $a = 1$, $b = -13$, $c = k$

Let α , β be the roots of the equation, Then

$$\alpha + \beta = -\frac{b}{a} = \frac{-(-13)}{1} = 13 \quad \dots (1)$$

$$\text{Also } \alpha - \beta = 17 \quad \dots (2)$$

(1) + (2) we get, $2\alpha = 30$ gives $\alpha = 15$.

Therefore, $15 + \beta = 13$

(from (1)) gives $\beta = -2$

$$\text{But } \alpha\beta = \frac{c}{a} = \frac{k}{1},$$

$$15 \times (-2) = k \text{ we get, } k = -30$$

35. If α and β are the roots of $x^2 + 7x + 10 = 0$ find the values of

i) $\alpha - \beta$ ii) $\alpha^2 + \beta^2$ iii) $\alpha^3 - \beta^3$

iv) $\alpha^4 + \beta^4$ v) $\frac{\alpha}{\beta} + \frac{\beta}{\alpha}$ vi) $\frac{\alpha^2}{\beta} + \frac{\beta^2}{\alpha}$

Solution:

$$x^2 + 7x + 10 = 0$$

Here, $a = 1$, $b = 7$, $c = 10$

If α and β are the roots of the equation then

$$\alpha + \beta = -\frac{b}{a} = \frac{-7}{1} = -7$$

$$\alpha\beta = \frac{c}{a} = \frac{10}{1} = 10$$

$$\text{i) } (\alpha - \beta) = \sqrt{(\alpha + \beta)^2 - 4\alpha\beta}$$

$$= \sqrt{(-7)^2 - 4 \times 10} = \sqrt{9} = 3$$

$$\text{ii) } \alpha^2 + \beta^2 = (\alpha + \beta)^2 - 2\alpha\beta$$

$$= (-7)^2 - 2 \times 10 = 29$$

$$\text{iii) } \alpha^3 - \beta^3 = (\alpha - \beta)^3 + 3\alpha\beta(\alpha - \beta)$$

$$= (3)^3 + 3(10)(3) = 117$$

$$\text{iv) } \alpha^4 + \beta^4 = (\alpha^2 + \beta^2)^2 - 2\alpha^2\beta^2$$

(From (ii), $\alpha^2 + \beta^2 = 29$)
 Thus, $29^2 - 2 \times (10)^2 = 641$

$$\text{v) } \frac{\alpha}{\beta} + \frac{\beta}{\alpha} = \frac{\alpha^2 + \beta^2}{\alpha\beta} = \frac{(\alpha + \beta)^2 - 2\alpha\beta}{\alpha\beta}$$

$$= \frac{49 - 20}{10} = \frac{29}{10}$$

$$\begin{aligned} \text{vi) } \frac{\alpha^2}{\beta} + \frac{\beta^2}{\alpha} &= \frac{\alpha^3 + \beta^3}{\alpha\beta} \\ &= \frac{(\alpha + \beta)^3 - 3\alpha\beta(\alpha + \beta)}{\alpha\beta} \\ &= \frac{(-343) - 3(10 \times (-7))}{10} = \frac{-343 + 210}{10} \\ &= \frac{-133}{10} \end{aligned}$$

36. If α, β are the roots of the equation $3x^2 + 7x - 2 = 0$, find the values of

i) $\frac{\alpha}{\beta} + \frac{\beta}{\alpha}$ ii) $\frac{\alpha^2}{\beta} + \frac{\beta^2}{\alpha}$

Solution:

$$3x^2 + 7x - 2 = 0$$

$$\text{Here, } a = 3, b = 7, c = -2$$

Since α, β are the roots of the equation

$$\text{i) } \alpha + \beta = -\frac{b}{a} = \frac{-7}{3}$$

$$\alpha\beta = \frac{c}{a} = \frac{-2}{3}$$

$$\begin{aligned} \frac{\alpha}{\beta} + \frac{\beta}{\alpha} &= \frac{\alpha^2 + \beta^2}{\alpha\beta} = \frac{(\alpha + \beta)^2 - 2\alpha\beta}{\alpha\beta} \\ &= \frac{\left(\frac{-7}{3}\right)^2 - 2\left(\frac{-2}{3}\right)}{\frac{-2}{3}} = \frac{\frac{49}{9} + \frac{4}{3}}{\frac{-2}{3}} = \frac{49 + 12}{9} \\ &= \frac{61}{9} \times \frac{3}{-2} = \frac{-61}{6} \end{aligned}$$

$$\text{ii) } \frac{\alpha^2}{\beta} + \frac{\beta^2}{\alpha} = \frac{\alpha^3 + \beta^3}{\alpha\beta}$$

$$= \frac{(\alpha + \beta)^3 - 3\alpha\beta(\alpha + \beta)}{\alpha\beta}$$

$$= \frac{\left(\frac{-7}{3}\right)^3 - 3\left(\frac{-2}{3}\right)\left(\frac{-7}{3}\right)}{\frac{-2}{3}}$$

$$= \frac{\frac{-343}{27} - \frac{42}{9}}{\frac{-2}{3}} = \frac{-343 - 126}{27}$$

$$= \frac{217}{27} \times \frac{3}{-2}$$

$$= -\frac{469}{18}$$

37. Solve the following system of linear equations in three variables

$$\text{(i) } \frac{1}{x} - \frac{2}{y} + 4 = 0; \quad \frac{1}{y} - \frac{1}{z} + 1 = 0;$$

$$\frac{2}{z} + \frac{3}{x} = 14$$

$$\text{(ii) } x + 20 = \frac{3y}{2} = 2z + 5 = 110 - (y + z)$$

Solution:

$$\text{i) } \frac{1}{x} - \frac{2}{y} + 4 = 0 \dots\dots(1)$$

$$\frac{1}{y} - \frac{1}{z} + 1 = 0 \dots\dots(2)$$

$$\frac{2}{z} + \frac{3}{x} = 14 \dots\dots(3)$$

$$\text{Let } a = \frac{1}{x}, b = \frac{1}{y}, c = \frac{1}{z}$$

$$(1) \Rightarrow a - 2b = -4 \dots\dots(4)$$

$$(2) \Rightarrow b - c = -1 \dots\dots(5)$$

$$(3) \Rightarrow 3a + 2c = 14 \dots\dots(6)$$

From (4) & (5)

$$(4) \times 1 \Rightarrow a - 2b = -4$$

$$(5) \times 2 \Rightarrow 2b - 2c = -2 \quad (+)$$

$$\underline{\hspace{10em}} \\ a - 2c = -6 \dots\dots(7)$$

From (6) & (7)

$$(6) \times 1 \Rightarrow 3a + 2c = 14$$

$$(7) \times 3 \Rightarrow 3a - 6c = -18 \quad (-)$$

$$\underline{\hspace{10em}} \\ 8c = 32$$

$$c = 4$$

Substitute $c = 4$ in (5)

$$b - 4 + 1 = 0$$

$$b - 3 = 0$$

$$b = 3$$

Substitute $b = 3$ and $c = 4$ in (4)

$$a - 2b + 4 = 0$$

$$a - 2(3) + 4 = 0$$

$$a - 6 + 4 = 0$$

$$a - 2 = 0$$

$$a = 2$$

But if $a = 2, x = \frac{1}{2},$ if $b = 3, y = \frac{1}{3},$

$$\text{if } c = 3, z = \frac{1}{4}$$

$$\text{ii) } x + 20 = \frac{3y}{2} + 10$$

$$\Rightarrow 2x + 40 = 3y + 20$$

$$\begin{aligned} \Rightarrow 2x - 3y &= -20 \dots\dots(1) \\ \frac{3y}{2} + 10 &= 2z + 5 \\ \Rightarrow 3y + 20 &= 4z + 10 \\ \Rightarrow 3y - 4z &= -10 \dots\dots(2) \\ 2z + 5 &= 110 - (y+z) \\ \Rightarrow 2z + 5 &= 110 - y - z \\ y + 3z &= 105 \dots\dots(3) \end{aligned}$$

From (2)& (3)

$$(3) \times 3 \Rightarrow 3y + 9z = 315$$

$$(2) \times 1 \Rightarrow 3y - 4z = -10 \quad (-)$$

$$\hline 13z = 325$$

$$z = 25$$

Substitute $z = 25$ in (5)

$$y + 3(25) = 105$$

$$y + 75 = 105$$

$$y = 30$$

Substitute $y = 30$ in (1)

$$2x - 3(30) = -20$$

$$2x - 90 = -20$$

$$2x = 70 \Rightarrow x = 35$$

$$\therefore x = 35, y = 30, z = 25.$$

- 38. If α, β are the roots of the equation $2x^2 - x - 1 = 0$, then form the equation whose roots are (i) $\frac{1}{\alpha}, \frac{1}{\beta}$ (ii) $\alpha^2\beta, \beta^2\alpha$ (iii) $2\alpha + \beta, 2\beta + \alpha$**

Solution:

$$2x^2 - x - 1 = 0$$

$$\text{Here, } a = 2, b = -1, c = -1$$

$$\alpha + \beta = -\frac{b}{a} = \frac{-(-1)}{2} = \frac{1}{2}$$

$$\alpha\beta = \frac{c}{a} = -\frac{1}{2}$$

- i) Given roots are $\frac{1}{\alpha}, \frac{1}{\beta}$

$$\text{Sum of the roots} = \frac{1}{\alpha} + \frac{1}{\beta} = \frac{\alpha + \beta}{\alpha\beta}$$

$$= \frac{1}{-\frac{1}{2}} = -1$$

$$\text{Product of the roots} = \frac{1}{\alpha} \times \frac{1}{\beta} = \frac{1}{\alpha\beta}$$

$$= \frac{1}{-\frac{1}{2}} = -2$$

The required equation is, $x^2 - (\text{Sum of the roots})x + (\text{Product of the roots}) = 0$
 $x^2 - (-1)x - 2 = 0 \Rightarrow x^2 + x - 2 = 0$

- ii) $\alpha^2\beta, \beta^2\alpha$

$$\text{Sum of the roots} = \alpha^2\beta + \beta^2\alpha = \alpha\beta(\alpha + \beta)$$

$$= -\frac{1}{2} \left(\frac{1}{2} \right) = -\frac{1}{4}$$

$$\text{Product of the roots} = (\alpha^2\beta) \times (\beta^2\alpha) = (\alpha\beta)^3$$

$$= \left(-\frac{1}{2} \right)^3 = -\frac{1}{8}$$

The required equation is, $x^2 - (\text{Sum of the roots})x + (\text{Product of the roots}) = 0$

$$x^2 - \left(-\frac{1}{4} \right)x - \frac{1}{8} = 0 \Rightarrow 8x^2 + 2x - 1 = 0$$

- iii) $2\alpha + \beta, 2\beta + \alpha$

$$\text{Sum of the roots} = 2\alpha + \beta + 2\beta + \alpha$$

$$= 3(\alpha + \beta) = 3 \left(\frac{1}{2} \right) = \frac{3}{2}$$

Product of the roots

$$= (2\alpha + \beta) \times (2\beta + \alpha) = 4\alpha\beta + 2\alpha^2 + 2\beta^2 + \alpha\beta$$

$$= 5\alpha\beta + 2(\alpha^2 + \beta^2) = 5\alpha\beta + 2[(\alpha + \beta)^2 - 2\alpha\beta]$$

$$= 5 \left(-\frac{1}{2} \right) + 2 \left[\frac{1}{4} - 2 \times -\frac{1}{2} \right]$$

$$= -\frac{5}{2} + \left[\frac{1}{4} + 1 \right]$$

$$= -\frac{5}{2} + \frac{1}{2} + 2 = 0$$

The required equation is, $x^2 - (\text{Sum of the roots})x + (\text{Product of the roots}) = 0$

$$x^2 - \frac{3}{2}x + 0 = 0$$

$$\Rightarrow 2x^2 - 3x = 0$$

- 39. The roots of the equation $x^2 + 6x - 4 = 0$ are α, β . Find the quadratic equation whose roots are (i) α^2 and β^2 (ii) $\frac{2}{\alpha}$ and $\frac{2}{\beta}$ (iii) $\alpha^2\beta$ and $\beta^2\alpha$**

Solution:

- i) α^2 and β^2

$$x^2 + 6x - 4 = 0$$

$$a = 1, b = 6, c = -4$$

$$\alpha + \beta = -\frac{6}{1} = -6, \alpha\beta = \frac{-4}{1} = -4$$

Sum of the roots

$$\alpha^2 + \beta^2 = (\alpha + \beta)^2 - 2\alpha\beta$$

$$= (-6)^2 - 2(-4)$$

$$= 36 + 8$$

$$= 44$$

Product of the roots

$$\alpha^2\beta^2 = (\alpha\beta)^2 = (-4)^2 = 16$$

$$x^2 - (\text{Sum of the roots})x + (\text{Product of the roots}) = 0$$

$$\therefore x^2 - 44x + 16 = 0$$

ii) $\frac{2}{\alpha}$ and $\frac{2}{\beta}$

$$\text{Sum of the roots} = \frac{2}{\alpha} + \frac{2}{\beta} = \frac{2\alpha + 2\beta}{\alpha\beta}$$

$$= \frac{2(\alpha + \beta)}{\alpha\beta} = \frac{2(-6)}{-4} = \frac{-12}{-4} = 3$$

$$\text{Product of the roots} = \frac{2}{\alpha} \times \frac{2}{\beta} = \frac{4}{\alpha\beta}$$

$$= \frac{4}{-4} = -1$$

$$x^2 - (\text{Sum of the roots})x + (\text{Product of the roots}) = 0$$

$$\therefore x^2 - 3x - 1 = 0$$

iii) $\alpha^2\beta$ and $\beta^2\alpha$

$$\text{Sum of the roots} = \alpha^2\beta + \beta^2\alpha$$

$$= \alpha\beta(\alpha + \beta) = (-4)(-6) = 24$$

$$\text{Product of the roots} = (\alpha^2\beta)(\beta^2\alpha) = \alpha^3\beta^3$$

$$= (\alpha\beta)^3 = (-4)^3 = -64$$

$$x^2 - (\text{Sum of the roots})x + (\text{Product of the roots}) = 0$$

$$\therefore x^2 - 24x - 64 = 0$$

40. If α, β are the roots of $7x^2 + ax + 2 = 0$ and if $\beta - \alpha = \frac{-13}{7}$. Find the values of a . **MAY-22**

Solution:

$$7x^2 + ax + 2 = 0 \Rightarrow \alpha + \beta = \frac{-a}{7} \quad \dots (1)$$

$$\alpha\beta = \frac{2}{7}; \beta - \alpha = \frac{-13}{7}$$

$$\Rightarrow \alpha - \beta = \frac{13}{7} \quad \dots (2)$$

$$(\alpha - \beta)^2 = (\alpha + \beta)^2 - 4\alpha\beta$$

$$\left(\frac{13}{7}\right)^2 = \left(\frac{-a}{7}\right)^2 - 4\left(\frac{2}{7}\right)$$

$$\frac{169}{49} = \frac{a^2}{49} - \frac{8}{7}$$

$$\frac{169}{49} = \frac{a^2 - 56}{49}$$

$$a^2 - 56 = 169$$

$$a^2 = 225$$

$$\Rightarrow a = \pm 15$$

41. If one root of the equation $2y^2 - ay + 64 = 0$ is twice the other then find the values of a .

Solution:

$$2y^2 - ay + 64 = 0$$

$$\text{Here, } a = 2, b = -a, c = 64$$

$$\alpha + \beta = \dots (1)$$

$$\alpha\beta = \frac{64}{2} = 32 \quad \dots (2)$$

$$\text{Now, } \alpha = 2\beta$$

$$(2) \Rightarrow \alpha\beta = 32 \Rightarrow 2\beta^2 = 32$$

$$\Rightarrow \beta^2 = 16 \Rightarrow \beta = \pm 4$$

$$\text{Substitute } \beta = 4 \text{ in eqn (2)}$$

$$\Rightarrow 4\alpha = 32 \text{ then, } \alpha = 8,$$

$$\text{Substitute } \beta = -4 \text{ in eqn (2)}$$

$$\Rightarrow -4\alpha = 32 \text{ then, } \alpha = -8,$$

$$(1) \Rightarrow 4 + 8 = \frac{a}{2}$$

$$\Rightarrow 12 = \frac{a}{2}$$

$$a = 24$$

$$\therefore a = 24 \text{ and } a = -24$$

42. If one root of the equation $3x^2 + kx + 81 = 0$ (having real roots) is the square of the other then find k .

Solution:

$$\text{Given } 3x^2 + kx + 81 = 0$$

$$\text{Here } a = 3, b = k, c = 81$$

$$\alpha + \beta = -\frac{k}{3} \quad \dots (1)$$

$$\alpha\beta = 27 \quad \dots (2)$$

$$\text{But } \alpha = \beta^2$$

$$\text{From equation (2)}$$

$$\beta^3 = 27$$

$$\beta = 3$$

$$\therefore \alpha = 9$$

$$(1) \Rightarrow 9 + 3 = -\frac{k}{3} \Rightarrow 12 = -\frac{k}{3}$$

$$k = -36$$

43. Find X and Y if $X + Y = \begin{pmatrix} 7 & 0 \\ 3 & 5 \end{pmatrix}$ and

$$X - Y = \begin{pmatrix} 3 & 0 \\ 0 & 4 \end{pmatrix}$$

Solution:

$$X + Y = \begin{pmatrix} 7 & 0 \\ 3 & 5 \end{pmatrix} \quad \dots (1) \text{ and}$$

$$X - Y = \begin{pmatrix} 3 & 0 \\ 0 & 4 \end{pmatrix} \quad \dots (2)$$

$$(1) + (2) \Rightarrow 2X = \begin{pmatrix} 10 & 0 \\ 3 & 9 \end{pmatrix}$$

$$\therefore X = \begin{pmatrix} 5 & 0 \\ \frac{3}{2} & \frac{9}{2} \end{pmatrix}$$

$$(1) \Rightarrow Y = \begin{pmatrix} 7 & 0 \\ 3 & 5 \end{pmatrix} - \begin{pmatrix} 5 & 0 \\ \frac{3}{2} & \frac{9}{2} \end{pmatrix} = \begin{pmatrix} 2 & 0 \\ \frac{3}{2} & \frac{1}{2} \end{pmatrix}$$

44. Find x and y if $x \begin{pmatrix} 4 \\ -3 \end{pmatrix} + y \begin{pmatrix} -2 \\ 3 \end{pmatrix} = \begin{pmatrix} 4 \\ 6 \end{pmatrix}$

Solution:

$$x \begin{pmatrix} 4 \\ -3 \end{pmatrix} + y \begin{pmatrix} -2 \\ 3 \end{pmatrix} = \begin{pmatrix} 4 \\ 6 \end{pmatrix}$$

$$\Rightarrow \begin{pmatrix} 4x \\ -3x \end{pmatrix} + \begin{pmatrix} -2y \\ 3y \end{pmatrix} = \begin{pmatrix} 4 \\ 6 \end{pmatrix}$$

$$\Rightarrow \begin{pmatrix} 4x - 2y \\ -3x + 3y \end{pmatrix} = \begin{pmatrix} 4 \\ 6 \end{pmatrix}$$

$$4x - 2y = 4 \Rightarrow 2x - y = 2 \quad \dots (1)$$

$$-3x + 3y = 6 \Rightarrow -x + y = 2 \quad \dots (2)$$

$$(1) + (2) \Rightarrow x = 4,$$

$$(2) \Rightarrow -4 + y = 2$$

$$y = 6$$

45. Find the non-zero values of x satisfying the matrix equation

$$x \begin{pmatrix} 2x & 2 \\ 3 & x \end{pmatrix} + 2 \begin{pmatrix} 8 & 5x \\ 4 & 4x \end{pmatrix} = \begin{pmatrix} x^2 + 8 & 24 \\ 10 & 6x \end{pmatrix}$$

Solution:

$$x \begin{pmatrix} 2x & 2 \\ 3 & x \end{pmatrix} + 2 \begin{pmatrix} 8 & 5x \\ 4 & 4x \end{pmatrix} = 2 \begin{pmatrix} x^2 + 8 & 24 \\ 10 & 6x \end{pmatrix}$$

$$\Rightarrow \begin{pmatrix} 2x^2 & 2x \\ 3x & x^2 \end{pmatrix} + \begin{pmatrix} 16 & 10x \\ 8 & 8x \end{pmatrix} = 2 \begin{pmatrix} 2x^2 + 16 & 48 \\ 20 & 12x \end{pmatrix}$$

$$\Rightarrow \begin{pmatrix} 2x^2 + 16 & 12x \\ 3x + 8 & x^2 + 8x \end{pmatrix} = 2 \begin{pmatrix} 2x^2 + 16 & 48 \\ 20 & 12x \end{pmatrix}$$

$$\therefore 12x = 48 \Rightarrow x = 4$$

$$3x + 8 = 20 \Rightarrow 3x = 12 \Rightarrow x = 4$$

$$x^2 + 8x = 12x$$

$$\Rightarrow x^2 - 4x = 0$$

$$\Rightarrow x(x - 4) = 0,$$

$$x = 0, x = 4$$

$$\therefore x = 4$$

46. Solve for x, y $\begin{pmatrix} x^2 \\ y^2 \end{pmatrix} + 2 \begin{pmatrix} -2x \\ -y \end{pmatrix} = \begin{pmatrix} 5 \\ 8 \end{pmatrix}$

Solution:

$$\begin{pmatrix} x^2 \\ y^2 \end{pmatrix} + 2 \begin{pmatrix} -2x \\ -y \end{pmatrix} = \begin{pmatrix} 5 \\ 8 \end{pmatrix}$$

$$\begin{pmatrix} x^2 + (-4x) \\ y^2 + (-2y) \end{pmatrix} = \begin{pmatrix} 5 \\ 8 \end{pmatrix}$$

$$\Rightarrow x^2 - 4x - 5 = 0 \quad \dots (1)$$

$$y^2 - 2y - 8 = 0 \quad \dots (2)$$

$$(1) \Rightarrow (x-5)(x+1) = 0 \quad (\because \text{By Factorization})$$

$$\therefore x = 5, x = -1$$

$$(2) \Rightarrow (y-4)(y+2) = 0 \quad (\because \text{By Factorization})$$

$$\therefore y = 4, y = -2$$

47. If $A = \begin{pmatrix} 1 & -1 \\ 2 & 1 \\ 1 & 3 \end{pmatrix}$, $B = \begin{pmatrix} 1 & -1 \\ 2 & 1 \\ 1 & 3 \end{pmatrix}$ and $C = \begin{pmatrix} 1 & 2 \\ 2 & -1 \end{pmatrix}$

show that $(AB)C = A(BC)$.

Solution:

$$AB = \begin{pmatrix} 1 & -1 \\ 2 & 1 \\ 1 & 3 \end{pmatrix} \begin{pmatrix} 1 & -1 \\ 2 & 1 \\ 1 & 3 \end{pmatrix}$$

$$= \begin{pmatrix} 1-2+2 & -1-1+6 \\ 1-2+2 & -1-1+6 \end{pmatrix}$$

$$= \begin{pmatrix} 1 & 4 \\ 1 & 4 \end{pmatrix}$$

$$(AB)C = \begin{pmatrix} 1 & 4 \\ 1 & 4 \end{pmatrix} \begin{pmatrix} 1 & 2 \\ 2 & -1 \end{pmatrix}$$

$$= \begin{pmatrix} 1+8 & 2-4 \\ 1+8 & 2-4 \end{pmatrix}$$

$$= \begin{pmatrix} 9 & -2 \\ 9 & -2 \end{pmatrix}$$

$$BC = \begin{pmatrix} 1 & -1 \\ 2 & 1 \\ 1 & 3 \end{pmatrix} \begin{pmatrix} 1 & 2 \\ 2 & -1 \end{pmatrix}$$

$$= \begin{pmatrix} 1-2 & 2+1 \\ 2+2 & 4-1 \\ 1+6 & 2-3 \end{pmatrix} = \begin{pmatrix} -1 & 3 \\ 4 & 3 \\ 7 & -1 \end{pmatrix}$$

$$A(BC) = \begin{pmatrix} 1 & -1 \\ 2 & 1 \\ 1 & 3 \end{pmatrix} \begin{pmatrix} -1 & 3 \\ 4 & 3 \\ 7 & -1 \end{pmatrix}$$

$$= \begin{pmatrix} -1-4+14 & 3-3-2 \\ -1-4+14 & 3-3-2 \end{pmatrix}$$

$$= \begin{pmatrix} 9 & -2 \\ 9 & -2 \end{pmatrix}$$

$$\therefore \text{LHS} = \text{RHS}$$

48. Let $A = \begin{pmatrix} 4 & 0 \\ 1 & 5 \end{pmatrix}$, $B = \begin{pmatrix} 2 & 0 \\ 1 & 2 \end{pmatrix}$

Show that (i) $A(BC) = (AB)C$

$$(ii) (A-B)C = AC - BC$$

$$(iii) (A-B)^T = A^T - B^T$$

Solution:

$$A = \begin{pmatrix} 1 & 2 \\ 1 & 3 \end{pmatrix}, B = \begin{pmatrix} 4 & 0 \\ 1 & 5 \end{pmatrix}, C = \begin{pmatrix} 2 & 0 \\ 1 & 2 \end{pmatrix}$$

$$i) A(BC) = (AB)C$$

$$BC = \begin{pmatrix} 4 & 0 \\ 1 & 5 \end{pmatrix} \times \begin{pmatrix} 2 & 0 \\ 1 & 2 \end{pmatrix} = \begin{pmatrix} 8 & 0 \\ 7 & 10 \end{pmatrix}$$

$$\begin{aligned} A(BC) &= \begin{pmatrix} 1 & 2 \\ 1 & 3 \end{pmatrix} \times \begin{pmatrix} 8 & 0 \\ 7 & 10 \end{pmatrix} \\ &= \begin{pmatrix} 8+14 & 0+20 \\ 8+21 & 0+30 \end{pmatrix} \\ &= \begin{pmatrix} 22 & 20 \\ 29 & 30 \end{pmatrix} \text{-----(1)} \end{aligned}$$

$$\begin{aligned} AB &= \begin{pmatrix} 1 & 2 \\ 1 & 3 \end{pmatrix} \times \begin{pmatrix} 4 & 0 \\ 1 & 5 \end{pmatrix} \\ &= \begin{pmatrix} 4+2 & 0+10 \\ 4+3 & 0+15 \end{pmatrix} = \begin{pmatrix} 6 & 10 \\ 7 & 15 \end{pmatrix} \end{aligned}$$

$$\begin{aligned} (AB)C &= \begin{pmatrix} 6 & 10 \\ 7 & 15 \end{pmatrix} \times \begin{pmatrix} 2 & 0 \\ 1 & 2 \end{pmatrix} \\ &= \begin{pmatrix} 12+10 & 0+20 \\ 14+15 & 0+30 \end{pmatrix} \\ &= \begin{pmatrix} 22 & 20 \\ 29 & 30 \end{pmatrix} \text{-----(2)} \end{aligned}$$

$$(1), (2) \Rightarrow A(BC) = (AB)C$$

$$ii) (A-B)C = AC - BC$$

$$(A-B) = \begin{pmatrix} -3 & 2 \\ 0 & -2 \end{pmatrix}$$

$$\begin{aligned} (A-B)C &= \begin{pmatrix} -3 & 2 \\ 0 & -2 \end{pmatrix} \times \begin{pmatrix} 2 & 0 \\ 1 & 2 \end{pmatrix} \\ &= \begin{pmatrix} -6+2 & 0+4 \\ 0-2 & 0-4 \end{pmatrix} \\ &= \begin{pmatrix} -4 & 4 \\ -2 & -4 \end{pmatrix} \text{-----(1)} \end{aligned}$$

$$\begin{aligned} AC &= \begin{pmatrix} 1 & 2 \\ 1 & 3 \end{pmatrix} \times \begin{pmatrix} 2 & 0 \\ 1 & 2 \end{pmatrix} \\ &= \begin{pmatrix} 2+2 & 0+4 \\ 2+3 & 0+6 \end{pmatrix} = \begin{pmatrix} 4 & 4 \\ 5 & 6 \end{pmatrix} \end{aligned}$$

$$BC = \begin{pmatrix} 4 & 0 \\ 1 & 5 \end{pmatrix} \times \begin{pmatrix} 2 & 0 \\ 1 & 2 \end{pmatrix}$$

$$= \begin{pmatrix} 8+0 & 0+0 \\ 2+5 & 0+10 \end{pmatrix} = \begin{pmatrix} 8 & 0 \\ 7 & 10 \end{pmatrix}$$

$$\begin{aligned} AC - BC &= \begin{pmatrix} 4 & 4 \\ 5 & 6 \end{pmatrix} - \begin{pmatrix} 8 & 0 \\ 7 & 10 \end{pmatrix} \\ &= \begin{pmatrix} -4 & 4 \\ -2 & -4 \end{pmatrix} \text{-----(2)} \end{aligned}$$

$$(1), (2) \Rightarrow (A-B)C = AC - BC$$

$$iii) (A-B)^T = A^T - B^T$$

$$A-B = \begin{pmatrix} -3 & 2 \\ 0 & -2 \end{pmatrix}$$

$$\Rightarrow (A-B)^T = \begin{pmatrix} -3 & 0 \\ 2 & -2 \end{pmatrix}$$

$$A^T = \begin{pmatrix} 1 & 1 \\ 2 & 3 \end{pmatrix}, B^T = \begin{pmatrix} 4 & 1 \\ 0 & 5 \end{pmatrix}$$

$$A^T - B^T = \begin{pmatrix} -3 & 0 \\ 2 & -2 \end{pmatrix}$$

$$(1), (2) \Rightarrow (A-B)^T = A^T - B^T$$

$$49. \text{ If } A = \begin{pmatrix} a & b \\ c & d \end{pmatrix} \text{ and } I = \begin{pmatrix} 1 & 0 \\ 0 & 1 \end{pmatrix}$$

show that $A^2 - (a+d)A = (bc - ad)I_2$

Solution:

$$A = \begin{pmatrix} a & b \\ c & d \end{pmatrix}, I = \begin{pmatrix} 1 & 0 \\ 0 & 1 \end{pmatrix}$$

$$\begin{aligned} A^2 &= \begin{pmatrix} a & b \\ c & d \end{pmatrix} \times \begin{pmatrix} a & b \\ c & d \end{pmatrix} \\ &= \begin{pmatrix} a^2+bc & ab+bd \\ ac+cd & bc+d^2 \end{pmatrix} \end{aligned}$$

$$\begin{aligned} A^2 - (a+d)A &= \begin{pmatrix} a^2+bc & ab+bd \\ ac+cd & bc+d^2 \end{pmatrix} - (a+d) \begin{pmatrix} a & b \\ c & d \end{pmatrix} \\ &= \begin{pmatrix} a^2+bc & ab+bd \\ ac+cd & bc+d^2 \end{pmatrix} \end{aligned}$$

$$= \begin{pmatrix} a^2+bc & ab+bd \\ ac+cd & bc+d^2 \end{pmatrix} - \begin{pmatrix} a^2+ad & ab+bd \\ ac+cd & ad+d^2 \end{pmatrix}$$

$$= \begin{pmatrix} bc-ad & 0 \\ 0 & bc-ad \end{pmatrix}$$

$$= (bc-ad) \begin{pmatrix} 1 & 0 \\ 0 & 1 \end{pmatrix} = (bc-ad)I$$

4

Geometry

2 Marks

STAGE 2

1. Show that $\Delta PST \sim \Delta PQR$

Solution:

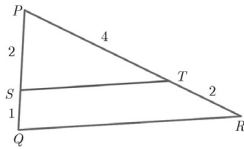
(i) In ΔPST and ΔPQR ,

$$\frac{PS}{PQ} = \frac{2}{2+1} = \frac{2}{3},$$

$$\frac{PT}{PR} = \frac{4}{4+2} = \frac{2}{3}$$

Thus, $\frac{PS}{PQ} = \frac{PT}{PR}$ and $\angle P$ is common

Therefore, by SAS similarity,

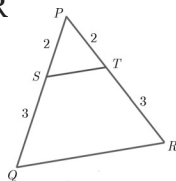
 $\Delta PST \sim \Delta PQR$ (ii) In ΔPST and ΔPQR

$$\frac{PS}{PQ} = \frac{2}{2+3} = \frac{2}{5}, \quad \frac{PT}{PR} = \frac{2}{2+3} = \frac{2}{5}$$

Thus, $\frac{PS}{PQ} = \frac{PT}{PR}$ and $\angle P$ is common.

Therefore, by SAS similarity

 $\Delta PST \sim \Delta PQR$ 2. Is $\Delta ABC \sim \Delta PQR$?

Solution:

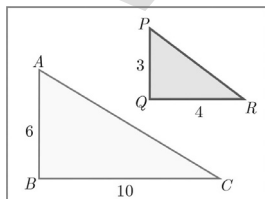
In ΔABC and ΔPQR

$$\frac{PQ}{AB} = \frac{3}{6} = \frac{1}{2}, \quad \frac{QR}{BC} = \frac{4}{10} = \frac{2}{5}$$

Since $\frac{1}{2} \neq \frac{2}{5}$, $\frac{PQ}{AB} \neq \frac{QR}{BC}$

The corresponding sides are not proportional.

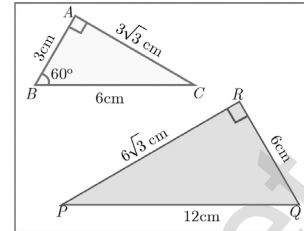
Therefore ΔABC is not similar to ΔPQR 3. Observe Figures and find $\angle P$.

Solution:

In ΔBAC and ΔPRQ ,

$$\frac{AB}{RQ} = \frac{3}{6} = \frac{1}{2}, \quad \frac{BC}{QP} = \frac{6}{12} = \frac{1}{2}$$

$$\frac{CA}{PR} = \frac{3\sqrt{3}}{6\sqrt{3}} = \frac{1}{2}$$

Therefore, $\frac{AB}{RQ} = \frac{BC}{QP} = \frac{CA}{PR}$

By SSS similarity,

we have $\Delta BAC \sim \Delta QRP$ $\angle P = \angle C$ (Since the corresponding parts of similar triangle)

$$\angle P = \angle C = 180^\circ - (\angle A + \angle B)$$

$$= 180^\circ - (90^\circ + 60^\circ)$$

$$\angle P = 180^\circ - 150^\circ = 30^\circ$$

4. A boy of height 90cm is walking away from the base of a lamp post at a speed of 1.2m/sec. If the lamppost is 3.6m above the ground, find the length of his shadow cast after 4 seconds.

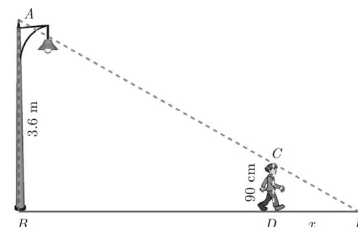

Solution:

Speed = 1.2 m/s

Time = 4 seconds

Distance = Speed \times Time

$$= 1.2 \times 4 = 4.8 \text{ m} = BD$$

Let x be the length of the shadow after 4 secondsSince, $\Delta ABE \sim \Delta CDE$, $\frac{BE}{DE} = \frac{AB}{CD}$

$$\text{gives } \frac{4.8+x}{x} = \frac{3.6}{0.9} = 4$$

$$4.8+x = 4x \text{ gives } 3x = 4.8, \text{ so, } x = 1.6 \text{ m.}$$

The length of his shadow DE = 1.6m

5. In Figure $\angle A = \angle CED$ prove that $\triangle CAB \sim \triangle CED$. Also find the value of x .

Solution:

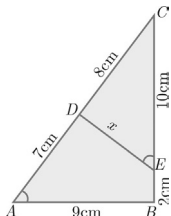

In Figure $\triangle CAB$ and $\triangle CED$, $\angle C$ is common,

$$\angle A = \angle CED$$

Therefore, $\triangle CAB \sim \triangle CED$ (BY AA similarity)

$$\text{Hence, } \frac{CA}{CE} = \frac{AB}{DE} = \frac{CB}{CD}$$

$$\frac{AB}{DE} = \frac{CB}{CD} \text{ gives, } \frac{9}{x} = \frac{10+2}{8}$$

$$\text{So, } x = \frac{8 \times 9}{12} = 6 \text{ cm.}$$

6. In Figure, QA and PB are perpendiculars to AB. If AO = 10 cm, BO = 6 cm and PB = 9 cm. Find AQ.

Solution:

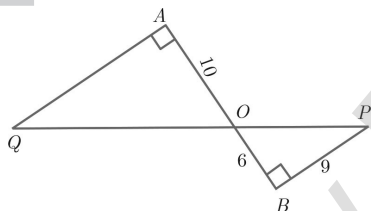

In $\triangle AOQ$ and $\triangle BOP$, $\angle OAQ = \angle OBP = 90^\circ$

$$\angle AOQ = \angle BOP \text{ (Vertically opposite angles)}$$

Therefore, by AA criterion of similarity,

$$\triangle AOQ \sim \triangle BOP$$

$$\frac{AO}{BO} = \frac{OQ}{OP} = \frac{AQ}{BP}$$

$$\frac{10}{6} = \frac{AQ}{9} \text{ gives } AQ = \frac{10 \times 9}{6} = 15 \text{ cm}$$

7. The perimeters of two similar triangles ABC and PQR are respectively 36 cm and 24 cm. If PQ = 10 cm, find AB.

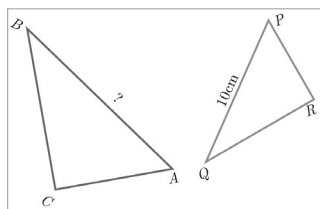

Solution:

The ratio of the corresponding sides of similar triangles is same as the ratio of their perimeters.

Since, $\triangle ABC \sim \triangle PQR$

$$\frac{AB}{PQ} = \frac{BC}{QR} = \frac{AC}{PR} = \frac{36}{24}$$

$$\frac{AB}{PQ} = \frac{36}{24} \text{ gives } \frac{AB}{10} = \frac{36}{24}$$

$$AB = \frac{36 \times 10}{24} = 15 \text{ cm.}$$

8. In $\triangle ABC$, if $DE \parallel BC$, $AD = x$, $DB = x - 2$, $AE = x + 2$ and $EC = x - 1$ then find the lengths of the sides AB and AC.

Solution:

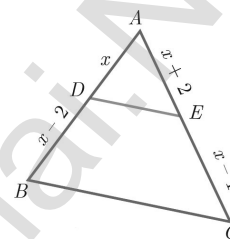

In $\triangle ABC$ we have $DE \parallel BC$

By Thales theorem, we have $\frac{AD}{DB} = \frac{AE}{EC}$

$$\frac{x}{x-2} = \frac{x+2}{x-1} \text{ gives } x(x-1) = (x-2)(x+2)$$

$$\text{Hence, } x^2 - x = x^2 - 4, \text{ So } x = 4.$$

$$\text{When } x = 4, AD = 4, DB = x - 2 = 2,$$

$$AE = x + 2 = 6, EC = x - 1 = 3$$

$$\text{Hence, } AB = AD + DB = 4 + 2 = 6$$

$$AC = AE + EC = 6 + 3 = 9$$

Therefore $AB = 6$, $AC = 9$.

9. What length of ladder is needed to reach a height of 7 ft along the wall when the base of the ladder is 4 ft from the wall? Round off your answer to the next tenth place.

Solution:

Let x be the length of the ladder.

$$BC = 4 \text{ ft.}$$

$$AC = 7 \text{ ft.}$$

By Pythagoras Theorem we have,

$$AB^2 = AC^2 + BC^2$$

$$x^2 = 7^2 + 4^2 \text{ gives } x^2 = 49 + 16$$

$$x^2 = 65$$

$$\text{Hence } x = \sqrt{65}$$

$$= 8.1$$

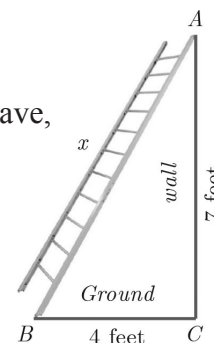

Therefore the length of the ladder is approximately 8.1 ft.

10. In the Figure, $DE \parallel AC$ and $DC \parallel AP$.

Prove that $\frac{BE}{EC} = \frac{BC}{CP}$

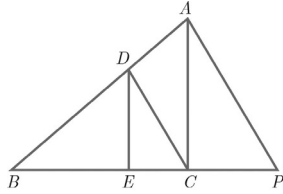

Solution:

In $\triangle BPA$, $DC \parallel AP$, By Basic Proportionality Theorem

we get, $\frac{BC}{CP} = \frac{BD}{DA}$ -----(1)

In $\triangle BCA$, $DE \parallel AC$, By Basic Proportionality Theorem

we get, $\frac{BE}{EC} = \frac{BD}{DA}$ -----(2)

From (1) and (2) $\frac{BE}{EC} = \frac{BC}{CP}$. Hence Proved

11. A man goes 18 m due east and then 24 m due north. Find the distance of his current position from the starting point?

Solution:

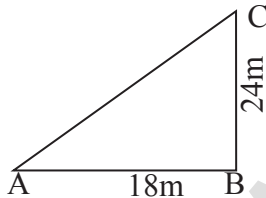

In $\triangle ABC$, $AC^2 = AB^2 + BC^2$

$$AC^2 = (18)^2 + (24)^2 = 324 + 576$$

$$AC^2 = 900$$

$$AC = \sqrt{900}$$

$$AC = 30 \text{ m}$$

\therefore The distance from the starting point is 30 m

12. There are two paths that one can choose to go from Sarah's house to James house. One way is to take C street, and the other way requires to take B street and then A street. How much shorter is the direct path along C street? (Using figure).

Solution:

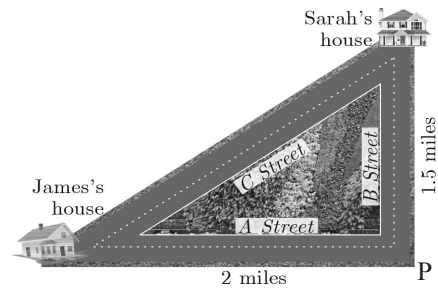

While Going through Street C,

$$\begin{aligned} SJ &= \sqrt{(1.5)^2 + (2)^2} \\ &= \sqrt{2.25 + 4} = \sqrt{6.25} \\ &= 2.5 \text{ miles} \end{aligned}$$

If one chooses A street and B street he has to go $SP + PJ = 1.5 + 2 = 3.5$ miles

Required Shorter Distance along

$$C \text{ street} = 3.5 - 2.5 = 1 \text{ mile}$$

13. To get from point A to point B you must avoid walking through a pond. You must walk 34 m south and 41 m east. To the nearest meter, how many meters would be saved if it were possible to make a way through the pond?

Solution:

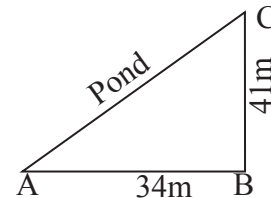

To make a Straight way through the pond

$$\begin{aligned} AC^2 &= AB^2 + BC^2 \\ &= (34)^2 + (41)^2 \\ &= 1156 + 1681 = 2837 \end{aligned}$$

$$AC^2 = 2837 \Rightarrow AC = \sqrt{2837} = 53.26 \text{ m}$$

Through C one must walk

$$\begin{aligned} AC &= AB + BC \\ &= 34 + 41 = 75 \text{ m} \end{aligned}$$

walking through a pond one must come only 53.26m.

The difference is $(75 - 53.26) \text{ m} = 21.74 \text{ m}$

To the nearest, one can save 21.74 m

14. Find the length of the tangent drawn from a point whose distance from the centre of a circle is 5 cm and radius of the circle is 3 cm.

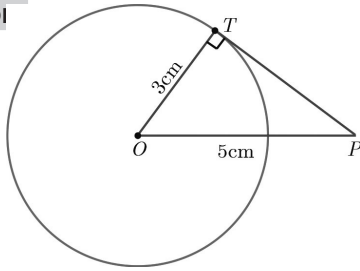
Solution:

Given $OP = 5$ cm, radius $r = 3$ cm

To find the length of tangent PT .

In right angled Triangle OTP

$$OP^2 = OT^2 + PT^2$$

(By Pythagoras Theorem)

$$5^2 = 3^2 + PT^2$$

$$PT^2 = 25 - 9 = 16$$

Length of the tangent $PT = 4$ cm.

15. In Figure, O is the centre of a circle. PQ is a chord and the tangent PR at P makes an angle of 50° with PQ . Find $\angle POQ$.

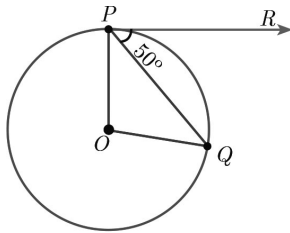
**Solution:**

$$\angle OPQ = 90^\circ - 50^\circ = 40^\circ$$

(Angle between the radius and tangent is 90°)

$OP = OQ$ (Radii of a circle are equal)

$\angle OPQ = \angle OQP = 40^\circ$ ($\triangle OPQ$) is isosceles

$$\angle POQ = 180^\circ - \angle OPQ - \angle OQP$$

$$\angle POQ = 180^\circ - 40^\circ - 40^\circ = 100^\circ$$

16. In Figure, $\triangle ABC$ is circumscribing a circle. Find the length of BC .

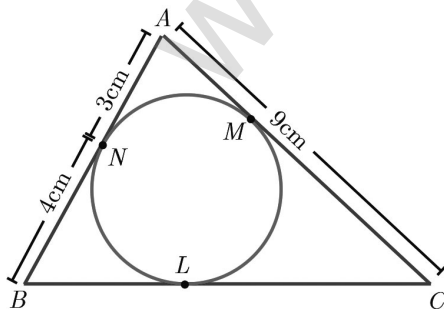
**Solution:**

$$AN = AM = 3$$
 cm

(Tangents drawn from same external point are equal)

$$BN = BL = 4$$
 cm

$$CL = CM = AC - AM$$

$$= 9 - 3 = 6$$
 cm

$$BC = BL + CL$$

$$= 4 + 6$$

$$= 10$$
 cm

17. If radii of two concentric circles are 4cm and 5cm then find the length of the chord of one circle which is a tangent to the other circle.

Solution:

$$OA = 4$$
 cm,

$$OB = 5$$
 cm,

also $OA \perp BC$

$$OB^2 = OA^2 + AB^2$$

$$5^2 = 4^2 + AB^2$$

$$AB^2 = 25 - 16 = 9$$

Therefore $AB = 3$ cm, $BC = 2AB$

hence, $BC = 2 \times 3 = 6$ cm

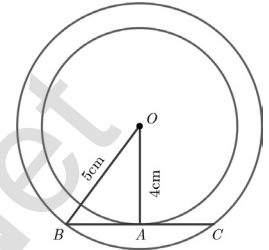

18. CEVA'S Theorem

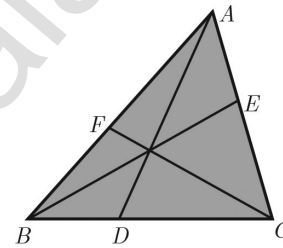
**Statement:**

Let ABC be a triangle and let D, E, F be points on lines BC, CA, AB respectively.

Then the cevians AD, BE, CF are concurrent

if and only if $\frac{BD}{DC} \times \frac{CE}{EA} \times \frac{AF}{FB} = 1$

where the lengths are directed.

This also works for the reciprocal of each of the ratios as the reciprocal of 1 is 1.

19. MENELAUS Theorem (Without Proof)

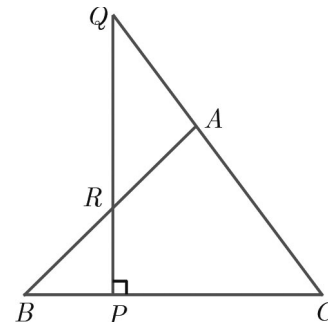
**Statement:**

A necessary and sufficient condition for points P, Q, R on the respective sides BC, CA, AB

(or their extension) of a triangle ABC to be collinear is that

$\frac{BP}{PC} \times \frac{CQ}{QA} \times \frac{AR}{RB} = -1$ where all segments in the formula are directed segments.

20. The length of the tangent to a circle from a point P, which is 25 cm away from the centre is 24 cm. What is the radius of the circle?

Solution:

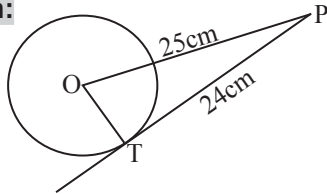

From the figure, $r = \sqrt{OP^2 - AP^2}$
 $= \sqrt{25^2 - 24^2}$
 $= \sqrt{625 - 576}$
 $= \sqrt{49}$
 $r = 7\text{cm}$

21. PQ is a tangent drawn from a point P to a circle with centre O and QOR is a diameter of the circle such that $\angle POR = 120^\circ$. Find $\angle OPQ$.

Solution:

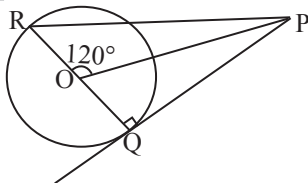

From the given, we have the figure.

$$\angle ROQ = 180^\circ$$

Given, $\angle ROP = 120^\circ$

$$\therefore \angle POQ = 60^\circ$$

($\because \angle ROQ = \angle ROP + \angle POQ$)

$$\angle POQ + \angle OQP + \angle QPO = 180^\circ$$

(From triangle property)

$$\text{then, } 60^\circ + 90^\circ + \angle QPO = 180^\circ$$

($\angle OQP = 90^\circ$ from tangents property)

$$150^\circ + \angle QPO = 180^\circ$$

$$\angle QPO = 30^\circ.$$

Hence $\angle OPQ = 30^\circ$

22. A tangent ST to a circle touches it at B. AB is a chord such that $\angle ABT = 65^\circ$. Find $\angle AOB$, where "O" is the centre of the circle.

Solution:

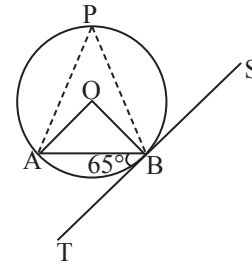

From the figure

$\angle OBT = 90^\circ$ (\because OB radius, BT tangent)

$$\therefore \angle OBA = 90^\circ - 65^\circ = 25^\circ$$

and $\angle OAB = 25^\circ$

(\because OA = OB, then $\angle OBA = \angle OAB$)

$$\therefore \angle AOB = 180^\circ - (\angle OAB + \angle OBA)$$

$$= 180^\circ - 50^\circ$$

$$\angle AOB = 130^\circ$$

23. In two concentric circles, a chord of length 16 cm of larger circle becomes a tangent to the smaller circle whose radius is 6 cm. Find the radius of the larger circle.

Solution:

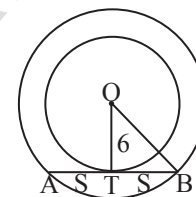

AB = 16 cm and OC = 6 cm

But $OC \perp AB$ and C is divided into two equal parts (\because by circles theorem)

then, AC = CB = 8 cm

To find OB. (OB is radius of larger circle)

By Pythagoras,

$$OB = \sqrt{OC^2 + BC^2}$$

$$= \sqrt{6^2 + 8^2}$$

$$= \sqrt{36 + 64}$$

OB = 10 cm

24. An artist has created a triangular stained glass window and has one strip of small length left before completing the window. She needs to figure out the length of left out portion based on the lengths of the other sides as shown in the figure.

Solution:

From the figure,

AE = 3 cm,

BF = x,

BD = 3 cm, EC = 4 cm,

$$FA = 5 \text{ cm,}$$

$$CD = 10 \text{ cm}$$

By Ceva's Theorem ,

$$\frac{BF}{FA} \times \frac{CD}{DB} \times \frac{AE}{EC} = 1$$

$$\Rightarrow \frac{x}{5} \times \frac{10}{3} \times \frac{3}{4} = 1$$

$$\frac{x}{2} = 1$$

$$x = 2 \text{ cm}$$

Hence, the required is 2 cm.

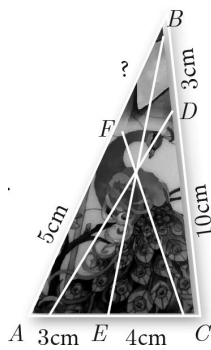

$$l = h \left(\frac{a+b}{ab} \right). \text{ Therefore, } h = \frac{ab}{a+b}$$

Hence, the height of the intersection of the lines joining the top of each pole to the foot of the opposite pole is $\frac{ab}{a+b}$ metres.

2. An insect 8 m away initially from the foot of a lamp post which is 6 m tall, crawls towards it moving through a distance. If its distance from the top of the lamp post is equal to the distance it has moved, how far is the insect away from the foot of the lamp post?

Solution:

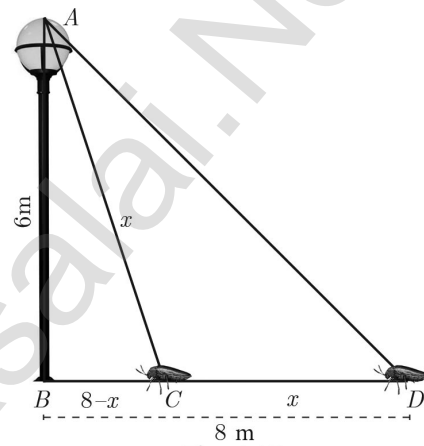

Distance between the insect and the foot of the lamp post $BD = 8 \text{ m}$.

The height of the lamp post, $AB = 6 \text{ m}$.

After moving a distance of $x \text{ m}$, let the insect be at C.

Let, $AC = CD = x$.

Then $BC = BD - CD = 8 - x$

In $\triangle ABC$, $\angle B = 90^\circ$

$$AC^2 = AB^2 + BC^2 \text{ gives } x^2 = 6^2 + (8 - x)^2$$

$$x^2 = 36 + 64 - 16x + x^2$$

$$16x = 100, x = 6.25$$

Then $BC = 8 - x$

$$= 8 - 6.25 = 1.75 \text{ m}$$

Therefore, the insect is 1.75 m away from the foot of the lamp post.

3. P and Q are the mid-points of the sides CA and CB respectively of a $\triangle ABC$, right angled at C. Prove that $4(AQ^2 + BP^2) = 5AB^2$.

5 Marks

STAGE 2

1. Two poles of height 'a' metres and 'b' metres are 'p' metres apart. Prove that the height of the point of intersection of the lines joining the top of each pole to the foot of the opposite pole is given by $\frac{ab}{a+b}$ metres.

Solution:

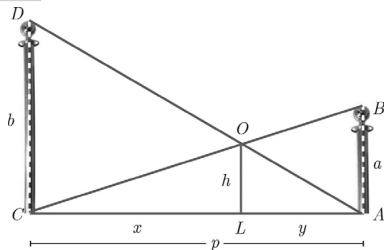

$CL = x$ and $LA = y$. Then, $x + y = p$

In $\triangle ABC$ and $\triangle LOC$, we have

$$\angle CAB = \angle CLO \text{ (each equal to } 90^\circ)$$

$$\angle C = \angle C \text{ (C - Common)}$$

$\triangle CAB \sim \triangle CLO$ (by AA similarity)

$$\frac{CA}{CL} = \frac{AB}{LO} \text{ gives } \frac{p}{x} = \frac{a}{h}$$

$$\text{So, } x = \frac{ph}{a} \text{ ----- (1)}$$

In $\triangle ALO$ and $\triangle ACD$, we have

$$\angle ALO = \angle ACD \text{ (each equal to } 90^\circ)$$

$$\angle A = \angle A \text{ (A - Common)}$$

$\triangle ALO \sim \triangle ACD$ (By AA Similarity)

$$\frac{AL}{AC} = \frac{OL}{DC} \text{ gives } \frac{y}{p} = \frac{h}{b}$$

$$\text{We get } y = \frac{ph}{b} \text{ ----- (2)}$$

$$(1) + (2) \text{ gives, } x + y = \frac{ph}{a} + \frac{ph}{b}$$

$$p = ph \left(\frac{1}{a} + \frac{1}{b} \right) \text{ (Since } x+y = p)$$

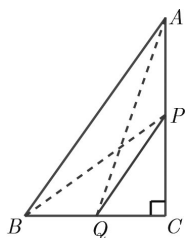
Solution:

Since ΔAQC is a right triangle at C,

$$AQ^2 = AC^2 + QC^2 \quad \text{----- (1)}$$

Also ΔBPC is a right triangle,

$$BP^2 = BC^2 + CP^2 \quad \text{----- (2)}$$

From (1) and (2)

$$AQ^2 + BP^2 = AC^2 + QC^2 + BC^2 + CP^2$$

$$4(AQ^2 + BP^2)$$

$$= 4AC^2 + 4QC^2 + 4BC^2 + 4CP^2$$

$$= 4AC^2 + (2QC)^2 + 4BC^2 + (2CP)^2$$

$$= 4AC^2 + BC^2 + 4BC^2 + AC^2$$

$$\text{(Since P and Q are mid points)}$$

$$= 5(AC^2 + BC^2)$$

$$4(AQ^2 + BP^2) = 5AB^2 \quad \text{(By Pythagoras Theorem)}$$

4. An Aeroplane after take off from an airport and flies due north at a speed of 1000 km/hr. At the same time, another aeroplane take off from the same airport and flies due west at a speed of 1200 km/hr. How far apart will be the two planes after $1\frac{1}{2}$ hours? **MAY-22**

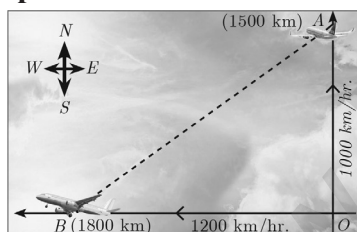
**Solution:**

Let the first aeroplane starts from O and goes upto A towards north.

(Distance = Speed x Time)

$$\text{Where, } OA = \left(1000 \times \frac{3}{2}\right) \text{ km} = 1500 \text{ km}$$

Let the Second aeroplane starts from O at the same time and goes upto B towards west.

$$\text{Where, } OB = \left(1200 \times \frac{3}{2}\right) \text{ km} = 1800 \text{ km}$$

The required distance to be found is BA.

In right angled triangle AOB,

$$AB^2 = OA^2 + OB^2$$

$$AB^2 = (1500)^2 + (1800)^2$$

$$= 100^2 (15^2 + 18^2)$$

$$= 100^2 \times 549 = 100^2 \times 9 \times 61$$

$$AB = 100 \times 3 \times \sqrt{61}$$

$$= 300\sqrt{61} \text{ km}$$

5. 5 m long ladder is placed leaning towards a vertical wall such that it reaches the wall at a point 4m high. If the foot of the ladder is moved 1.6 m towards the wall, then find the distance by which the top of the ladder would slide upwards on the wall.

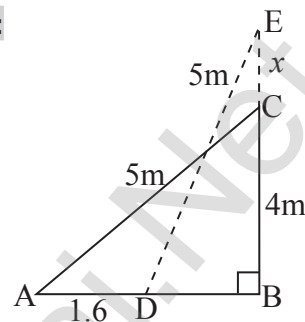
Solution:

Length of the Ladder, AC = 5 cm,

Height of Wall, BC = 4cm, AD = 1.6 cm,

Let EC = X

From ΔABC , By Pythagorous theorem

$$AB = \sqrt{AC^2 - BC^2}$$

$$= \sqrt{25 - 16} = \sqrt{9}$$

$$AB = 3 \text{ m}$$

From the figure we have,

$$AB = AD + BD$$

$$3 = 1.6 + BD$$

$$\Rightarrow BD = 1.4 \text{ m}$$

In ΔDBE , By Pythagorous theorem

$$(BE)^2 = (DE)^2 - (BD)^2$$

$$(4 + x)^2 = 5^2 - (1.4)^2$$

$$(4 + x)^2 = 23.04$$

$$4 + x = \sqrt{23.04}$$

$$= 4.8$$

$$\therefore x = 0.8$$

The distance by which top of the slide moves upwards is 0.8m.

6. The perpendicular PS on the base QR of a ΔPQR intersects QR at S, such that QS = 3 SR. Prove that $2PQ^2 = 2PR^2 + QR^2$

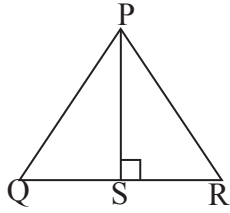
Solution:In ΔPQR , $QR \perp PS$ Given $QS = 3SR$ **To prove:** $2PQ^2 = 2PR^2 + QR^2$

$$\therefore QR = QS + SR$$

$$= 3SR + SR$$

$$QR = 4SR$$

$$SR = \frac{1}{4} QR$$

In ΔPQS , $PQ^2 = PS^2 + QS^2$ ----- (1)In ΔPRS , $PR^2 = PS^2 + SR^2$ ----- (2)

$$(1) - (2) \Rightarrow PQ^2 - PR^2 = QS^2 - SR^2$$

$$= (3SR)^2 - SR^2$$

$$= 9SR^2 - SR^2$$

$$= 8SR^2$$

$$= 8\left(\frac{1}{4}QR\right)^2$$

$$= 8\left(\frac{1}{16}QR^2\right)$$

$$PQ^2 - PR^2 = \frac{QR^2}{2}$$

$$2PQ^2 - 2PR^2 = QR^2$$

$$2PQ^2 = 2PR^2 + QR^2$$

Hence Proved.

7. In the adjacent figure, ABC is a right angled triangle with right angle at B and points D, E trisect BC. Prove that $8AE^2 = 3AC^2 + 5AD^2$

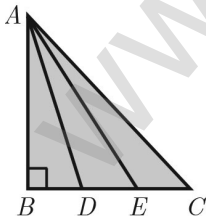
Solution:

D, E trisect BC.

Let $BD = DE = EC = k$, $BC = 3k$, $BE = 2k$ In ΔABC , by Pythagoras

$$\Rightarrow AC^2 = AB^2 + BC^2$$

$$\Rightarrow AC^2 = AB^2 + (3k)^2$$

$$AB^2 = AC^2 - 9k^2$$

..... (1)

In ΔABE , by Pythagoras

$$\Rightarrow AE^2 = AB^2 + BE^2$$

$$\Rightarrow AE^2 = AB^2 + (2k)^2$$

$$AB^2 = AE^2 - 4k^2$$

..... (2)

In ΔABD , by Pythagoras

$$AD^2 = AB^2 + BD^2$$

$$\Rightarrow AB^2 = AD^2 - k^2$$

..... (3)

(1), (2) \Rightarrow

$$AC^2 - AE^2 = 5k^2 \quad (\because (1)=(2))$$

..... (4)

$$(2), (3) \Rightarrow AE^2 - AD^2 = 3k^2$$

..... (5)

$$(4) \times 3 - (5) \times 5$$

$$\Rightarrow 3AC^2 - 3AE^2 = 15k^2$$

$$5AE^2 - 5AD^2 = 15k^2$$

$$3AC^2 - 8AE^2 + 5AD^2 = 0$$

$$\therefore 8AE^2 = 3AC^2 + 5AD^2$$

Hence the proof.

8. PQ is a chord of length 8 cm to a circle of radius 5 cm. The tangents at P and Q intersect at a point T. Find the length of the tangent TP.

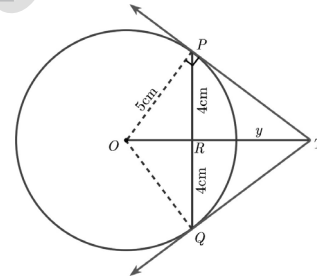
Solution:

$$\text{Let } TR = y$$

Since, OT is perpendicular bisector of PQ.

$$PR = QR = 4 \text{ cm}$$

$$\text{In } \Delta ORP \quad OP^2 = OR^2 + PR^2$$

$$OR^2 = 5^2 + 4^2$$

$$= 25 - 16 = 9$$

$$\Rightarrow OR = 3 \text{ cm}$$

$$OT = OR + RT = 3 + y$$

..... (1)

$$\text{In } \Delta PRT, TP^2 = TR^2 + PR^2$$

..... (2)

and ΔOPT we have,

$$OT^2 = TP^2 + OP^2$$

$$OT^2 = (TR^2 + PR^2) + OP^2$$

$$\text{(Substitute for } TP^2 \text{ from (2))}$$

$$(3 + y)^2 = y^2 + 4^2 + 5^2$$

$$\text{(Substitute for } OT \text{ from (1))}$$

$$9 + 6y + y^2 = y^2 + 16 + 25$$

$$6y = 41 - 9$$

$$\text{we get } y = \frac{16}{3}$$

$$\text{From (2) } TP^2 = TR^2 + PR^2$$

$$\begin{aligned} TP^2 &= \left(\frac{16}{3}\right)^2 + 4^2 \\ &= \frac{256}{9} + 16 = \frac{400}{9} \end{aligned}$$

$$\text{So } TP = \frac{20}{3} \text{ cm}$$

9. Suppose AB, AC and BC have lengths 13, 14 and 15 respectively. If $\frac{AF}{FB} = \frac{2}{5}$ and $\frac{CE}{EA} = \frac{5}{8}$. Find BD and DC.

Solution:

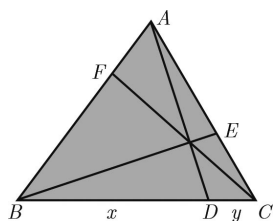

Given AB = 13, AC = 14 and BC = 15.

Let BD = x and DC = y

Using Ceva's theorem, we have

$$\frac{BD}{DC} \times \frac{CE}{EA} \times \frac{AF}{FB} = 1 \quad \text{----(1)}$$

Substitute the values of $\frac{AF}{FB}$ and $\frac{CE}{EA}$ in (1),

$$\text{we have } \frac{BD}{DC} \times \frac{5}{8} \times \frac{2}{5} = 1$$

$$\frac{x}{y} \times \frac{10}{40} = 1 \Rightarrow \frac{x}{y} \times \frac{1}{4} = 1.$$

$$\text{Hence, } x = 4y \quad \text{----(2)}$$

$$BC = BD + DC = 15. \text{ So, } x + y = 15 \quad \text{----(3)}$$

From (2), using $x = 4y$ in (3) we get

$$4y + y = 15 \Rightarrow 5y = 15 \text{ then } y = 3$$

Substitute $y = 3$ in (3) we get, $x = 12$.

Hence BD = 12, DC = 3.

10. In a garden containing several trees, three particular trees P, Q, R are located in the following way, BP = 2 m, CQ = 3 m, RA = 10 m, PC = 6 m, QA = 5 m, RB = 2 m, where A, B, C are points such that P lies on BC, Q lies on AC and R lies on AB. Check whether the trees P, Q, R lie on a same straight line.

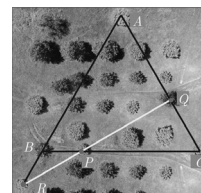

Solution:

By Menelaus's theorem, the trees P, Q, R will be collinear (lie on same straight line)

$$\text{if } \frac{BP}{PC} \times \frac{CQ}{QA} \times \frac{AR}{RB} = 1 \quad \text{....(1)}$$

Given BP = 2m, CQ = 3 m, RA = 10m,

PC = 6m, QA = 5m, RB = 2m.

Substituting these values in (1), we get

$$\frac{BP}{PC} \times \frac{CQ}{QA} \times \frac{AR}{RB} = \frac{2}{6} \times \frac{3}{5} \times \frac{10}{2} = \frac{60}{60} = 1$$

Hence the trees, P, Q, R lie on a same straight line.

11. A circle is inscribed in $\triangle ABC$ having sides 8 cm, 10 cm and 12 cm as shown in figure, Find AD, BE and CF.

Solution:

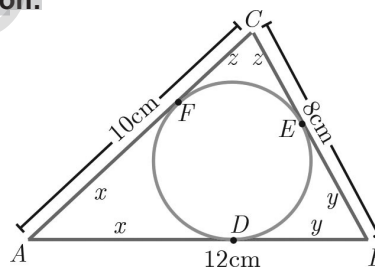

By result for tangents from external point

$$AD = AF = x, DB = BE = y, EC = CF = z$$

From the figure

$$x + y = AB = 10 \quad \text{..... (1)}$$

$$y + z = BC = 8 \quad \text{..... (2)}$$

$$z + x = CA = 12 \quad \text{..... (3)}$$

$$(1) + (2) + (3)$$

$$AB + BC + AC = 30$$

$$\Rightarrow x + y + y + z + z + x = 30$$

$$\Rightarrow 2(x + y + z) = 30$$

$$x + y + z = 15 \quad \text{.... (4)}$$

$$AB = AD + DB = 10$$

$$\Rightarrow x + y + z = 15$$

$$10 + z = 15$$

$$z = 5$$

$$\Rightarrow x + y + z = 15$$

$$x + 8 = 15$$

$$x = 7$$

$$\Rightarrow x + y + z = 15$$

$$10 + y = 15$$

$$y = 5$$

Hence AD = 7 cm, BE = 5 cm, CF = 3 cm

12. Show that the angle bisectors of a triangle are concurrent.

Solution:

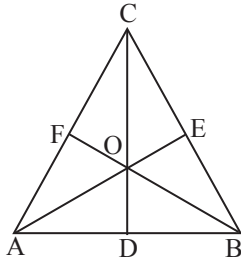

Let O be any point inside a triangle ABC.

The bisector of CD, AE and BF meet the sides AB, BC, CA at point D, E and F respectively.

In $\triangle AOB$, OD is the bisector of $\angle AOB$

$$\therefore \frac{OA}{OB} = \frac{AD}{DB}$$

(by angle bisector theorem) (1)

In $\triangle BOC$, OE is the bisector of $\angle BOC$

$$\therefore \frac{OB}{OC} = \frac{BE}{EC} \quad \text{..... (2)}$$

In $\triangle COA$, OF is the bisector of $\angle COA$

$$\therefore \frac{OC}{OA} = \frac{CF}{FA} \quad \text{..... (3)}$$

(1)×(2)×(3) \Rightarrow

$$\frac{OA}{OB} \times \frac{OB}{OC} \times \frac{OC}{OA} = \frac{AD}{DB} \times \frac{BE}{EC} \times \frac{CF}{FA}$$

$$\Rightarrow \frac{AD}{DB} \times \frac{BE}{EC} \times \frac{CF}{FA} = 1$$

But if AE, BF and CD are the bisectors of $\angle A$, $\angle B$ and $\angle C$, then

$$\frac{AB}{AC} = \frac{BE}{EC}, \frac{BC}{AB} = \frac{CF}{FA}, \frac{CA}{CB} = \frac{AD}{DB}$$

Hence from the above 3 equations, we get

$$\frac{BE}{EC} \times \frac{CF}{FA} \times \frac{AD}{DB}$$

$$= \frac{AB}{AC} \times \frac{BC}{AB} \times \frac{CA}{CB} = 1 \quad \text{(from (4))}$$

Hence, O is point of concurrence of the angle bisectors.

***.

5

Coordinate Geometry

2 Marks

STAGE 2

1. Find the slope of a line joining the given points (i) $(-6, 1)$ and $(-3, 2)$ (ii) $(14, 10)$ and $(14, -6)$

SEP-20

Solution:

i) $(-6, 1)$ and $(-3, 2)$

$$\begin{aligned} \text{Slope, } m &= \frac{y_2 - y_1}{x_2 - x_1} = \frac{2 - 1}{-3 - (-6)} \\ &= \frac{2 - 1}{-3 + 6} \end{aligned}$$

$$\therefore \text{Slope, } m = \frac{1}{3}$$

ii) $(14, 10)$ and $(14, -6)$

$$\text{Slope, } m = \frac{y_2 - y_1}{x_2 - x_1} = \frac{-6 - 10}{14 - 14} = \frac{-16}{0}$$

$$\therefore \text{Slope, } m = \frac{-16}{0}$$

The slope is undefined.

2. The line r passes through the points $(-2, 2)$ and $(5, 8)$ and the line s passes through the points $(-8, 7)$ and $(-2, 0)$. Is the line r perpendicular to s ?

Solution:

$$\text{The slope of line } r \text{ is } m_1 = \frac{8 - 2}{5 + 2} = \frac{6}{7}$$

$$\text{The slope of line } s \text{ is } m_2 = \frac{0 - 7}{-2 + 8} = \frac{-7}{6}$$

$$\text{The product of slopes} = \frac{6}{7} \times \frac{-7}{6} = -1$$

$$\text{That is, } m_1 m_2 = -1$$

Therefore, the line r is perpendicular to line s .

3. The line p passes through the points $(3, -2)$, $(12, 4)$ and the line q passes through the points $(6, -2)$ and $(12, 2)$. Is p parallel to q ?

MAY-22

Solution:

$$\text{The slope of line } p \text{ is } m_1 = \frac{4 + 2}{12 - 3} = \frac{6}{9} = \frac{2}{3}$$

$$\text{The slope of line } q \text{ is } m_2 = \frac{2 + 2}{12 - 6} = \frac{4}{6} = \frac{2}{3}$$

Thus, slope of line p = slope of line q .

Therefore, line p is parallel to the line q .

4. Show that the points $(-2, 5)$, $(6, -1)$ and $(2, 2)$ are collinear.

Solution:

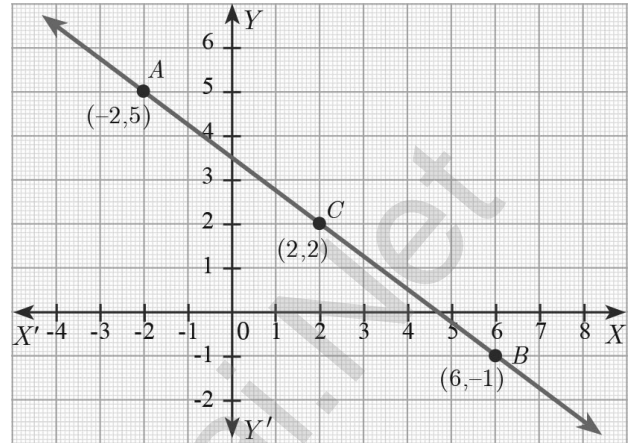

$$\text{Slope of } AB = \frac{-1 - 5}{6 + 2} = \frac{-6}{8} = \frac{-3}{4}$$

$$\text{Slope of } BC = \frac{2 + 1}{2 - 6} = \frac{3}{-4} = \frac{-3}{4}$$

$$\text{Slope of } AB = \text{Slope of } BC$$

Therefore, the points A, B, C all lie in a same straight line.

Hence A, B and C are collinear.

5. Find the slope of a line joining the points

(i) $(5, \sqrt{5})$ with the origin

(ii) $(\sin \theta, -\cos \theta)$ and $(-\sin \theta, \cos \theta)$

Solution:

i) Given points are $(5, \sqrt{5})$ and $(0, 0)$

$$\text{Slope} = m$$

$$= \frac{y_2 - y_1}{x_2 - x_1} = \frac{0 - \sqrt{5}}{0 - 5}$$

$$= \frac{\sqrt{5}}{5} = \frac{1}{\sqrt{5}}$$

ii) Given points are

$(\sin \theta, -\cos \theta)$ and $(-\sin \theta, \cos \theta)$

$$\text{Slope} = m$$

$$= \frac{y_2 - y_1}{x_2 - x_1}$$

$$= \frac{\cos \theta - (-\cos \theta)}{-\sin \theta - \sin \theta}$$

$$= \frac{2 \cos \theta}{-2 \sin \theta} = -\cot \theta$$

6. What is the slope of a line perpendicular to the line joining A(5, 1) and P where P is the mid-point of the segment joining (4, 2) and (-6, 4).

Solution:

P is the midpoint of the segment joining (4, 2) and (-6, 4)

$$P(x, y) = \left(\frac{x_1 + x_2}{2}, \frac{y_1 + y_2}{2} \right)$$

$$= \left(\frac{4 + (-6)}{2}, \frac{2 + 4}{2} \right)$$

A (5, 1) and P (-1, 3)

$$\text{Slope of AP} = \frac{y_2 - y_1}{x_2 - x_1}$$

$$= \frac{3 - 1}{-1 - 5} = \frac{2}{-6} = \frac{-1}{3}$$

$$\text{Slope of the line perpendicular to AP}$$

$$= \frac{-1}{\text{slope of AP}} = \frac{-1}{\frac{-1}{3}} = 3$$

7. Show that the given points are collinear: (-3, -4), (7, 2) and (12, 5)

Solution:

$$\text{Slope of AB} = \frac{2 - (-4)}{7 - (-3)} = \frac{6}{10} = \frac{3}{5} \quad \dots(1)$$

$$\text{Slope of BC} = \frac{5 - 2}{12 - 7} = \frac{3}{5} \quad \dots(2)$$

$$\text{Slope of AC} = \frac{5 - (-4)}{12 - (-3)} = \frac{9}{15} = \frac{3}{5} \quad \dots(3)$$

From (1), (2), (3) \Rightarrow the given points A, B, C are collinear.

8. If the three points (3, -1), (a, 3) and (1, -3) are collinear, find the value of a.

Solution:

Let the given points A (3, -1), B (a, 3) and C (1, -3) and given A, B and C are collinear.

\therefore Slope of AB = Slope of BC

$$\Rightarrow \frac{3 - (-1)}{a - 3} = \frac{-3 - 3}{1 - a}$$

$$\Rightarrow \frac{4}{a - 3} = \frac{-6}{1 - a}$$

$$\Rightarrow 4 - 4a = -6a + 18$$

$$\Rightarrow 2a = 14$$

$$\Rightarrow a = 7$$

9. The line through the points (-2, a) and (9, 3) has slope -12. Find the value of a.

Solution:

The slope of the points (-2, a) and (9, 3)

$$= -\frac{1}{2}$$

$$\text{Slope} = \frac{y_2 - y_1}{x_2 - x_1}$$

$$= \frac{3 - a}{9 + 2} = \frac{3 - a}{11}$$

$$\therefore \frac{3 - a}{11} = -\frac{1}{2}$$

$$6 - 2a = -11$$

$$2a = 17$$

$$a = \frac{17}{2}$$

10. The line through the points (-2, 6) and (4, 8) is perpendicular to the line through the points (8, 12) and (x, 24). Find the value of x.

Solution:

Slope of line joining (-2, 6), (4, 8)

$$m_1 = \frac{8 - 6}{4 + 2} = \frac{2}{6} = \frac{1}{3}$$

Slope of line joining (8, 12) (x, 24)

$$m_2 = \frac{24 - 12}{x - 8} = \frac{12}{x - 8}$$

Since two lines are perpendicular

$$m_1 \times m_2 = -1$$

$$\Rightarrow \frac{1}{3} \times \frac{12}{x - 8} = -1$$

$$\Rightarrow \frac{4}{x - 8} = -1$$

$$\Rightarrow x - 8 = -4$$

$$\Rightarrow x = 4$$

11. Find the equation of a straight line whose

(i) Slope is 5 and y intercept is -9

(ii) Inclination is 45° and y intercept is 11

Solution:

- i) Given Slope, $m = 5$, y intercept, $c = -9$

Therefore, equation of a straight line is,

$$y = mx + c$$

$$y = 5x - 9$$

$$0 = 5x - y - 9$$

\therefore Required equation is $5x - y - 9 = 0$

ii) Given, $\theta=45^\circ$, y intercept, $c = 11$

$$\text{Slope, } m = \tan \theta$$

$$m = \tan 45^\circ$$

$$\text{Slope, } m = 1$$

$$\text{y intercept, } C = 11$$

Therefore, equation of a straight line is,

$$y = mx + C$$

$$y = 1x + 11$$

$$0 = x - y + 11$$

\therefore Required equation is $x - y + 11 = 0$

12. Calculate the slope and y intercept of the straight line $8x - 7y + 6 = 0$

SEP-21

Solution:

$$8x - 7y + 6 = 0$$

$$8x + 6 = 7y$$

$$(\div 7) \quad \frac{8}{7}x + \frac{6}{7} = \frac{7}{7}y$$

$$\frac{8}{7}x + \frac{6}{7} = y$$

$$\text{Comparing } y = mx + C$$

$$\text{Slope, } m = \frac{8}{7}$$

$$\text{y intercept, } C = \frac{6}{7}$$

13. Find the equation of a line passing through the point $(3, -4)$ and having slope $\frac{-5}{7}$

Solution:

$$(x_1, y_1) = (3, -4)$$

$$\text{Slope, } m = -\frac{5}{7}$$

Equation of the straight line

$$y - y_1 = m(x - x_1)$$

$$y - (-4) = -\frac{5}{7}(x - 3)$$

$$7(y + 4) = -5(x - 3)$$

$$7y + 28 = -5x + 15$$

$$5x + 7y + 28 - 15 = 0$$

$$5x + 7y + 13 = 0$$

14. Find the equation of a line passing through the point A $(1, 4)$ and perpendicular to the line joining points $(2, 5)$ and $(4, 7)$.

Solution:

Let the given points be A $(1, 4)$, B $(2, 5)$ and C $(4, 7)$

$$\text{Slope of line BC} = \frac{7-5}{4-2} = \frac{2}{2} = 1$$

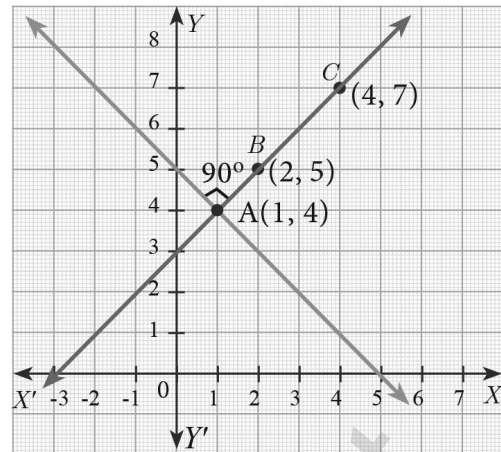

Let m be the slope of the required line.

Since the required line is perpendicular to BC.

$$m \times 1 = -1$$

$$m = -1$$

The required line also pass through the point

A $(1, 4)$

The equation of the required straight line is

$$y - y_1 = m(x - x_1)$$

$$y - 4 = -1(x - 1)$$

$$y - 4 = -x + 1$$

We get, $x + y - 5 = 0$

15. Find the equation of a line which passes through $(5, 7)$ and makes intercepts on the axes equal in magnitude but opposite in sign.

Solution:

Let the x intercept be ' a ' and y intercept be ' $-a$ '

The equation of the line in intercept form is

$$\frac{x}{a} + \frac{y}{b} = 1$$

$$\frac{x}{a} + \frac{y}{b} = 1 \quad (\text{Here } b = -a)$$

$$\therefore \quad x - y = a \quad \dots (1)$$

Since (1) passes through $(5, 7)$

Therefore, $5 - 7 = a \Rightarrow a = -2$

Thus the required equation of the straight line is $x - y = -2$; or $x - y + 2 = 0$

16. Find the intercepts made by the line $4x - 9y + 36 = 0$ on the coordinate axes.

Solution:

Equation of the given line is $4x - 9y + 36 = 0$

We write it as $4x - 9y = -36$ (bringing it to the normal form)

$$\text{Dividing by } -36 \text{ we get, } \frac{x}{-9} + \frac{y}{4} = 1 \quad \dots (1)$$

Comparing (1) with intercept form,
we get x intercept $a = -9$;
my intercept to $b = 4$

17. Find the equation of a straight line passing through the mid-point of a line segment joining the points (1, -5), (4, 2) and parallel to (i) X axis (ii) Y axis

Solution:

Let M be the midpoint of a line segment joining the points (1, -5) and (4, 2).

$$\therefore M(x, y) = \left(\frac{1+4}{2}, \frac{-5+2}{2} \right) = \left(\frac{5}{2}, \frac{-3}{2} \right)$$

- i) Equation parallel to Y - axis is $y = b$.

It passes through the points $\left(\frac{5}{2}, \frac{-3}{2} \right)$

$$\therefore y = -\frac{3}{2}$$

$$\Rightarrow y + \frac{3}{2} = 0$$

$$\Rightarrow 2y + 3 = 0$$

- ii) Equation parallel to X - axis is $x = a$.

It passes through the points $\left(\frac{5}{2}, \frac{-3}{2} \right)$

$$\therefore x = \frac{5}{2}$$

$$\Rightarrow x - \frac{5}{2} = 0$$

$$\Rightarrow 2x - 5 = 0$$

18. The equation of a straight line is $2(x-y)+5=0$. Find its slope, inclination and intercept on the Y axis.

Solution:

$$\text{Given equation } 2(x-y) + 5 = 0$$

$$\Rightarrow 2x - 2y + 5 = 0$$

$$\Rightarrow 2y = 2x + 5$$

$$\Rightarrow y = x + \frac{5}{2} \quad (\because y = mx + c)$$

$$\therefore \text{Slope, } m = 1, \Rightarrow \tan \theta = 1, \theta = 45^\circ$$

$$Y - \text{intercept is } \frac{5}{2}.$$

19. Find the equation of a line whose inclination is 30° and making an intercept -3 on the Y axis.

Solution:

$$\text{Given } \theta = 30^\circ \text{ and } C = -3$$

$$m = \tan 30^\circ = \frac{1}{\sqrt{3}}$$

Slope intercept form :

$$y = mx + C$$

$$y = \frac{1}{\sqrt{3}}x + (-3)$$

$$\sqrt{3} y = x - 3\sqrt{3}$$

$$x - \sqrt{3} y - 3\sqrt{3} = 0$$

20. Find the slope and y intercept of $\sqrt{3}x + (1-\sqrt{3})y = 3$.

Solution:

Given equation of the straight line is

$$\sqrt{3}x + (1-\sqrt{3})y = 3$$

$$(1-\sqrt{3})y = -\sqrt{3}x + 3$$

$$y = \left(\frac{-\sqrt{3}}{1-\sqrt{3}} \right)x + \left(\frac{3}{1-\sqrt{3}} \right) \quad (\because y = mx + c)$$

$$\text{Slope, } m = -\frac{\sqrt{3}}{1-\sqrt{3}} = \frac{-\sqrt{3}}{1-\sqrt{3}} \times \frac{1+\sqrt{3}}{1+\sqrt{3}}$$

$$= \frac{-(\sqrt{3}+3)}{-2} = \frac{3+\sqrt{3}}{2}$$

$$\text{Intercept, } C = \frac{3}{1-\sqrt{3}}$$

$$= \frac{3}{1-\sqrt{3}} \times \frac{1+\sqrt{3}}{1+\sqrt{3}}$$

$$= \frac{3+\sqrt{3}}{-2}$$

21. Find the value of 'a', if the line through (-2, 3) and (8, 5) is perpendicular to $y = ax + 2$

Solution:

Let m_1 be the slope of line joining (-2, 3) and (8, 5) and

Let m_2 be slope of $y = ax + 2$

$$m_1 = \frac{5-3}{8-(-2)} = \frac{2}{10} = \frac{1}{5}$$

$$m_2 = a$$

Two lines are perpendicular, its slope are

$$m_1 m_2 = -1$$

$$\Rightarrow \frac{1}{5} \times (a) = -1 \Rightarrow a = -5$$

22. Find the equation of a line through the given pair of points

$$(i) \left(2, \frac{2}{3} \right) \left(\frac{-1}{2}, -2 \right) \quad (ii) (2, 3) \text{ and } (-7, -1)$$

Solution:

Equation of the straight line 'Two points Form' is

$$\frac{y - y_1}{y_2 - y_1} = \frac{x - x_1}{x_2 - x_1}$$

i) $\left(2, \frac{2}{3}\right)$ and $\left(\frac{-1}{2}, -2\right)$

The required equation

$$\frac{y - \frac{2}{3}}{-2 - \frac{2}{3}} = \frac{x - 2}{\frac{-1}{2} - 2}$$

$$\Rightarrow \frac{3y - 2}{-8} = \frac{x - 2}{\frac{-5}{2}}$$

$$\Rightarrow \frac{3y - 2}{-8} = \frac{2x - 4}{-5}$$

$$\Rightarrow -15y + 10 = -16x + 32$$

$$\Rightarrow 16x - 15y - 22 = 0$$

ii) $(2, 3)$ and $(-7, -1)$

The required equation

$$\Rightarrow \frac{y - 3}{-1 - 3} = \frac{x - 2}{-7 - 2}$$

$$\Rightarrow \frac{y - 3}{-4} = \frac{x - 2}{-9}$$

$$\Rightarrow -9y + 27 = -4x + 8$$

$$\Rightarrow 4x - 9y + 19 = 0$$

23. A cat is located at the point $(-6, -4)$ in xy plane. A bottle of milk is kept at $(5, 11)$. The cat wish to consume the milk travelling through shortest possible distance. Find the equation of the path it needs to take its milk.

Solution:

The required equation of the line joining the points $(-6, -4)$ and $(5, 11)$

Two points form:

$$\frac{y - y_1}{y_2 - y_1} = \frac{x - x_1}{x_2 - x_1}$$

$$\Rightarrow \frac{y - (-4)}{11 - (-4)} = \frac{x - (-6)}{5 - (-6)}$$

$$\Rightarrow \frac{y + 4}{15} = \frac{x + 6}{11}$$

$$\Rightarrow 11y + 44 = 15x + 90$$

$$\Rightarrow 15x - 11y + 90 - 44 = 0$$

$$\Rightarrow 15x - 11y + 46 = 0$$

24. Find the equation of a straight line which has slope $-5/4$ and passing through the point $(-1, 2)$. MAY-22

Solution:

Given a point $(-1, 2)$ and slope, $-\frac{5}{4}$

The required equation, $y - y_1 = m(x - x_1)$

$$\Rightarrow y - 2 = \frac{-5}{4} (x - (-1))$$

$$\Rightarrow 4y - 8 = -5x - 5$$

$$\Rightarrow 5x + 4y - 3 = 0$$

25. Find the equation of a line whose intercepts on the x and y axes are given below.

(i) 4, -6 (ii) $-5, \frac{3}{4}$

Solution:

- i) x intercept, $a = 4$, y intercept, $b = -6$

Equation of the straight line

$$\frac{x}{a} + \frac{y}{b} = 1$$

$$\frac{x}{4} + \frac{y}{-6} = 1$$

$$\frac{x}{4} - \frac{y}{6} = 1$$

$$\frac{6x - 4y}{24} = 1$$

$$\frac{2(3x - 2y)}{24} = 1$$

$$\frac{3x - 2y}{12} = 1$$

$$3x - 2y = 12$$

$$3x - 2y - 12 = 0$$

$$x \text{ intercept, } a = -5, y \text{ intercept, } b = \frac{3}{4}$$

- ii) Equation of the straight line

$$\frac{x}{a} + \frac{y}{b} = 1$$

$$\frac{x}{-5} + \frac{y}{\frac{3}{4}} = 1$$

$$\frac{x}{-5} + \frac{4y}{3} = 1$$

$$\frac{3x - 20y}{-15} = 1$$

$$3x - 20y = -15$$

$$3x - 20y + 15 = 0$$

26. Find the intercepts made by the following lines on the coordinate axes. **SEP-21**

(i) $3x - 2y - 6 = 0$ (ii) $4x + 3y + 12 = 0$

Solution:

Intercepts form : $\frac{x}{a} + \frac{y}{b} = 1$

\therefore a - x intercepts, b - y intercepts

i) $3x - 2y - 6 = 0$

$$\Rightarrow 3x - 2y = 6 \Rightarrow \frac{3x}{6} - \frac{2y}{6} = 1$$

$$\Rightarrow \frac{x}{2} + \frac{y}{-3} = 1$$

$$\Rightarrow \therefore a = 2, b = -3$$

ii) $4x + 3y + 12 = 0$

$$4x + 3y = -12 (\div -12)$$

$$\Rightarrow \frac{4x}{-12} + \frac{3y}{-12} = 1$$

$$\Rightarrow \frac{x}{-3} + \frac{y}{-4} = 1$$

$$\Rightarrow \therefore a = -3, b = -4$$

27. Find the slope of the straight line $6x + 8y + 7 = 0$.

Solution:

Given $6x + 8y + 7 = 0$

$$\text{Slope } m = \frac{-\text{coefficient of } x}{\text{coefficient of } y} = -\frac{6}{8} = -\frac{3}{4}$$

Therefore, the slope of the straight line is $-\frac{3}{4}$.

28. Find the slope of the line which is

(i) parallel to $3x - 7y = 11$

(ii) perpendicular to $2x - 3y + 8 = 0$

Solution:

i) Given straight line is $3x - 7y = 11$

gives, $3x - 7y - 11 = 0$

$$\text{Slope, } m = \frac{-3}{-7} = \frac{3}{7}$$

Since parallel line have same slopes, slope of any line parallel to

$$3x - 7y = 11 \text{ is } \frac{3}{7}$$

ii) Given straight line is $2x - 3y + 8 = 0$

$$\text{Slope, } m = \frac{-2}{-3} = \frac{2}{3}$$

Some product of slope is -1 for perpendicular lines, slope of any line perpendicular to

$$2x - 3y + 8 = 0 \text{ is } \frac{-1}{\frac{2}{3}} = \frac{-3}{2}$$

29. Show that the straight lines $2x + 3y - 8 = 0$ and $4x + 6y + 18 = 0$ are parallel.

Solution:

Slope of the straight line $2x + 3y - 8 = 0$

$$m_1 = \frac{-\text{coefficient of } x}{\text{coefficient of } y} = -\frac{2}{3}$$

Slope of the straight line $4x + 6y + 18 = 0$

$$m_2 = \frac{-\text{coefficient of } x}{\text{coefficient of } y} = -\frac{2}{3}$$

Here $m_1 = m_2$

That is, slopes are equal.

Hence, the two straight lines are parallel.

30. Show that the straight lines $x - 2y + 3 = 0$ and $6x + 3y + 8 = 0$ are perpendicular.

Solution:

Slope of the straight line $x - 2y + 3 = 0$

$$m_1 = -\left(\frac{a}{b}\right) = -\left(\frac{1}{-2}\right) = \frac{1}{2}$$

Slope of the straight line $6x + 3y + 8 = 0$

$$m_2 = -\left(\frac{a}{b}\right) = -\left(\frac{6}{3}\right) = -2$$

$$m_1 \times m_2 = \frac{1}{2} \times (-2) = -1$$

Product of the slopes = -1

Hence, the two straight lines are perpendicular.

31. Find the slope of the following straight

lines (i) $5y - 3 = 0$ (ii) $7x - \frac{3}{17} = 0$

Solution:

i) $5y - 3 = 0$

$$\therefore \text{Slope, } m = \frac{-\text{coefficient of } x}{\text{coefficient of } y} = \frac{0}{5} = 0$$

ii) $7x - \frac{3}{17} = 0$

$$\Rightarrow 7x = \frac{3}{17}$$

$$\Rightarrow 0y + 7x + \frac{3}{17} = 0$$

$$\therefore \text{Slope, } m = \frac{-\text{coefficient of } x}{\text{coefficient of } y}$$

$$m = \frac{-7}{0}$$

$\therefore m = \infty$ (undefined)

32. Find the slope of the line which is

(i) parallel to $y = 0.7x - 11$

(ii) perpendicular to the line $x = -11$

Solution:

- i) $y = 0.7x - 11$
This line parallel to $y = 0.7x - k$
 \therefore The slope of the required line is 0.7
- ii) $x = -11$
 $\Rightarrow x + 0y + 11 = 0$
(1) line perpendicular to $0x - y + k = 0$
 $\Rightarrow y = 0x + k$
 \therefore The Slope of the required line is 0.

33. If the straight lines $12y = -(p + 3)x + 12$, $12x - 7y = 16$ are perpendicular then find 'p'.

Solution:

Given equation

$$12y = -(p + 3)x + 12$$

$$(p + 3)x + 12y + 12 = 0$$

$$\text{Slope, } m = \frac{-\text{coefficient of } x}{\text{coefficient of } y} = -\frac{(p + 3)}{12}$$

Slope of the line is $12x - 7y = 16$

$$m = -\frac{12}{-7} = \frac{12}{7}$$

Two Straight lines are perpendicular to each other

$$m_1 \times m_2 = -1$$

$$-\frac{(p + 3)}{12} \times \frac{12}{7} = -1$$

$$p + 3 = 7$$

$$\Rightarrow p = 7 - 3 \Rightarrow p = 4$$

34. Find the equation of a straight line passing through the point $P(-5, 2)$ and parallel to the line joining the points $Q(3, -2)$ and $R(-5, 4)$.

Solution:

Slope QR parallel to the line joining the points

$$= \frac{y_2 - y_1}{x_2 - x_1} = \frac{4 + 2}{-5 - 3} = \frac{6}{-8} = -\frac{3}{4}$$

$$\therefore m = -\frac{3}{4}$$

This is passing through the point $(-5, 2)$

$$\therefore y - y_1 = m(x - x_1)$$

$$y - 2 = -\frac{3}{4}(x + 5)$$

$$4y - 8 = -3x - 15$$

$$4y - 8 + 3x + 15 = 0$$

\therefore The required equation $3x + 4y + 7 = 0$

5 Marks**STAGE 2**

1. If the points $P(-1, -4)$, $Q(b, c)$ and $R(5, -1)$ are collinear and if $2b + c = 4$, then find the values of b and c . SEP-21

Solution:

Since the three points $P(-1, -4)$, $Q(b, c)$ and $R(5, -1)$ are collinear,

$$\text{Area of Triangle PQR} = 0$$

$$\frac{1}{2} \begin{vmatrix} -1 & -4 \\ b & c \\ 5 & -1 \end{vmatrix} = 0$$

$$\frac{1}{2} \{(-c - b - 20) - (-4b + 5c + 1)\} = 0$$

$$-c - b - 20 + 4b - 5c - 1 = 0$$

$$3b - 6c = 21 \quad (\div 3)$$

$$b - 2c = 7 \quad \dots (1)$$

Also, $2b + c = 4 \quad \dots (2)$

(From given information)

Solving (1) and (2) we get $b = 3$, $c = -2$

2. If the points $A(-3, 9)$, $B(a, b)$ and $C(4, -5)$ are collinear and if $a + b = 1$, then find a and b .

Solution:

Given $A(-3, 9)$, $B(a, b)$, $C(4, -5)$ are collinear and $a + b = 1$ (1)

Area of the triangle formed by 3 points = 0

$$\frac{1}{2} \begin{vmatrix} -3 & 9 \\ a & b \\ 4 & -5 \end{vmatrix} = 0$$

$$\Rightarrow (-3b - 5a + 36) - (9a + 4b + 15) = 0$$

$$\Rightarrow -5a - 3b + 36 - 9a - 4b - 15 = 0$$

$$\Rightarrow -14a - 7b + 21 = 0$$

$$\Rightarrow -14a - 7b = -21$$

$$\Rightarrow 14a + 7b = 21 \quad (\div 7)$$

$$\Rightarrow 2a + b = 3 \quad \dots (2)$$

Given $a + b = 1$ (1)

$$(1) - (2) \Rightarrow a = 2 \quad b = -1$$

3. Let $P(11, 7)$, $Q(13.5, 4)$ and $R(9.5, 4)$ be the midpoints of the sides AB , BC and AC respectively of ΔABC . Find the coordinates of the vertices A , B and C . Hence find the area of ΔABC and compare this with area of ΔPQR .

Solution:

P = Mid point of AB

$$\Rightarrow \left(\frac{x_1 + x_2}{2}, \frac{y_1 + y_2}{2} \right) = (11, 7)$$

$$\Rightarrow \frac{x_1 + x_2}{2} = 11 \Rightarrow x_1 + x_2 = 22 \quad \dots (1)$$

$$\Rightarrow \frac{y_1 + y_2}{2} = 7 \Rightarrow y_1 + y_2 = 14 \quad \dots (2)$$

Q = Mid point of BC

$$\Rightarrow \left(\frac{x_2 + x_3}{2}, \frac{y_2 + y_3}{2} \right) = (13.5, 4)$$

$$\Rightarrow \frac{x_2 + x_3}{2} = 13.5 \Rightarrow x_2 + x_3 = 27 \quad \dots (3)$$

$$\Rightarrow \frac{y_2 + y_3}{2} = 4 \Rightarrow y_2 + y_3 = 8 \quad \dots (4)$$

R = Mid point of AC

$$\Rightarrow \left(\frac{x_1 + x_3}{2}, \frac{y_1 + y_3}{2} \right) = (9.5, 4)$$

$$\Rightarrow \frac{x_1 + x_3}{2} = 9.5 \Rightarrow x_1 + x_3 = 19 \quad \dots (5)$$

$$\Rightarrow \frac{y_1 + y_3}{2} = 4 \Rightarrow y_1 + y_3 = 8 \quad \dots (6)$$

$$(1)+(3)+(5) \Rightarrow 2x_1 + x_2 + x_3 = 68$$

$$x_1 + x_2 + x_3 = 34 \quad \dots (7)$$

$$(2)+(4)+(6) \Rightarrow 2y_1 + y_2 + y_3 = 30$$

$$y_1 + y_2 + y_3 = 15 \quad \dots (8)$$

$$(7) - (1) \Rightarrow x_3 = 12$$

$$(7) - (3) \Rightarrow x_1 = 7$$

$$(7) - (5) \Rightarrow x_2 = 15$$

$$(8) - (2) \Rightarrow y_3 = 1$$

$$(8) - (4) \Rightarrow y_1 = 7$$

$$(8) - (6) \Rightarrow y_2 = 7$$

A(7, 7), B(15, 7) and C(12, 1)

$$\text{Area } \Delta ABC = \frac{1}{2} \begin{vmatrix} x_1 & y_1 \\ x_2 & y_2 \\ x_3 & y_3 \end{vmatrix} = \frac{1}{2} \begin{vmatrix} 7 & 7 \\ 15 & 7 \\ 12 & 1 \end{vmatrix}$$

$$= \frac{1}{2} [(49 + 15 + 84) - (105 + 84 + 7)]$$

$$= \frac{1}{2} [148 - 196] = \frac{1}{2} [-48] = 24 \text{ sq.units}$$

(∵ Area cannot be -ve)

$$\text{Area } \Delta PQR = \frac{1}{2} \begin{vmatrix} x_1 & y_1 \\ x_2 & y_2 \\ x_3 & y_3 \end{vmatrix} = \frac{1}{2} \begin{vmatrix} 11 & 7 \\ 13.5 & 4 \\ 9.5 & 4 \end{vmatrix}$$

$$= \frac{1}{2} [(44 + 54 + 66.5) - (94.5 + 38 + 44)]$$

$$= \frac{1}{2} [164.5 - 176.5]$$

$$= \frac{1}{2} [-12] = 6 \text{ sq.units}$$

(∵ Area cannot be -ve)

Now,

Area of $\Delta PQR = 6$ sq.unitsArea of $\Delta ABC = 24$ sq.units∴ Area of $\Delta ABC = 4 \times$ Area of ΔPQR

4. Prove analytically that the line segment joining the mid-points of two sides of a triangle is parallel to the third side and is equal to half of its length.

Solution:

Let P(a, b), Q(c, d) and R(e, f) be the vertices of a triangle.

Let S be the mid-point of PQ and T be mid-point of PR.

Therefore, $S = \left(\frac{a+c}{2}, \frac{b+d}{2} \right)$ and

$$T = \left(\frac{a+e}{2}, \frac{b+f}{2} \right)$$

$$\text{Now, Slope of ST} = \frac{\frac{b+f}{2} - \frac{b+d}{2}}{\frac{a+e}{2} - \frac{a+c}{2}} = \frac{f-d}{e-c}$$

$$\text{and Slope of QR} = \frac{f-d}{e-c}$$

Therefore, ST is parallel to QR. (Since, their slopes are equal)

Also,

$$ST = \sqrt{\left(\frac{a+e}{2} - \frac{a+c}{2} \right)^2 + \left(\frac{b+f}{2} - \frac{b+d}{2} \right)^2}$$

$$= \frac{1}{2} \sqrt{(e-c)^2 + (f-d)^2}$$

$$= \frac{1}{2} QR$$

Thus ST is parallel to QR and half of it.

5. Show that the given points form a right angled triangle and check whether they satisfies Pythagoras theorem.

i) A (1, -4), B (2, -3) and C (4, -7)

ii) L (0, 5), M (9, 12) and N (3, 14)

Solution:

i) **A(1, -4), B(2, -3) and C(4, -7)**

$$\text{Slope of AB} = \frac{-3 - (-4)}{2 - 1} = \frac{1}{1} = 1$$

$$\text{Slope of BC} = \frac{-7 - (-3)}{4 - 2} = \frac{-4}{2} = -2$$

$$\text{Slope of AC} = \frac{-7 + 4}{4 - (1)} = \frac{-3}{3} = -1$$

$$(\text{Slope of AB}) \times (\text{Slope of AC})$$

$$= 1 \times (-1) = -1$$

$\therefore \Delta ABC$ is a right angled triangle

($\because AB \perp AC$)

Using Pythagoras theorem,

$$AB^2 + AC^2 = BC^2$$

$$(\because d = \sqrt{(x_2 - x_1)^2 + (y_2 - y_1)^2})$$

$$AB^2 = (2 - 1)^2 + (-3 + 4)^2$$

$$= (1)^2 + (1)^2 = 2$$

$$AC^2 = (4 - 1)^2 + (-7 + 4)^2$$

$$= (3)^2 + (-3)^2 = 18$$

$$BC^2 = (4 - 2)^2 + (-7 + 3)^2$$

$$= (2)^2 + (-4)^2$$

$$= 4 + 16 = 20$$

$$AB^2 + AC^2 = 2 + 18 = 20 = BC^2$$

Hence it is satisfied.

ii) **L(0, 5), M(9, 12) and N(3, 11)**

$$\text{Slope of LM} = \frac{12 - 5}{9 - 0} = \frac{7}{9}$$

$$\text{Slope of MN} = \frac{14 - 12}{3 - 9} = \frac{2}{-6} = -\frac{1}{3}$$

$$\text{Slope of LN} = \frac{14 - 5}{3 - 0} = \frac{9}{3} = 3$$

$$(\text{Slope of MN}) \times (\text{Slope of LN})$$

$$= \left(-\frac{1}{3}\right) \times (3) = -1$$

$\therefore MN \perp LN$.

ΔLMN is a right angled triangle.

By Pythagoras theorem,

$$MN^2 + LN^2 = LM^2$$

$$MN^2 = (3 - 9)^2 + (14 - 12)^2$$

$$= (-6)^2 + (2)^2$$

$$= 36 + 4 = 40$$

$$LN^2 = (3 - 0)^2 + (14 - 5)^2$$

$$= (3)^2 + (9)^2$$

$$= 9 + 81 = 90$$

$$LM^2 = (9 - 0)^2 + (12 - 5)^2$$

$$= (9)^2 + (7)^2$$

$$= 81 + 49 = 130$$

$$MN^2 + LN^2 = 40 + 90$$

$$= 130 = LM^2.$$

Hence it is satisfied.

6. **Show that the given points form a parallelogram: A(2.5, 3.5), B(10, -4), C(2.5, -2.5) and D(-5, 5)**

Solution:

A(2.5, 3.5) B(10, -4),

$$\text{Slope of AB} = \frac{y_2 - y_1}{x_2 - x_1}$$

$$= \frac{-4 - 3.5}{10 - 2.5} = -\frac{7.5}{7.5} = -1$$

C(2.5, -2.5), D(-5, 5),

$$\text{Slope of CD} = \frac{5 - (-2.5)}{-5 - 2.5}$$

$$= \frac{5 + 2.5}{-7.5} = \frac{7.5}{-7.5} = -1$$

\therefore Slope of AB = Slope of CD.

So $AB \parallel CD$.

B(10, -4), C(2.5, -2.5),

$$\text{Slope of BC} = \frac{-2.5 - (-4)}{2.5 - 10}$$

$$= \frac{-2.5 + 4}{-7.5} = \frac{1.5}{-7.5} \times \frac{10}{10}$$

$$= \frac{15}{-75} = -\frac{1}{5}$$

A(2.5, 3.5), D(-5, 5),

$$\text{Slope of AD} = \frac{5 - (3.5)}{-5 - 2.5}$$

$$= \frac{1.5}{-7.5} = \frac{1.5}{-7.5} \times \frac{10}{10}$$

$$= \frac{15}{-75} = -\frac{1}{5}$$

\therefore Slope of BC = Slope of AD.

So $BC \parallel AD$.

\therefore The given points form a parallelogram.

7. If the points A(2, 2), B(-2, -3), C(1, -3) and D(x, y) form a parallelogram then find the value of x and y.

Solution:

Given points A (2, 2), B(-2, -3), C (1, -3) and D(x, y) are form a parallelogram.

Then AB \parallel CD and BC \parallel AD

\therefore Slope of AD = Slope of BC

$$\Rightarrow \frac{y-2}{x-2} = \frac{-3+3}{1+2} \Rightarrow \frac{y-2}{x-2} = 0$$

$$\Rightarrow y-2 = 0$$

$$\Rightarrow y = 2$$

Slope of CD = Slope of AB

$$\Rightarrow \frac{y-(-3)}{x-1} = \frac{-3-2}{-2-2}$$

$$\Rightarrow \frac{y+3}{x-1} = \frac{-5}{-4}$$

$$\Rightarrow \frac{5}{x-1} = \frac{5}{4}$$

$$\Rightarrow x-1 = 4 \Rightarrow x = 5$$

$$\therefore x = 5, y = 2$$

8. Let A(3, -4), B(9, -4), C(5, -7) and D(7, -7). Show that ABCD is a trapezium.

Solution:

If the given vertices A(3, -4), B(9, -4), C(5, -7) and D(7, -7) are form a trapezium then its only one pair of opposite sides are parallel.

$$\text{Slope of AB} = \frac{-4-(-4)}{9-3} = 0 \text{ ----(1)}$$

$$\text{Slope of CD} = \frac{-7-(-7)}{7-5} = 0 \text{ ----(2)}$$

$$\text{Slope of BC} = \frac{-7-(-4)}{5-9} = \frac{-3}{-4} = \frac{3}{4} \text{ --(3)}$$

$$\text{Slope of AD} = \frac{-7+4}{7-3} = \frac{-3}{4} \text{ ----(4)}$$

$$(1) = (2) \text{ but } (3) \neq (4)$$

Hence, AB \parallel CD but BC \neq AD.

(\because BC is not parallel to AD)

\therefore The given points A, B, C and D are form a trapezium.

9. A quadrilateral has vertices at A(-4, -2), B(5, -1), C(6, 5) and D(-7, 6). Show that the mid-points of its sides form a parallelogram.

MAY-22

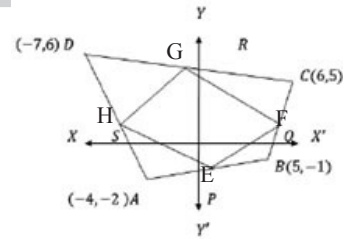
Solution:

The given points are A(-4, -2), B(5, -1), C(6, 5) and D(-7, 6) be form a quadrilateral E, F, G and H are the mid points of AB, BC, CD and AD respectively .

$$E = \left(\frac{-4+5}{2}, \frac{-2-1}{2} \right) = \left(\frac{1}{2}, \frac{-3}{2} \right)$$

$$F = \left(\frac{5+6}{2}, \frac{-1+5}{2} \right) = \left(\frac{11}{2}, 2 \right)$$

$$G = \left(\frac{6-7}{2}, \frac{5+6}{2} \right) = \left(\frac{-1}{2}, \frac{11}{2} \right)$$

$$H = \left(\frac{-4-7}{2}, \frac{-2+6}{2} \right) = \left(\frac{-11}{2}, 2 \right)$$

Slope of EF

$$\begin{aligned} & \frac{2 - \left(\frac{-3}{2} \right)}{\frac{11}{2} - \frac{1}{2}} = \frac{\frac{7}{2}}{\frac{10}{2}} = \frac{7}{10} \text{(1)} \end{aligned}$$

Slope of FG

$$\begin{aligned} & \frac{\frac{11}{2} - 2}{-\frac{1}{2} - \frac{11}{2}} = \frac{\frac{7}{2}}{\frac{-12}{2}} = \frac{7}{-12} \text{(2)} \end{aligned}$$

Slope of GH

$$\begin{aligned} & \frac{2 - \frac{11}{2}}{-\frac{11}{2} - \left(\frac{-1}{2} \right)} = \frac{\frac{-7}{2}}{\frac{-10}{2}} = \frac{7}{10} \text{(3)} \end{aligned}$$

Slope of HE

$$\begin{aligned} & \frac{\frac{3}{2} - 2}{\frac{1}{2} - \left(\frac{-11}{2} \right)} = \frac{\frac{-7}{2}}{\frac{12}{2}} = \frac{-7}{12} \text{(4)} \end{aligned}$$

Midpoint of EG = Midpoint of HF

$$\left[\left(\frac{1}{2} - \frac{1}{2} \right) \left(\frac{-3}{2} + \frac{11}{2} \right) \right] = \left[\left(\frac{11}{2} - \frac{11}{2}, 4 \right) \right]$$

$$[0, 4] = [0, 4]$$

\therefore Midpoints of the quadrilateral form a parallelogram.

10. A line makes positive intercepts on coordinate axes whose sum is 7 and it passes through $(-3, 8)$. Find its equation.

Solution:

If a and b are the intercepts then

$$a + b = 7 \text{ or } b = 7 - a$$

By intercept form $\frac{x}{a} + \frac{y}{b} = 1$

$$\text{We have, } \frac{x}{a} + \frac{y}{7-a} = 1$$

As this line pass through the point $(-3, 8)$, we have

$$\frac{-3}{a} + \frac{8}{7-a} = 1$$

$$\Rightarrow -3(7-a) + 8a = a(7-a)$$

$$-21 + 3a + 8a = 7a - a^2$$

$$\text{So, } a^2 - 7a + 11a - 21 = 0$$

Solving this equation

$$(a-3)(a+7) = 0$$

$$a = 3 \text{ or } a = -7$$

Since a is positive, we have $a = 3$ and

$$b = 7 - a = 7 - 3 = 4$$

$$\text{Hence, } \frac{x}{3} + \frac{y}{4} = 1$$

Therefore, $4x + 3y - 12 = 0$ is the required equation.

11. Find the equation of the median and altitude of $\triangle ABC$ through A where the vertices are $A(6, 2)$, $B(-5, -1)$ and $C(1, 9)$ **SEP-21**

Solution:

To find the equation of median through A

$$\text{Midpoint of } BC = D\left(\frac{-5+1}{2}, \frac{-1+9}{2}\right)$$

$$= D(-2, 4)$$

A(6, 2)

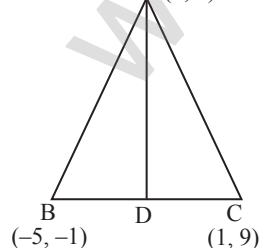

Equation of AD A(6, 2), D(-2, 4)

$$\frac{y-y_1}{y_2-y_1} = \frac{x-x_1}{x_2-x_1}$$

$$\frac{y-2}{4-2} = \frac{x-6}{-2-6}$$

$$\Rightarrow \frac{y-2}{4-2} = \frac{x-6}{-2-6}$$

$$\Rightarrow \frac{y-2}{2} = \frac{x-6}{-8}$$

$$\Rightarrow \frac{y-2}{1} = \frac{x-6}{-4}$$

$$\Rightarrow x-6 = -4y+8$$

$$\Rightarrow x+4y-14=0$$

To find the equation of Altitude through A

$B(-5, -1), C(1, 9)$

$$\text{Slope, } BC = \frac{y_2-y_1}{x_2-x_1} = \frac{9+1}{1+5}$$

$$= \frac{10}{6} = \frac{5}{3}$$

Hence, $AD \perp BC$,

$$\text{Slope, } AD = \frac{-3}{5} \text{ and } A(6, 2)$$

Equation of Altitude AD is

$$y-y_1 = m(x-x_1)$$

$$\Rightarrow y-2 = \frac{-3}{5}(x-6)$$

$$\Rightarrow 5y-10 = -3x+18$$

$$\Rightarrow 3x+5y-28=0$$

12. You are downloading a song. The percent y (in decimal form) of mega bytes remaining to get downloaded in x seconds is given by $y = -0.1x + 1$.

(i) find the total MB of the song.

(ii) after how many seconds will 75% of the song gets downloaded?

(iii) after how many seconds the song will be downloaded completely?

Solution:

i) Total MB of song can be obtained when, time = 0

$$\therefore x = 0, y = 1 \text{ MB}$$

ii) Time when 75% of song is downloaded.

$$\text{Remaining \%} = 25\% \Rightarrow y = 0.25$$

$$\Rightarrow 0.25 = -0.1x + 1$$

$$\Rightarrow 0.1x = 0.75 \Rightarrow x = \frac{0.75}{0.1}$$

$$x = 7.5 \Rightarrow \text{Required time : 7.5 Seconds}$$

iii) Song will be downloaded completely when remaining \% = 0% $\Rightarrow y = 0$

$$0 = -0.1x + 1$$

$$\Rightarrow x = 10$$

$$\Rightarrow \text{Required time : 10 Seconds}$$

13. Find the equation of a straight line parallel to Y axis and passing through the point of intersection of the lines $4x + 5y = 13$ and $x - 8y + 9 = 0$.

Solution:

$$\text{Given lines } 4x + 5y = -13 \quad \text{----(1)}$$

$$x - 8y + 9 = 0 \quad \text{----(2)}$$

To find the point of intersection, solve equation (1) and (2)

$$\begin{array}{r} x \quad y \quad 1 \\ 5 \times -13 \times 4 \times 5 \\ -8 \times 9 \times 1 \times -8 \\ \hline x \quad y \quad 1 \\ 45 - 104 = -13 - 36 = -32 - 5 \\ \hline x \quad y \quad 1 \\ -59 \quad -49 \quad -37 \end{array}$$

$$x = \frac{59}{37}, y = \frac{49}{37}$$

Therefore, the point of intersection

$$(x, y) = \left(\frac{59}{37}, \frac{49}{37} \right)$$

The equation of line parallel to Y axis is $x = c$.

$$\text{It passes through } (x, y) = \left(\frac{59}{37}, \frac{49}{37} \right).$$

$$\text{Therefore, } c = \frac{59}{37}.$$

$$\text{The equation of the line is } x = \frac{59}{37}$$

$$\text{gives } 37x - 59 = 0$$

14. The line joining the points A(0, 5) and B(4, 1) is a tangent to a circle whose centre C is at the point (4, 4) find

- (i) the equation of the line AB.
 (ii) the equation of the line through C which is perpendicular to the line AB.
 (iii) the coordinates of the point of contact of tangent line AB with the circle.

Solution:

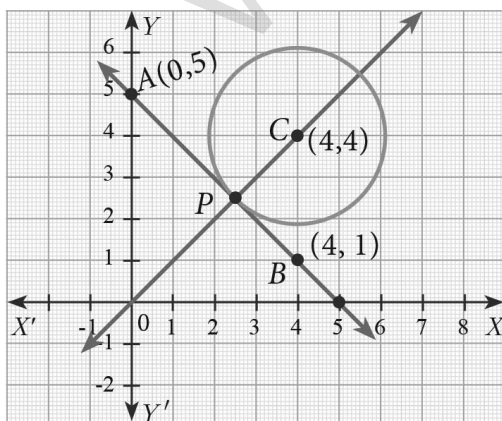

- i) Equation of line AB, A(0, 5) and B(4, 1)

$$\frac{y - y_1}{y_2 - y_1} = \frac{x - x_1}{x_2 - x_1}$$

$$\frac{y - 5}{1 - 5} = \frac{x - 0}{4 - 0}$$

$$4(y - 5) = -4x$$

$$\text{gives } y - 5 = -x$$

$$x + y - 5 = 0$$

- ii) The equation of a line which is perpendicular to the line AB $x + y - 5 = 0$ is $x - y + k = 0$.

Since it is passing through the point (4, 4) we have

$$4 - 4 + k = 0 \text{ gives, } k = 0$$

The equation of a line which is perpendicular to AB and through C is $x - y = 0$

- iii) The coordinate of the point of contact P of the tangent line AB with the circle is point of intersection of line : $x + y - 5 = 0$ and $x - y = 0$.

$$\text{Solving, we get } x = \frac{5}{2} \text{ and } y = \frac{5}{2}.$$

Therefore, the coordinate of the point of

$$\text{contact is } P\left(\frac{5}{2}, \frac{5}{2}\right)$$

15. Find the equation of a line passing through (6, -2) and perpendicular to the line joining the points (6, 7) and (2, -3).

Solution:

To find equation of the line joining points (6, 7) and (2, -3)

$$\frac{y - y_1}{y_2 - y_1} = \frac{x - x_1}{x_2 - x_1}$$

$$\Rightarrow \frac{y - 7}{-3 - 7} = \frac{x - 6}{2 - 6}$$

$$\Rightarrow \frac{y - 7}{-10} = \frac{x - 6}{-4}$$

$$\Rightarrow 4y - 28 = 10x - 60$$

$$\Rightarrow 10x - 4y - 32 = 0$$

$$\Rightarrow 5x - 2y - 16 = 0 \dots(1)$$

The equation (1) is perpendicular to

$$-2x - 5y + k = 0 \dots(2)$$

The equation (2) passing through (6, -2)

$$\therefore (2) \Rightarrow -2(6) - 5(-2) + k = 0$$

$$-12 + 10 + k = 0 \Rightarrow k = 2$$

$$\therefore \text{The required equation } -2x - 5y + 2 = 0$$

$$\Rightarrow 2x + 5y - 2 = 0$$

16. A(-3, 0) B(10, -2) and C(12, 3) are the vertices of $\triangle ABC$. Find the equation of the altitude through A and B.

Solution:

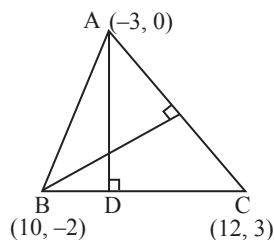

B(10, -2) C(12, 3)

$$\text{Slope of BC} = \frac{y_2 - y_1}{x_2 - x_1} = \frac{3 + 2}{12 - 10} = \frac{5}{2}$$

$BC \perp AD$

$$\therefore \text{Slope of AD} = -\frac{2}{5} \quad A(-3, 0)$$

The equation of the perpendicular line drawn from A to the opposite side of the triangle

$$y - y_1 = m(x - x_1)$$

$$y - 0 = -\frac{2}{5}(x + 3)$$

$$5y = -2x - 6$$

$$2x + 5y + 6 = 0$$

A(-3, 0) C(12, 3)

$$\text{Slope of AC} = \frac{3 - 0}{12 - (-3)} = \frac{3}{15} = \frac{1}{5}$$

$AC \perp BE$

B(10, -2) Slope of BE = -5

The equation of the perpendicular line drawn from B to the opposite side of the triangle

$$y - y_1 = m(x - x_1)$$

$$y + 2 = -5(x - 10)$$

$$y + 2 = -5x + 50$$

$$5x + y - 48 = 0$$

17. Find the equation of the perpendicular bisector of the line joining the points A(-4, 2) and B(6, -4).

Solution:

To find equation of the line joining the points

A(-4, 2) and B(6, -4)

$$\Rightarrow \frac{y - 2}{-4 - 2} = \frac{x - (-4)}{6 - (-4)}$$

$$\Rightarrow \frac{y - 2}{-6} = \frac{x + 4}{10}$$

$$\Rightarrow 10y - 20 = -6x - 24$$

$$\Rightarrow 6x + 10y + 4 = 0$$

$$\Rightarrow 3x + 5y + 2 = 0$$

..... (1)

Equation (1) is perpendicular to

$$5x - 3y + k = 0 \quad \dots (2)$$

Equation (2) is passing through the midpoints of AB

$$\text{Midpoint of AB} = \left(\frac{-4 + 6}{2}, \frac{2 - 4}{2} \right)$$

$$= (1, -1)$$

$$\therefore (2) \Rightarrow 5(1) - 3(-1) + k = 0$$

$$\Rightarrow 5 + 3 + k = 0$$

$$\Rightarrow k = -8$$

Hence, the Required Equation is

$$5x - 3y - 8 = 0$$

18. Find the equation of a straight line through the intersection of lines $7x + 3y = 10$, $5x - 4y = 1$ and parallel to the line $13x + 5y + 12 = 0$

Solution:

$$13x + 5y + 12 = 0$$

$$\text{Slope} = \frac{-\text{coefficient of } x}{\text{coefficient of } y}$$

$$m = -\frac{13}{5}$$

$$7x + 3y = 10 \quad \dots (1)$$

$$5x - 4y = 1 \quad \dots (2)$$

$$(1) \times 5 \Rightarrow 35x + 15y = 50$$

$$(2) \times 7 \Rightarrow 35x - 28y = 7 \quad (-)$$

$$43y = 43$$

$$y = 1$$

Substitute $y = 1$ in equation (1)

$$7x + 3(1) = 10$$

$$7x = 10 - 3$$

$$\Rightarrow 7x = 7$$

$$x = 1$$

$$\text{Slope} = -\frac{13}{5}, \text{ Points}(1, 1)$$

$$y - y_1 = m(x - x_1)$$

$$y - 1 = -\frac{13}{5}(x - 1)$$

$$\Rightarrow 5y - 5 = -13x + 13$$

$$13x + 5y - 18 = 0$$

\therefore The required equation $13x + 5y - 18 = 0$

19. Find the equation of a straight line through the intersection of lines $5x-6y=2$, $3x+2y=10$ and perpendicular to the line $4x-7y+13=0$

Solution:

$$5x - 6y = 2 \quad \text{---- (1)}$$

$$3x + 2y = 10 \quad \text{---- (2)}$$

$$(1) \times 1 \Rightarrow 5x - 6y = 2$$

$$(2) \times 3 \Rightarrow 9x + 6y = 30$$

$$\hline 14x = 32$$

$$x = \frac{32}{14}$$

$$x = \frac{16}{7}$$

Substitute the value of x in equation (1)

$$5 \left(\frac{16}{7} \right) - 6y = 2 \Rightarrow \frac{80}{7} - 6y = 2$$

$$\Rightarrow -6y = 2 - \frac{80}{7} \Rightarrow -6y = \frac{14-80}{7}$$

$$\Rightarrow -6y = -\frac{66}{7} \Rightarrow y = -\frac{66}{7 \times -6}$$

$$\Rightarrow y = \frac{11}{7}$$

\therefore Intersect point is $\left(\frac{16}{7}, \frac{11}{7} \right)$.

$$4x - 7y + 13 = 0$$

$$\text{Slope} = \frac{4}{7}$$

$$\text{Perpendicular Slope} = -\frac{7}{4}$$

$$\text{Slope} = m = -\frac{7}{4}. \text{ Points } \left(\frac{16}{7}, \frac{11}{7} \right)$$

\therefore The required equation

$$y - y_1 = m(x - x_1)$$

$$y - \frac{11}{7} = -\frac{7}{4} \left(x - \frac{16}{7} \right)$$

$$4y - 4 \left(\frac{11}{7} \right) = -7 \left(\frac{7x-16}{7} \right)$$

$$4y - \frac{44}{7} = -7x + 16$$

$$28y - 44 = -49x + 112$$

$$49x + 28y - 156 = 0$$

20. Find the equation of a straight line joining the point of intersection of $3x+y+2=0$ and $x-2y-4=0$ to the point of intersection of $7x-3y=-12$ and $2y=x+3$

Solution:

$$3x + y + 2 = 0 \quad \text{----(1)}$$

$$\text{and } x - 2y - 4 = 0 \quad \text{----(2)}$$

$$(1) \times 2 + (2) \Rightarrow 6x + 2y + 4 = 0$$

$$x - 2y - 4 = 0 \quad (+)$$

$$\hline 7x = 0 \Rightarrow x = 0$$

Substitute $x = 0$ in equation (2)

$$\Rightarrow -2y = 4 \Rightarrow y = -2$$

Point of Intersection $(0, -2)$

To find the intersection point,

$$7x - 3y = -12 \quad \text{----(3)}$$

$$x - 2y = -3 \quad \text{----(4)}$$

$$(3) - (4) \times 7 \Rightarrow 7x - 3y = -12$$

$$7x - 14y = -21 \quad (-)$$

$$\hline 11y = 9$$

$$\Rightarrow y = \frac{9}{11}$$

Substitute $y = \frac{9}{11}$ in equation (4)

$$\Rightarrow x = -\frac{18}{11} = -3$$

$$\Rightarrow x = -3 + \frac{18}{11} = -\frac{15}{11}$$

Point of Intersection $\left(-\frac{15}{11}, \frac{9}{11} \right)$

The required equation of the line joining

the points $(0, -2)$ and $\left(-\frac{15}{11}, \frac{9}{11} \right)$

Two points form :

$$\frac{y - y_1}{y_2 - y_1} = \frac{x - x_1}{x_2 - x_1}$$

$$\Rightarrow \frac{y - (-2)}{\frac{9}{11} - (-2)} = \frac{x - 0}{-\frac{15}{11} - 0}$$

$$\Rightarrow \frac{y + 2}{\frac{31}{11}} = \frac{x}{-\frac{15}{11}}$$

$$\Rightarrow -\frac{15}{11} (y + 2) = \frac{31}{11} (x)$$

$$\Rightarrow -15y - 30 = 31x$$

$$\Rightarrow 31x + 15y + 30 = 0$$

21. Find the equation of a straight line through the point of intersection of the lines $8x+3y=18$, $4x+5y=9$ and bisecting the line segment joining the points $(5, -4)$ and $(-7, 6)$.

Solution:

To find the intersecting point of the lines

$$8x + 3y = 18 \quad \text{----(1)}$$

$$4x + 5y = 9 \quad \text{----(2)}$$

$$(1) - (2) \times 2 \Rightarrow 8x + 3y = 18$$

$$8x + 10y = 18 \quad (-)$$

$$\hline -7y = 0 \Rightarrow y = 0$$

$$y = 0 \quad (2) \Rightarrow 4x = 9 \Rightarrow x = \frac{9}{4}$$

Point of Intersection $\left(\frac{9}{4}, 0\right)$
 $(5, -4)$ and $(-7, 6)$

$$\text{Midpoint} = \left(\frac{5-7}{2}, \frac{-4+6}{2}\right) = (-1, 1)$$

The required equation of the line joining
 the points $\left(\frac{9}{4}, 0\right)$ and $(-1, 1)$

$$\frac{y - y_1}{y_2 - y_1} = \frac{x - x_1}{x_2 - x_1}$$

$$\Rightarrow \frac{y - 0}{1 - 0} = \frac{x - \frac{9}{4}}{-1 - \frac{9}{4}}$$

$$\Rightarrow \frac{y}{1} = \frac{4x - 9}{-13}$$

$$\Rightarrow -13y = 4x - 9$$

$$\Rightarrow 4x + 13y - 9 = 0$$

6

Trigonometry

2 Marks

STAGE 2

1. Prove that $\tan^2\theta - \sin^2\theta = \tan^2\theta \sin^2\theta$

Solution:

$$\begin{aligned}\tan^2\theta - \sin^2\theta &= \tan^2\theta - \frac{\sin^2\theta}{\cos^2\theta} \cdot \cos^2\theta \\ &= \tan^2\theta(1 - \cos^2\theta) = \tan^2\theta \sin^2\theta\end{aligned}$$

2. Prove that $\frac{\sin A}{1 + \cos A} + \frac{\sin A}{1 - \cos A} = 2\operatorname{cosec}A$

Solution:

$$\begin{aligned}\frac{\sin A}{1 + \cos A} + \frac{\sin A}{1 - \cos A} &= \frac{\sin A(1 - \cos A) + \sin A(1 + \cos A)}{(1 + \cos A)(1 - \cos A)} \\ &= \frac{\sin A - \sin A \cos A + \sin A + \sin A \cos A}{1 - \cos^2 A} \\ &= \frac{2\sin A}{1 - \cos^2 A} = \frac{2\sin A}{\sin^2 A} = \frac{2}{\sin A} = 2\operatorname{cosec}A\end{aligned}$$

3. Prove that $\sec\theta - \cos\theta = \tan\theta \sin\theta$

Solution:

$$\begin{aligned}\text{LHS} &= \sec\theta - \cos\theta \\ &= \frac{1}{\cos\theta} - \cos\theta = \frac{1 - \cos^2\theta}{\cos\theta} = \frac{\sin^2\theta}{\cos\theta} \\ &= \frac{\sin\theta}{\cos\theta} \cdot \sin\theta = \tan\theta \sin\theta \\ \therefore \text{LHS} &= \text{RHS}\end{aligned}$$

4. Prove that $\frac{\sec\theta}{\sin\theta} - \frac{\sin\theta}{\cos\theta} = \cot\theta$

Solution:

$$\begin{aligned}\frac{\sec\theta}{\sin\theta} - \frac{\sin\theta}{\cos\theta} &= \frac{1}{\cos\theta \sin\theta} - \frac{\sin\theta}{\cos\theta} \\ &= \frac{1}{\sin\theta \cos\theta} - \frac{\sin\theta}{\cos\theta} \\ &= \frac{1 - \sin^2\theta}{\sin\theta \cos\theta} = \frac{\cos^2\theta}{\sin\theta \cos\theta} \\ &= \cot\theta\end{aligned}$$

5. Prove the following identities.

(i) $\cot\theta + \tan\theta = \sec\theta \operatorname{cosec}\theta$

Solution:

$$\begin{aligned}\text{LHS} &= \cot\theta + \tan\theta \\ &= \frac{\cos\theta}{\sin\theta} + \frac{\sin\theta}{\cos\theta}\end{aligned}$$

$$\begin{aligned}&= \frac{\cos^2\theta + \sin^2\theta}{\sin\theta \cos\theta} \\ &= \frac{1}{\sin\theta \cos\theta} = \sec\theta \operatorname{cosec}\theta\end{aligned}$$

$\therefore \text{LHS} = \text{RHS}.$

(ii) $\tan^4\theta + \tan^2\theta = \sec^4\theta - \sec^2\theta$

Solution:

$$\begin{aligned}\text{LHS} &= \tan^4\theta + \tan^2\theta = \tan^2\theta(\tan^2\theta + 1) \\ &= \tan^2\theta (\sec^2\theta) (\because 1 + \tan^2\theta = \sec^2\theta) \\ &= (\sec^2\theta - 1)(\sec^2\theta) \quad (\because \tan^2\theta = \sec^2\theta - 1) \\ &= \sec^4\theta - \sec^2\theta \\ \therefore \text{LHS} &= \text{RHS}\end{aligned}$$

6. Prove the following identities.

(i) $\frac{1 - \tan^2\theta}{\cot^2\theta - 1} = \tan^2\theta$

Solution:

$$\begin{aligned}\text{L.H.S} &= \frac{1 - \tan^2\theta}{\cot^2\theta - 1} = \frac{1 - \frac{\sin^2\theta}{\cos^2\theta}}{\frac{\cos^2\theta}{\sin^2\theta} - 1} \\ &= \frac{\cos^2\theta - \sin^2\theta}{\cos^2\theta} \cdot \frac{\sin^2\theta}{\cos^2\theta - \sin^2\theta} \\ &= \frac{\cos^2\theta - \sin^2\theta}{\cos^2\theta} \times \frac{\sin^2\theta}{\cos^2\theta - \sin^2\theta} \\ &= \tan^2\theta\end{aligned}$$

$\therefore \text{LHS} = \text{RHS}$

(ii) $\frac{\cos\theta}{1 + \sin\theta} = \sec\theta - \tan\theta$

Solution:

$$\begin{aligned}\text{LHS} &= \frac{\cos\theta}{1 + \sin\theta} \times \frac{1 - \sin\theta}{1 - \sin\theta} \\ &= \frac{\cos\theta(1 - \sin\theta)}{1 - \sin^2\theta} = \frac{\cos\theta(1 - \sin\theta)}{\cos^2\theta} \\ &= \frac{1 - \sin\theta}{\cos\theta} = \frac{1}{\cos\theta} - \frac{\sin\theta}{\cos\theta} \\ &= \sec\theta - \tan\theta\end{aligned}$$

7. Prove the following identities.

(i) $\sec^6\theta = \tan^6\theta + 3\tan^2\theta \sec^2\theta + 1$

Solution:

$$\text{LHS} = \sec^6\theta = (\sec^2\theta)^3$$

$$\begin{aligned}
 &= (\tan^2\theta + 1)^3 \quad (\because 1 + \tan^2\theta = \sec^2\theta) \\
 &\quad (\because (x+y)^3 = x^3 + 3x^2y + 3xy^2 + y^3) \\
 (\tan^2\theta + 1)^3 &= (\tan^2\theta)^3 + 3(\tan^2\theta)^2(1) + \\
 &\quad 3\tan^2\theta(1)^2 + (1)^3 \\
 &= \tan^6\theta + 3\tan^4\theta + 3\tan^2\theta + 1 \\
 &= \tan^6\theta + 3\tan^2\theta(\tan^2\theta + 1) + 1 \\
 &= \tan^6\theta + 3\tan^2\theta\sec^2\theta + 1 \\
 &= \text{RHS.}
 \end{aligned}$$

Hence Proved

$$\begin{aligned}
 \text{(ii)} \quad &(\sin\theta + \sec\theta)^2 + (\cos\theta + \text{cosec}\theta)^2 \\
 &= 1 + (\sec\theta + \text{cosec}\theta)^2
 \end{aligned}$$

Solution:

$$\begin{aligned}
 \text{LHS} &= (\sin\theta + \sec\theta)^2 + (\cos\theta + \text{cosec}\theta)^2 \\
 &= \sin^2\theta + \sec^2\theta + 2\sin\theta\sec\theta + \cos^2\theta \\
 &\quad + \text{cosec}^2\theta + 2\cos\theta\text{cosec}\theta \\
 &= \sin^2\theta + \cos^2\theta + \sec^2\theta + \text{cosec}^2\theta + 2\tan\theta + \\
 &\quad 2\cot\theta \\
 &= 1 + \sec^2\theta + \text{cosec}^2\theta + 2(\tan\theta + \cot\theta) \\
 [\because \tan\theta + \cot\theta &= \frac{\sin\theta}{\cos\theta} + \frac{\cos\theta}{\sin\theta} = \frac{\sin^2\theta + \cos^2\theta}{\sin\theta\cos\theta} \\
 &= \sec\theta\text{cosec}\theta] \\
 &= 1 + \sec^2\theta + \text{cosec}^2\theta + 2\sec\theta\text{cosec}\theta \\
 &= 1 + (\sec\theta + \text{cosec}\theta)^2 = \text{RHS.}
 \end{aligned}$$

Hence Proved

8. Prove the following identities.

$$\text{(i)} \quad \sec^4\theta (1 - \sin^4\theta) - 2\tan^2\theta = 1$$

Solution:

$$\begin{aligned}
 \text{LHS} &= \left(\frac{1}{\cos^4\theta}\right) (1 + \sin^2\theta)(1 - \sin^2\theta) - 2\tan^2\theta \\
 &= \left(\frac{1}{\cos^4\theta}\right) (1 + \sin^2\theta)\cos^2\theta - 2\tan^2\theta \\
 &= \frac{1 + \sin^2\theta}{\cos^2\theta} - \frac{2\sin^2\theta}{\cos^2\theta} \\
 &= \frac{1 + \sin^2\theta - 2\sin^2\theta}{\cos^2\theta} \\
 &= \frac{1 - \sin^2\theta}{\cos^2\theta} = \frac{\cos^2\theta}{\cos^2\theta} \\
 &= 1 = \text{RHS.}
 \end{aligned}$$

Hence Proved

$$\text{(ii)} \quad \frac{\cot\theta - \cos\theta}{\cot\theta + \cos\theta} = \frac{\text{cosec}\theta - 1}{\text{cosec}\theta + 1}$$

Solution:

$$\text{LHS} = \frac{\cot\theta - \cos\theta}{\cot\theta + \cos\theta} = \frac{\frac{\cos\theta}{\sin\theta} - \cos\theta}{\frac{\cos\theta}{\sin\theta} + \cos\theta}$$

$$\begin{aligned}
 &= \frac{\cos\theta \left[\frac{1}{\sin\theta} - 1 \right]}{\cos\theta \left[\frac{1}{\sin\theta} + 1 \right]} \\
 &= \frac{\text{cosec}\theta - 1}{\text{cosec}\theta + 1} = \text{RHS}
 \end{aligned}$$

Hence Proved

5 Marks

STAGE 2

1. If cosecθ + cotθ = P, then prove that

$$\cos\theta = \frac{P^2 - 1}{P^2 + 1}$$

Solution:

$$\text{cosec}\theta + \cot\theta = P \quad \dots (1)$$

$$\text{cosec}\theta - \cot\theta = 1/P \quad \dots (2)$$

$$(1) + (2) \Rightarrow 2 \text{ cosec}\theta = P + \frac{1}{P}$$

$$2 \text{ cosec}\theta = \frac{P^2 + 1}{P} \quad \dots (3)$$

$$(1) - (2) \Rightarrow 2 \cot\theta = P - \frac{1}{P}$$

$$2 \cot\theta = \frac{P^2 - 1}{P} \quad \dots (4)$$

$$(4) / (3) \Rightarrow \frac{2 \cot\theta}{2 \text{ cosec}\theta} = \frac{\frac{P^2 - 1}{P}}{\frac{P^2 + 1}{P}}$$

$$\frac{\cot\theta}{\text{cosec}\theta} = \frac{P^2 - 1}{P^2 + 1}$$

$$\frac{\cos\theta}{\sin\theta} \times \sin\theta = \frac{P^2 - 1}{P^2 + 1}$$

$$\cos\theta = \frac{P^2 - 1}{P^2 + 1}$$

Hence Proved

2. Prove that

$$\left(\frac{\cos^3 A - \sin^3 A}{\cos A - \sin A} \right) - \left(\frac{\cos^3 A + \sin^3 A}{\cos A + \sin A} \right) = 2 \sin A \cos A$$

Solution:

$$\left(\frac{\cos^3 A - \sin^3 A}{\cos A - \sin A} \right) - \left(\frac{\cos^3 A + \sin^3 A}{\cos A + \sin A} \right)$$

$$= \left(\frac{(\cos A - \sin A)(\cos^2 A + \sin^2 A + \cos A \sin A)}{\cos A - \sin A} \right)$$

$$- \left(\frac{(\cos A + \sin A)(\cos^2 A + \sin^2 A - \cos A \sin A)}{\cos A + \sin A} \right)$$

$$[\because a^3 - b^3 = (a-b)(a^2 + b^2 + ab)]$$

$$\begin{aligned}
 & a^3 + b^3 = (a+b)(a^2 + b^2 - ab)] \\
 & = (1 + \cos A \sin A) - (1 - \cos A \sin A) \\
 & = 1 + \cos A \sin A - 1 + \cos A \sin A \\
 & = 2 \cos A \sin A
 \end{aligned}$$

3. Prove the following identities.

$$\frac{\sin^3 A + \cos^3 A}{\sin A + \cos A} + \frac{\sin^3 A - \cos^3 A}{\sin A - \cos A} = 2$$

Solution:

Here $x = \sin A$, $y = \cos A$

$$\text{LHS} = \frac{\sin^3 A + \cos^3 A}{\sin A + \cos A} + \frac{\sin^3 A - \cos^3 A}{\sin A - \cos A}$$

$$\because x^3 + y^3 = (x+y)(x^2 - xy + y^2)$$

$$x^3 - y^3 = (x-y)(x^2 + xy + y^2)$$

$$= \frac{(\sin A + \cos A)(\sin^2 A - \sin A \cos A + \cos^2 A)}{\sin A + \cos A}$$

$$+ \frac{(\sin A - \cos A)(\sin^2 A + \sin A \cos A + \cos^2 A)}{\sin A - \cos A}$$

$$= \sin^2 A - \sin A \cos A + \cos^2 A + \sin^2 A + \sin A \cos A + \cos^2 A$$

$$= 2(\sin^2 A + \cos^2 A) \quad (\because \sin^2 A + \cos^2 A = 1)$$

$$= 2 = \text{RHS}$$

Hence Proved.

4. Two ships are sailing in the sea on either sides of a lighthouse. The angle of elevation of the top of the lighthouse as observed from the ships are 30° and 45° respectively. If the lighthouse is 200 m high, find the distance between the two ships. ($\sqrt{3} = 1.732$)

SEP-21

Solution:

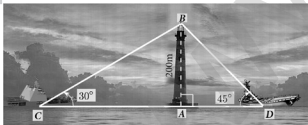

Let AB be the lighthouse.

Let C and D be the positions of the two ships.

Then, $AB = 200\text{m}$

$$\angle ACB = 30^\circ, \angle ADB = 45^\circ$$

$$\text{In right triangle BAC, } \tan 30^\circ = \frac{AB}{AC}$$

$$\frac{1}{\sqrt{3}} = \frac{200}{AC} \text{ gives, } AC = 200\sqrt{3} \text{ ---(1)}$$

$$\text{In right triangle BAD, } \tan 45^\circ = \frac{AB}{AD}$$

$$1 = \frac{200}{AD} \text{ gives } AD = 200 \text{ ---(2)}$$

$$\text{Now, } CD = AC + AD = 200\sqrt{3} + 200$$

[by (1) and (2)]

$$CD = 200(\sqrt{3} + 1) = 200 \times 2.732 = 546.4$$

Distance between two ships is 546.4m

5. From a point on the ground, the angles of elevation of the bottom and top of a tower fixed at the top of a 30 m high building are 45° and 60° respectively. Find the height of the tower. ($\sqrt{3} = 1.732$)

MAY-22

Solution:



$$\text{In } \triangle APB \quad \tan \theta = \frac{\text{opposite side}}{\text{Adjacent side}}$$

$$\tan 45^\circ = \frac{30}{BP} \Rightarrow 1 = \frac{30}{BP}$$

$$BP = 30\text{m}$$

$$\text{In } \triangle BPC \quad \tan 60^\circ = \frac{BC}{BP}$$

$$\sqrt{3} = \frac{h + 30}{30}$$

$$30\sqrt{3} = h + 30$$

$$h = 30\sqrt{3} - 30$$

$$= 30(1.732 - 1)$$

$$= 30(0.732)$$

$$= 21.960$$

6. A TV tower stands vertically on a bank of a canal. The tower is watched from a point on the other bank directly opposite to it. The angle of elevation of the top of the tower is 58° . From another point 20 m away from this point on the line joining this point to the foot of the tower, the angle of elevation of the top of the tower is 30° . Find the height of the tower and the width of the canal. ($\tan 58^\circ = 1.6003$)

Solution:

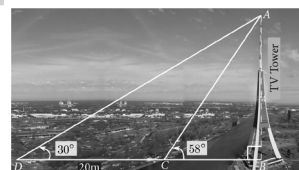

Let AB be the height of the TV Tower, BC be the Width of the canal, $CD = 20\text{m}$

In the right angled triangle ABC

$$\tan 58^\circ = \frac{AB}{BC}$$

$$1.6003 = \frac{AB}{BC} \quad \text{---(1)}$$

In the right angled triangle ABD

$$\tan 30^\circ = \frac{AB}{BD}$$

$$\frac{1}{\sqrt{3}} = \frac{AB}{BC + 20} \quad \text{---(2)}$$

Dividing (1) by (2) we get,

$$\frac{1.6003}{\frac{1}{\sqrt{3}}} = \frac{BC + 20}{BC}$$

$$1.732 \times 1.6003 = \frac{BC + 20}{BC}$$

$$2.7717 BC = BC + 20$$

$$2.7717 BC - BC = 20$$

$$BC[1.7717] = 20$$

$$BC = \frac{20}{1.7717} = 11.29 \text{ m}$$

$$1.6003 = \frac{AB}{11.29} \quad [\text{From (1)}]$$

$$AB = 18.07$$

Hence, the height of the tower is 17.99 m and the width of the canal is 11.29 m.

7. To a man standing outside his house, the angles of elevation of the top and bottom of a window are 60° and 45° respectively. If the height of the man is 180 cm and if he is 5 m away from the wall, what is the height of the window? ($\sqrt{3} = 1.732$)

Solution:

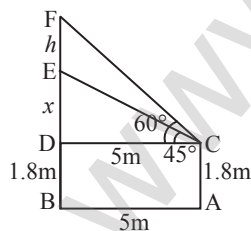

In figure, AC – A man Standing,

EF – Window, DF – House

From the figure,

$$EF = h, ED = x, DF = x + h$$

In $\triangle CDE$,

$$\tan 45^\circ = \frac{DE}{DC} \Rightarrow 1 = \frac{x}{5} \Rightarrow x = 5$$

In $\triangle CDF$,

$$\tan 60^\circ = \frac{DF}{DC} \Rightarrow \sqrt{3} = \frac{h + x}{5}$$

$$\Rightarrow h + x = \sqrt{3}(5)$$

$$\Rightarrow h = (5 \times \sqrt{3}) - 5$$

$$= 5[\sqrt{3} - 1] = 5[1.732 - 1]$$

$$= 5[0.732] = 3.66 \text{ m}$$

Hence, Height of the window = 3.66m

8. The top of a 15 m high tower makes an angle of elevation of 60° with the bottom of an electronic pole and angle of elevation of 30° with the top of the pole. What is the height of the electric pole?

Solution:

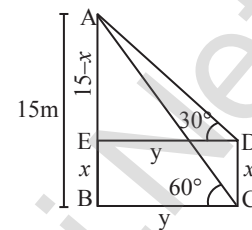

In figure AB – Electric Pole, CD – Tower

From the figure,

$$AB = 15, AE = 15 - x \text{ m,}$$

$$BE = CD = x, ED = y$$

In $\triangle AED$,

$$\tan 30^\circ = \frac{AE}{ED}$$

$$\Rightarrow \frac{1}{\sqrt{3}} = \frac{15 - x}{y}$$

$$y = (15 - x)\sqrt{3} \quad \text{---(1)}$$

In $\triangle ABC$,

$$\tan 60^\circ = \frac{AB}{BC} \Rightarrow \sqrt{3} = \frac{15}{y}$$

$$y = \frac{15}{\sqrt{3}} = \frac{15}{\sqrt{3}} \times \frac{\sqrt{3}}{\sqrt{3}} = 5\sqrt{3} \quad \text{---(2)}$$

$$(1) = (2) \Rightarrow (15 - x)\sqrt{3} = 5\sqrt{3}$$

$$15 - x = 5$$

$$\Rightarrow x = 10 \text{ m}$$

Hence, the height of the electric pole is 10m.

9. The horizontal distance between two buildings is 140m. The angle of depression of the top of the first building when seen from the top of the second building is 30° . If the height of the first building is 60m, find the height of the second building. ($\sqrt{3} = 1.732$).

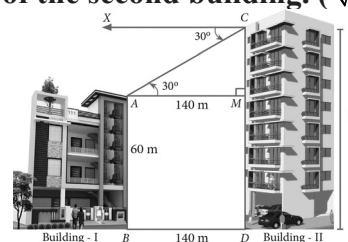

Solution:

The height of the first building AB = 60m.

Now, AB = MD = 60m.

Let the height of the second building.

AB = 60 m. Now, AB = MD = 60m

Now, AM = BD = 140m

From the diagram,

$\angle XCA = 30^\circ = \angle CAM$

In the right angled $\triangle AMC$,

$$\tan 30^\circ = \frac{CM}{AM}$$

$$\frac{1}{\sqrt{3}} = \frac{CM}{140}$$

$$\begin{aligned} CM &= \frac{140}{\sqrt{3}} = \frac{140}{\sqrt{3}} \times \frac{\sqrt{3}}{\sqrt{3}} \\ &= \frac{140\sqrt{3}}{3} = \frac{140 \times 1.732}{3} = 80.83 \end{aligned}$$

Now, h = CD = CM + MD

$$= 80.83 + 60 = 140.83 \text{ m}$$

Therefore, the height of the second building is 140.83 m

10. From the top of a tower 50 m high, the angles of depression of the top and bottom of a tree are observed to be 30° and 45° respectively. Find the height of the tree. ($\sqrt{3} = 1.732$)

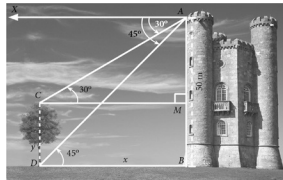
**Solution:**

Height of the tower AB = H = 50 m

Let the height of the tree = CD = y and BD = x

From the diagram, $\angle XAC = 30^\circ = \angle ACM$

$\angle XAD = 45^\circ = \angle ADB$

In the right angled triangle ABD,

$$\tan 45^\circ = \frac{AB}{BD}$$

$$1 = \frac{50}{x} \Rightarrow x = 50\text{m}$$

In the right angled triangle AMC,

$$\tan 30^\circ = \frac{AM}{CM}$$

$$\frac{1}{\sqrt{3}} = \frac{AM}{50} \quad [\because DB = CM]$$

$$\begin{aligned} AM &= \frac{50}{\sqrt{3}} = \frac{50\sqrt{3}}{3} \\ &= \frac{50 \times 1.732}{3} = 28.87\text{m} \end{aligned}$$

$$\begin{aligned} \therefore \text{Height of the tree} &= CD = MB = AB - AM \\ &= 50 - 28.87 = 21.13\text{m} \end{aligned}$$

11. A man is watching a boat speeding away from the top of a tower. The boat makes an angle of depression of 60° with the man's eye when at a distance of 200 m from the tower. After 10 seconds, the angle of depression becomes 45° . What is the approximate speed of the boat (in km / hr), assuming that it is sailing in still water? ($\sqrt{3} = 1.732$)

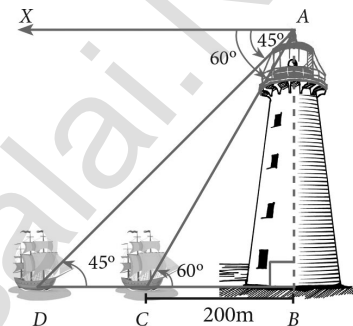
**Solution:**

Let AB be the tower.

Let C and D be the positions of the boat

$\angle XAC = 60^\circ = \angle ACB$ and

$\angle XAD = 45^\circ = \angle ADB$, BC = 200 m

In right triangle, ABC,

$$\tan 60^\circ = \frac{AB}{BC}$$

$$\text{gives } \sqrt{3} = \frac{AB}{200}$$

$$BC = 200\sqrt{3} \quad \dots (1)$$

In right triangle, ABD

$$\tan 45^\circ = \frac{AB}{BD}$$

$$\text{gives } 1 = \frac{200\sqrt{3}}{BD} \quad [\text{by (1)}]$$

We get, BD = $200\sqrt{3}$

$$\begin{aligned} \text{Now, } CD &= 200\sqrt{3} - 200 \\ &= 200(\sqrt{3} - 1) = 146.4 \end{aligned}$$

It is given that the distance CD is covered in 10 seconds.

That is, the distance of 146.4m is covered in 10 seconds.

$$\begin{aligned} \text{Therefore, speed of the boat} &= \frac{\text{distance}}{\text{time}} \\ &= \frac{146.4}{10} \\ &= 14.64 \text{ m/s} \end{aligned}$$

$$\begin{aligned} \text{gives } 14.64 \times \frac{3600}{1000} \text{ km / hr} \\ = 52.704 \text{ km / hr} \end{aligned}$$

12. An aeroplane at an altitude of 1800 m finds that two boats are sailing towards it in the same direction. The angles of depression of the boats as observed from the aeroplane are 60° and 30° respectively. Find the distance between the two boats. ($\sqrt{3} = 1.732$)

Solution:

In figure, A – An Aeroplane,
 B_1, B_2 are Two Boats
 From the figure, $AP = 1800\text{m}$,
 $PB_1 = y, B_1B_2 = x, PB_2 = x + y$

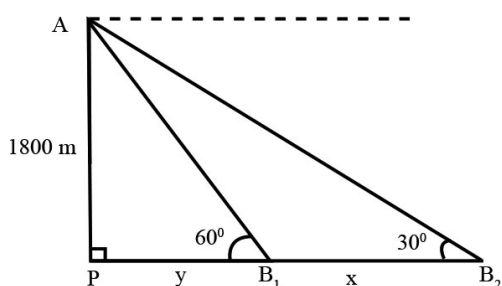

$$\begin{aligned} \text{In } \triangle APB_1, \tan 60^\circ &= \frac{AP}{PB_1} \\ \Rightarrow \sqrt{3} &= \frac{1800}{y} \\ \Rightarrow y &= \frac{1800}{\sqrt{3}} \\ &= \frac{1800}{\sqrt{3}} \times \frac{\sqrt{3}}{\sqrt{3}} = \frac{1800\sqrt{3}}{3} \\ &= 600\sqrt{3} \text{ m} \end{aligned}$$

$$\begin{aligned} \text{In } \triangle APB_2, \tan 30^\circ &= \frac{AP}{PB_2} \\ \Rightarrow \frac{1}{\sqrt{3}} &= \frac{1800}{x+y} \\ \Rightarrow x+y &= 1800\sqrt{3} \\ \Rightarrow x &= 1800\sqrt{3} - 600\sqrt{3} \\ \Rightarrow x &= 1200\sqrt{3} \text{ m} = 1200 \times 1.732 \\ &= 2078.4 \text{ m} \end{aligned}$$

Hence, the distance between the boats
 $= 2078.4 \text{ m}$

13. As observed from the top of a 60 m high lighthouse from the sea level, the angles of depression of two ships are 28° and 45° . If one ship is exactly behind the other on the same side of the lighthouse, find the distance between the two ships. ($\tan 28^\circ = 0.5317$)

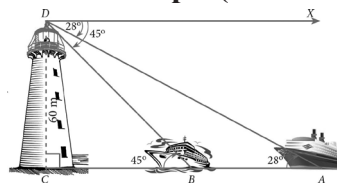
**Solution:**

Height of the Light house = $CD = 60\text{m}$

Position of the observer = D

From the Diagram $\angle XDA = 28^\circ = \angle DAC$ and
 $\angle XDB = 45^\circ = \angle DBC$

From the Triangle DCB, We have

$$\begin{aligned} \tan 45^\circ &= \frac{DC}{BC} \\ 1 &= \frac{60}{BC} \\ BC &= 60\text{m} \end{aligned}$$

From the Triangle DCA, we have

$$\tan 28^\circ = \frac{DC}{AC}$$

$$0.5317 = \frac{60}{AC}$$

$$AC = \frac{60}{0.5317}$$

$$AC = 112.85\text{m}$$

Distance between two ships

$$AB = AC - BC = 112.85 - 60 = 52.85\text{m}$$

14. From the top of a lighthouse, the angle of depression of two ships on the opposite sides of it are observed to be 30° and 60° . If the height of the lighthouse is h meters and the line joining the ships passes through the foot of the lighthouse, show that the distance between the ships is $\frac{4h}{\sqrt{3}}$ m.

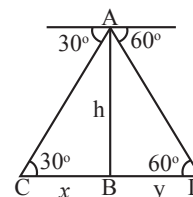
Solution:

C, D – Positions of the two ships

Height of the Light House $AB = h \text{ m}$

$$\text{In } \triangle ABC \quad \tan \theta = \frac{\text{opposite side}}{\text{Adjacent side}}$$

$$\tan 30^\circ = \frac{h}{x}$$

$$\frac{1}{\sqrt{3}} = \frac{h}{x}$$

$$x = h\sqrt{3}$$

$$\text{In } \triangle ABD \quad \tan 60^\circ = \frac{h}{y}$$

$$\sqrt{3} = \frac{h}{y}$$

$$y = \frac{h}{\sqrt{3}}$$

Distance between two ships

$$(x + y) = h\sqrt{3} + \frac{h}{\sqrt{3}}$$

$$d = \frac{4h}{\sqrt{3}} \text{ m}$$

15. A lift in a building of height 90 feet with transparent glass walls is descending from the top of the building. At the top of the building, the angle of depression to a fountain in the garden is 60° . Two minutes later, the angle of depression reduces to 30° . If the fountain is $30\sqrt{3}$ feet from the entrance of the lift, find the speed of the lift which is descending.

Solution:

In Figure, AC – Building, A – A lift at the top of the building

B – The lift two minutes later,

D = Fountain in the garden

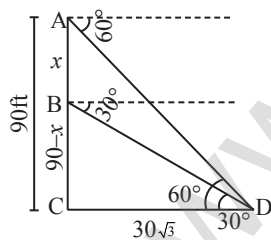

In the figure, AC = 90 feet,
 CD = $30\sqrt{3}$ feet, AB = x feet,
 BC = $90 - x$ feet

$$\text{In } \triangle BCD, \tan 30^\circ = \frac{BC}{CD}$$

$$\Rightarrow \frac{1}{\sqrt{3}} = \frac{90 - x}{30\sqrt{3}}$$

$$\Rightarrow 90 - x = 30$$

$$\therefore x = 60 \text{ feet}$$

Time taken by the lift from A to B

= 2 minutes

$$\text{Speed} = \frac{\text{distance}}{\text{time}}$$

$$\text{Speed} = \frac{60}{2} = 30 \text{ feet / minutes}$$

16. A pole 5 m high is fixed on the top of a tower. The angle of elevation of the top of the pole observed from a point 'A' on the ground is 60° and the angle of depression to the point 'A' from the top of the tower is 45° . Find the height of the tower. ($\sqrt{3} = 1.732$)

Solution:

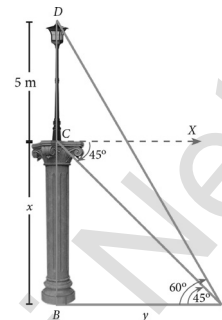

Let BC be the height of the tower and CD be the height of the pole.

Let 'A' be the point of observation.

Let BC = x and AB = y

From the diagram

$$\angle BAD = 60^\circ \text{ and } \angle XCA = 45^\circ = \angle BAC$$

In right angled $\triangle ABC$,

$$\tan 45^\circ = \frac{BC}{AB}$$

$$\Rightarrow 1 = \frac{x}{y} \Rightarrow x = y \quad \text{---(1)}$$

In right angled $\triangle ABD$

$$\tan 60^\circ = \frac{BD}{AB} = \frac{BC + CD}{AB}$$

$$\Rightarrow \sqrt{3} = \frac{x + 5}{y} \Rightarrow \sqrt{3}y = x + 5$$

We get, $\sqrt{3}x = x + 5$ [From (1)]

$$\sqrt{3}x - x = 5$$

$$x[\sqrt{3} - 1] = 5$$

$$x = \frac{5}{\sqrt{3} - 1}$$

$$= \frac{5}{\sqrt{3} - 1} \times \frac{\sqrt{3} + 1}{\sqrt{3} + 1}$$

$$= \frac{5(1.732 + 1)}{2} = \frac{5 \times 2.732}{2}$$

$$= 5 \times 1.366 = 6.83$$

Hence, height of the tower is 6.83 m

17. From the top of a tree of height 13 m the angle of elevation and depression of the top and bottom of another tree are 45° and 30°

respectively. Find the height of the second tree. ($\sqrt{3} = 1.732$)

Solution:

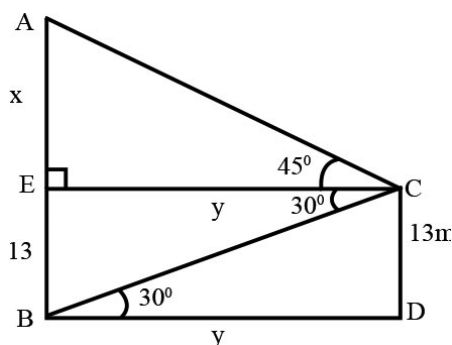

Let AB - height of second tree and
CD - height of the first tree = 13

$$\begin{aligned} \text{In } \angle AEC, \tan 45^\circ &= \frac{AE}{CE} \\ 1 &= \frac{x}{y} \\ x &= y \end{aligned} \quad \dots (1)$$

$$\begin{aligned} \text{In } \angle BCD, \tan 30^\circ &= \frac{CD}{BD} \\ \frac{1}{\sqrt{3}} &= \frac{13}{y} \\ y &= 13\sqrt{3} \end{aligned}$$

From (1) $x = y = 13\sqrt{3}$
Height of the second tree,

$$\begin{aligned} AB &= AE + EB \\ &= x + 13 \\ &= 13\sqrt{3} + 13 \\ &= 13[\sqrt{3} + 1] \\ &= 13[1 + 1.732] \\ &= 13[2.732] \\ &= 35.52 \text{ m} \end{aligned}$$

\therefore Height of the second tree = 35.52 m

18. A man is standing on the deck of a ship, which is 40 m above water level. He observes the angle of elevation of the top of a hill as 60° and the angle of depression of the base of the hill as 30° . Calculate the distance of the hill from the ship and the height of the hill. ($\sqrt{3} = 1.732$)

Solution:

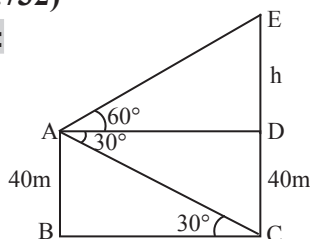

AB - Ship, CE - Hill

From the figure,

$$\begin{aligned} AB &= CD = 40\text{m}, BC = AD = x, DE = h, \\ CE &= 40 + h \end{aligned}$$

$$\begin{aligned} \text{In } \triangle ABC \tan 30^\circ &= \frac{AB}{BC} = \frac{1}{\sqrt{3}} = \frac{40}{x} \\ \Rightarrow x &= 40 \times \sqrt{3} \end{aligned} \quad \dots (1)$$

$$\begin{aligned} \text{In } \triangle ADE \tan 60^\circ &= \frac{DE}{AD} = \sqrt{3} = \frac{h}{x} \\ \Rightarrow h &= x \times \sqrt{3} = 40 \times \sqrt{3} \times \sqrt{3} = 120 \text{ m} \\ \therefore \text{Height of the hill} &= 40 + 120 = 160 \text{ m} \end{aligned}$$

The distance of the hill from the ship is
 $\Rightarrow x = 40 \times \sqrt{3} = 69.28 \text{ m}$

19. If the angle of elevation of a cloud from a point 'h' metres above a lake is θ_1 and the angle of depression of its reflection in the lake is θ_2 . Prove that the height that the cloud is located from the ground is $\frac{h(\tan \theta_1 + \tan \theta_2)}{\tan \theta_2 - \tan \theta_1}$.

Solution:

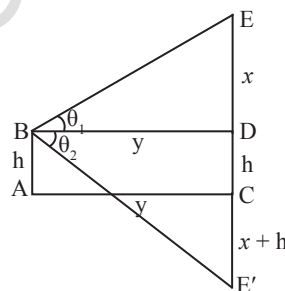

From the Figure BD - Surface of the Lake,
E - Cloud, E' - Reflection of cloud,
B - Observer

$$\begin{aligned} AB &= CD = h, BD = AC = y, ED = x, \\ CE &= CE' = h + x, DE' = x + 2h \end{aligned}$$

$$\begin{aligned} \text{In } \triangle BDE \tan \theta_1 &= \frac{DE}{BD} \\ \Rightarrow \tan \theta_1 &= \frac{x}{y} \\ \Rightarrow y &= \frac{x}{\tan \theta_1} \end{aligned} \quad \dots (1)$$

$$\begin{aligned} \text{In } \triangle BDE' \tan \theta_2 &= \frac{DE'}{BD} \\ \Rightarrow \tan \theta_2 &= \frac{x + 2h}{y} \\ \Rightarrow y &= \frac{x + 2h}{\tan \theta_2} \end{aligned} \quad \dots (2)$$

$$(1) = (2)$$

$$\Rightarrow \frac{x}{\tan \theta_1} = \frac{x+2h}{\tan \theta_2}$$

$$x \tan \theta_2 = x \tan \theta_1 + 2h \tan \theta_1$$

$$x(\tan \theta_2 - \tan \theta_1) = 2h \tan \theta_1$$

$$x = \frac{2h \tan \theta_1}{\tan \theta_2 - \tan \theta_1}$$

Height of the cloud from the ground,

$$CE = x + h$$

$$= \frac{2h \tan \theta_1}{\tan \theta_2 - \tan \theta_1} + h$$

$$= \frac{2h \tan \theta_1 + h \tan \theta_2 - h \tan \theta_1}{\tan \theta_2 - \tan \theta_1}$$

$$= \frac{h(\tan \theta_1 + \tan \theta_2)}{\tan \theta_2 - \tan \theta_1}$$

Hence Proved

20. The angle of elevation of the top of a cell phone tower from the foot of a high apartment is 60° and the angle of depression of the foot of the tower from the top of the apartment is 30° . If the height of the apartment is 50 m, find the height of the cell phone tower. According to radiations control norms, the minimum height of a cell phone tower should be 120 m. State if the height of the above mentioned cell phone tower meets the radiation norms.

Solution:

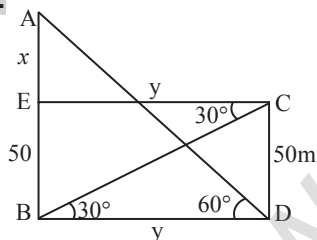

AB - Cell Phone Tower,

CD - Height of the apartment

From the figure, BE = CD = 50m,

AE = x, AB = 50 + x, BD = CE = y

$$\text{In } \triangle BCD, \tan 30^\circ = \frac{CD}{BD}$$

$$\Rightarrow \frac{1}{\sqrt{3}} = \frac{50}{y}$$

$$\Rightarrow y = 50 \times \sqrt{3} \quad \text{----(1)}$$

$$\text{In } \triangle ABD, \tan 60^\circ = \frac{AB}{BD}$$

$$= \sqrt{3} = \frac{50+x}{y}$$

$$\Rightarrow y = \frac{50+x}{\sqrt{3}} \quad \text{----(2)}$$

From (1), (2)

$$\frac{50+x}{\sqrt{3}} = 50 \times \sqrt{3}$$

$$50+x = 50 \times \sqrt{3} \times \sqrt{3} = 150 \text{ m}$$

$$\Rightarrow x = 150 - 50 = 100 \text{ m}$$

Height of the cellphone tower

$$= x+50 = 100 + 50 = 150 \text{ m}$$

Since, 150m > 120m. Yes the height of the tower does not meet the radiation norms.

21. The angles of elevation and depression of the top and bottom of a lamp post from the top of a 66 m high apartment are 60° and 30° respectively. Find

(i) The height of the lamp post.

(ii) The difference between height of the lamp post and the apartment.

(iii) The distance between the lamp post and the apartment. ($\sqrt{3} = 1.732$)

Solution:

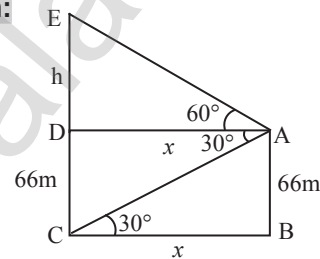

AB - Height of the apartment,

CE - Lamp Post

From the Figure, AB = CD = 66m,

DE = h, CE = 66+h, BC = AD = x

$$\text{In } \triangle ABC, \tan 30^\circ = \frac{AB}{BC}$$

$$\Rightarrow \frac{1}{\sqrt{3}} = \frac{66}{x}$$

$$\Rightarrow x = 66 \times \sqrt{3}$$

$$\text{In } \triangle ADE, \tan 60^\circ = \frac{ED}{AD}$$

$$\Rightarrow \sqrt{3} = \frac{h}{x} \Rightarrow h = \sqrt{3} \times x$$

$$= \sqrt{3} \times 66 \times \sqrt{3}$$

$$= 66 \times 3 = 198 \text{ m}$$

i) Let CE be the height of the lamp post

$$CE = 66 + h = 66 + 198 = 264 \text{ m}$$

ii) The difference between the height of the lamp post and the apartment is

$$CE - AB = 264 - 66 = 198 \text{ m}$$

iii) The distance between the lamp post and the apartment is x

$$x = 66 \sqrt{3} = 114.312 \text{ m}$$

7

Mensuration

2 Marks

STAGE 2

1. The curved surface area of a right circular cylinder of height 14 cm is 88 cm². Find the diameter of the cylinder.

Solution:

Given that, C.S.A. of the cylinder

$$= 88 \text{ sq. cm}$$

$$2\pi rh = 88$$

$$2 \times \frac{22}{7} \times r \times 14 = 88 \quad (h = 14 \text{ cm})$$

$$2r = \frac{88 \times 7}{22 \times 14} = 2$$

Therefore, diameter = 2 cm

2. A garden roller whose length is 3 m long and whose diameter is 2.8 m is rolled to level a garden. How much area will it cover in 8 revolutions?

Solution:Given that, diameter $d = 2.8$ m andheight = 3 m, radius $r = 1.4$ m

Area covered in one revolution

$$= \text{curved surface area of the cylinder}$$

$$= 2\pi rh \text{ sq. units}$$

$$= 2 \times \frac{22}{7} \times 1.4 \times 3$$

$$= 26.4$$

Area covered in 1 revolution = 26.4 m²

$$\text{Area covered in 8 revolutions} = 8 \times 26.4 = 211.2$$

Therefore, area covered is 211.2 m²

3. If the total surface area of a cone of radius 7 cm is 704 cm², then find its slant height.

Solution:

$$\text{Total Surface Area} = 704 \text{ cm}^2$$

$$\pi r (l + r) = 704$$

$$\frac{22}{7} \times 7 (l + 7) = 704$$

$$l + 7 = \frac{704}{22}$$

$$= \frac{64}{2} = 32$$

$$l + 7 = 32 \Rightarrow l = 32 - 7 = 25 \text{ cm}$$

Therefore, slant height of the cone is 25 cm.

4. Find the diameter of a sphere whose surface area is 154 m². SEP-20

Solution:Let r be the radius of the sphere.Given that, surface area of sphere = 154 m²

$$4\pi r^2 = 154$$

$$4 \times \frac{22}{7} \times r^2 = 154$$

$$\text{gives } r^2 = \frac{154}{4} \times \frac{7}{22}$$

$$r^2 = \frac{49}{4}$$

$$r = \frac{7}{2}$$

$$\text{Radius of sphere } r = \frac{7}{2} \text{ m;}$$

$$\text{Diameter of sphere } d = 7 \text{ m}$$

5. The radius of a spherical balloon increases from 12 cm to 16 cm as air being pumped into it. Find the ratio of the surface area of the balloons in the two cases. MAY-22

Solution:Let r_1 and r_2 be the radii of the balloons.

$$\text{Given that, } \frac{r_1}{r_2} = \frac{12}{16} = \frac{3}{4}$$

Ratio of C.S.A. of balloons

$$= \frac{4\pi r_1^2}{4\pi r_2^2} = \frac{r_1^2}{r_2^2} = \left(\frac{r_1}{r_2}\right)^2 = \left(\frac{3}{4}\right)^2 = \frac{9}{16}$$

Therefore, ratio of C.S.A. of balloons is 9:16.

6. The external radius and the length of a hollow wooden log are 16 cm and 13 cm respectively. If its thickness is 4 cm then find its T.S.A.

Solution:In hollow cylinder, $R = 16$ cm, $h = 13$ cm and W

$$= R - r \Rightarrow 4 = 16 - r \Rightarrow r = 12 \text{ cm}$$

$$\text{T.S.A} = 2\pi(R+r) (R - r + h) \text{ Sq.units}$$

$$= 2 \times \frac{22}{7} \times (16+12)(16 - 12 + 13)$$

$$= 2 \times \frac{22}{7} \times 28 \times 17$$

$$\text{T.S.A} = 2992 \text{ cm}^2$$

7. The radius of a sphere increases by 25%. Find the percentage increase in its surface area.

Solution:

When r is radius of the sphere, then surface area $= 4\pi r^2$ (1)

If r is increases by 25%

$$\Rightarrow \text{The new Radius } R = r + r \times \frac{25}{100}$$

$$\Rightarrow R = \frac{125r}{100} = \frac{5}{4}r$$

Now, Surfaced Area $= 4\pi R^2$

$$= 4\pi \left(\frac{25r^2}{16} \right)$$

$$= 4\pi \left(\frac{5r}{4} \right)^2$$

$$= \frac{\quad \times 25 \times \quad}{\quad} \dots\dots(2)$$

From (2) and (1)

Amount of increases Area

$$= \frac{25}{4} \pi r^2 - 4\pi r^2$$

$$= \pi r^2 \left(\frac{25-16}{4} \right) = \pi r^2 \left(\frac{9}{4} \right)$$

The Percentage of increase,

$$\text{Surface Area} = \frac{\frac{9}{4} \pi r^2}{4\pi r^2} \times 100$$

$$= \frac{9}{4} \times \frac{1}{4} \times 100 = 56.25\%$$

8. Find the volume of a cylinder whose height is 2 m and whose base area is 250 m². **SEP-21**

Solution:

Let r and h be the radius and height of the cylinder respectively.

Given that, height $h = 2$ m, base area $= 250$ m²

Now, volume of a cylinder $= \pi r^2 h$ cu. units

$$= \text{base area} \times h$$

$$= 250 \times 2 = 500 \text{ m}^3$$

Therefore, volume of the cylinder $= 500$ m³

9. Find the volume of the iron used to make a hollow cylinder of height 9 cm and whose internal and external radii are 21 cm and 28 cm respectively. **SEP-20**

Solution:

Let r , R and h be the internal radius, external radius and height of the hollow cylinder respectively.

Given that, $r = 21$ cm, $R = 28$ cm, $h = 9$ cm

Now, the volume of hollow cylinder

$$= \pi(R^2 - r^2) h$$

$$= \frac{22}{7} (28^2 - 21^2) \times 9 = \frac{22}{7} (784 - 441) \times 9$$

$$= \frac{22}{7} \times 343 \times 9 = 22 \times 49 \times 9 = 9702$$

Therefore, volume of iron used $= 9702$ cm³

10. The volume of a solid right circular cone is 11088 cm³. If its height is 24 cm then find the radius of the cone.

Solution:

Let r and h be the radius and height of the cone respectively.

Given that,

volume of the cone $= 11088$ cm³

$$\frac{1}{3} \pi r^2 h = 11088$$

$$\frac{1}{3} \times \frac{22}{7} \times r^2 \times 24 = 11088$$

$$r^2 = 441$$

Therefore, radius of the cone $r = 21$ cm

11. The ratio of the volumes of two cones is 2:3. Find the ratio of their radii if the height of second cone is double the height of the first.

Solution:

Let r_1 , h_1 be the radius and height of the cone I and Let r_2 , h_2 be the radius and height of the cone II.

Given that $h_2 = 2h_1$ and

$$\frac{\text{Volume of the cone I}}{\text{Volume of the cone II}} = \frac{2}{3}$$

$$\frac{r_1 h_1}{r_2 h_2} = \frac{2}{3}$$

$$\frac{r_1^2}{r_2^2} \times \frac{h_1}{2h_1} = \frac{2}{3}$$

$$\frac{r_1^2}{r_2^2} = \frac{4}{3}$$

$$\frac{r_1}{r_2} = \frac{2}{\sqrt{3}}$$

\therefore Ratio of their radii $= 2 : \sqrt{3}$

12. The volume of a solid hemisphere is 29106 cm³. Another hemisphere whose volume is two-third of the above is carved out. Find the radius of the new hemisphere.

Solution:

Let r be the radius of the hemisphere.

Given that, volume of the hemisphere =
29106 cm³

Now, volume of new hemisphere

$$= \frac{2}{3} (\text{Volume of original sphere})$$

$$= \frac{2}{3} \times 29106$$

Volume of new hemisphere

$$= 19404 \text{ cm}^3$$

$$\frac{2}{3} \pi r^3 = 19404$$

$$\frac{2}{3} \times \frac{22}{7} \times r^3 = 19404$$

$$r^3 = \frac{19404 \times 3 \times 7}{2 \times 22} = 9261$$

$$r = \sqrt[3]{9261} = 21 \text{ cm}$$

Therefore, $r = 21 \text{ cm}$

5 Marks**STAGE 2**

1. A cylindrical drum has a height of 20 cm and base radius of 14 cm. Find its curved surface area and the total surface area.

Solution:

Given that, height of the cylinder $h = 20 \text{ cm}$;
radius $r = 14 \text{ cm}$

Now, C.S.A. of the cylinder = $2\pi rh$ sq. units

$$\begin{aligned} \text{C.S.A. of the cylinder} &= 2 \times \frac{22}{7} \times 14 \times 20 \\ &= 2 \times 22 \times 2 \times 20 \\ &= 1760 \text{ cm}^2 \end{aligned}$$

T.S.A. of the cylinder = $2\pi r(h + r)$ sq. units

$$\begin{aligned} &= 2 \times \frac{22}{7} \times 14 \times (20+14) \\ &= 2 \times \frac{22}{7} \times 14 \times 34 \\ &= 2992 \text{ cm}^2 \end{aligned}$$

Therefore, C.S.A. = 1760 cm² and

$$\text{T.S.A.} = 2992 \text{ cm}^2$$

2. The internal and external radii of a hollow hemispherical shell are 3m and 5m respectively. Find the T.S.A and C.S.A. of the shell.

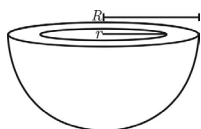
Solution:

Let the internal and external radii of the hemispherical shell be r and R respectively.

Here $R = 5 \text{ m}$, $r = 3 \text{ m}$

C.S.A of the shell = $2\pi(R^2 + r^2)$ sq. units

$$= 2 \times \frac{22}{7} (25 + 9)$$

$$= \frac{44 \times 34}{7}$$

$$= 213.71 \text{ m}^2$$

T.S.A of the shell = $\pi(3R^2 + r^2)$ sq. units

$$= \frac{22}{7} (75 + 9)$$

$$= 264 \text{ m}^2$$

Therefore, C.S.A = 213.71 m² and

$$\text{T.S.A} = 264 \text{ m}^2$$

3. 4 persons live in a conical tent whose slant height is 19 m. If each person require 22 m² of the floor area, then find the height of the tent.

Solution:

Base area of the cone = $\pi r^2 = 22 \text{ m}^2$.

4 persons living area = $4 \times 22 = 88 \text{ m}^2$

$$\pi r^2 = 88 \Rightarrow \frac{22}{7} \times r^2 = 88$$

$$r^2 = 88 \times \frac{7}{22} = 28 \text{ cm}^2$$

$$l = 19 \text{ cm} \quad l^2 = 361$$

$$h = \sqrt{l^2 - r^2} = \sqrt{361 - 28} = \sqrt{333}$$

\therefore Height of the tent = 18.25 m.

4. A girl wishes to prepare birthday caps in the form of right circular cones for her birthday party, using a sheet of paper whose area is 5720 cm², how many caps can be made with radius 5 cm and height 12 cm.

Solution:

In Cone shaped Caps $r = 5 \text{ cm}$, $h = 12 \text{ cm}$

$$\therefore l = \sqrt{h^2 + r^2} = \sqrt{12^2 + 5^2}$$

$$= \sqrt{144 + 25} = \sqrt{169} = 13 \text{ cm}$$

Let the total number of caps = n

$$n [\text{CSA}] = 5720$$

$$n [\pi r l] = 5720$$

$$n = \frac{5720}{\pi r l} = \frac{5720}{\frac{22}{7} \times 5 \times 13} = \frac{5720 \times 7}{22 \times 5 \times 13} = 28$$

\therefore Hence, the required number of caps is 28.

5. The ratio of the radii of two right circular cones of same height is 1:3. Find the ratio of their curved surface area when the height of each cone is 3 times the radius of the smaller cone.

Solution:

In cone, $r_1 : r_2 = 1:3$

$\Rightarrow r_1 = x \text{ cm}, r_2 = 3x \text{ cm}$

$h_1 : h_2 = 1:1 \Rightarrow h_1 = h_2 = h \text{ cm}$

Let $h = 3x$

$\therefore l_1 = \sqrt{r_1^2 + h^2} = \sqrt{x^2 + (3x)^2} = \sqrt{10x^2}$

$l_1 = x\sqrt{10} \text{ cm}$

$l_2 = \sqrt{r_2^2 + h^2} = \sqrt{(3x)^2 + (3x)^2}$

$l_2 = \sqrt{18x^2} = \sqrt{9 \times 2x^2} = 3\sqrt{2}x$

\therefore Ratio of their CSA

$\Rightarrow \pi r_1 l_1 : \pi r_2 l_2 = r_1 l_1 : r_2 l_2$

$\Rightarrow x(x)\sqrt{10} : (3x)(3\sqrt{2}x) = \sqrt{10} : 9\sqrt{2}$

$\Rightarrow \sqrt{2} \times \sqrt{5} : 9\sqrt{2} = \sqrt{5} : 9$

\therefore Hence Ratio of CSA of the cones is $\sqrt{5} : 9$

6. For the cylinders A and B,

(i) find out the cylinder whose volume is greater.

(ii) verify whether the cylinder with greater volume has greater total surface area.

(iii) find the ratios of the volumes of the cylinders A and B.

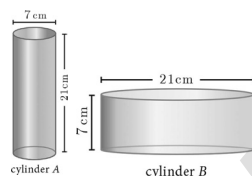

Solution:

- i) Volume of cylinder = $\pi r^2 h$ cu. units

$$\begin{aligned} \text{Volume of cylinder A} &= \frac{22}{7} \times \frac{7}{2} \times \frac{7}{2} \times 21 \\ &= 808.5 \text{ m}^3 \end{aligned}$$

$$\begin{aligned} \text{Volume of cylinder B} &= \frac{22}{7} \times \frac{21}{2} \times \frac{21}{2} \times 7 \\ &= 2425.5 \text{ cm}^3 \end{aligned}$$

Therefore, volume of cylinder B is greater than volume of cylinder A

- ii) T.S.A of cylinder = $2\pi r(h+r)$ sq. units

$$\begin{aligned} \text{T.S.A of cylinder A} &= 2 \times \frac{22}{7} \times \frac{7}{2} \times (21+3.5) \\ &= 22(24.5) \\ &= 539 \text{ cm}^2 \end{aligned}$$

T.S.A of cylinder B

$$= 2 \times \frac{22}{7} \times \frac{21}{2} \times (7+10.5) = 1155 \text{ cm}^2$$

Hence verified that cylinder B with greater volume has a greater surface area.

$$\text{iii) } \frac{\text{Volume of cylinder A}}{\text{Volume of cylinder B}} = \frac{808.5}{2425.5} = \frac{1}{3}$$

Therefore, ratio of the volumes of cylinders A and B is 1 : 3

7. Calculate the weight of a hollow brass sphere if the inner diameter is 14 cm and thickness is 1mm, and whose density is 17.3 g/cm^3 .

Solution:

Let r, R be the inner and outer radii of the hollow sphere.

Given that, inner diameter $d = 14 \text{ cm}$;

inner radius, $r = 7 \text{ cm}$,

thickness = $1 \text{ mm} = \frac{1}{10} \text{ cm}$

Outer Radius, $R = 7 + \frac{1}{10} = \frac{71}{10} = 7.1 \text{ cm}$

Volume of hollow sphere

$$= \frac{4}{3} \pi [R^3 - r^3] \text{ cu. units}$$

$$= \frac{4}{3} \times \frac{22}{7} [357.91 - 343]$$

$$= 62.48 \text{ cm}^3$$

But, weight of brass in $1 \text{ cm}^3 = 17.3 \text{ gm}$

Total weight = $17.3 \times 62.48 = 1080.90 \text{ gm}$

Therefore, total weight is 1080.90 grams

8. A cylindrical glass with diameter 20 cm has water to a height of 9 cm. A small cylindrical metal of radius 5 cm and height 4 cm is immersed it completely. Calculate the raise of the water in the glass? SEP-20

Solution:

In cylindrical glass $r_1 = 10 \text{ cm}$,

Height of water raised in the glass = h_1

In cylindrical metal $r_2 = 5 \text{ cm}, h_2 = 4 \text{ cm}$

The volume of the water raised

= Volume of the cylindrical metal

$$\pi r_1^2 h_1 = \pi r_2^2 h_2$$

$$h_1 = \frac{r_2^2 h_2}{r_1^2} = \frac{5 \times 5 \times 4}{10 \times 10} = 1$$

Hence,

the height of water raised in the glass = 1 cm

9. If the circumference of a conical wooden piece is 484 cm then find its volume when its height is 105 cm.

Solution:

Given in cone, height = 105 cm;
circumference = 484 cm

$$\Rightarrow 2\pi r = 484$$

$$\Rightarrow 2 \times \frac{22}{7} \times r = 484$$

$$r = \frac{484 \times 7}{2 \times 22}$$

$$= 77 \text{ cm}$$

$$\begin{aligned} \therefore \text{Volume of the cone} &= \frac{1}{3} \pi r^2 h \\ &= \frac{1}{3} \times \frac{22}{7} \times 77 \times 77 \times 105 \\ &= 652190 \text{ cm}^3 \end{aligned}$$

- 10.. A conical container is fully filled with petrol. The radius is 10m and the height is 15 m. If the container can release the petrol through its bottom at the rate of 25 cu. meter per minute, in how many minutes the container will be emptied. Round off your answer to the nearest minute.

Solution:

In conical container, $r = 10\text{m}$, $h = 15\text{m}$.

$$\begin{aligned} \therefore \text{Volume} &= \frac{1}{3} \pi r^2 h \\ &= \frac{1}{3} \times \frac{22}{7} \times 10 \times 10 \times 15 \\ &= 1571.43 \text{ cu.metre.} \end{aligned}$$

The petrol in the container is release at the rate of 25 cu.metre per minute.

The required time for the container will be

$$\text{emptied} = \frac{1570}{25} = 62.8 \text{ minutes } [\because T = \frac{D}{S}]$$

Hence the required time = 63 minutes

11. A right angled triangle whose sides are 6 cm, 8 cm and 10 cm is revolved about the sides containing the right angle in two ways. Find the difference in volumes of the two solids so formed.

Solution:

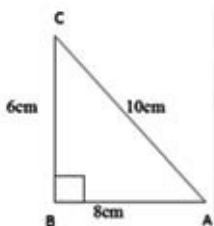

From the given, in right angled triangle ABC,
 $AB = 8$, $BC = 6$, $AC = 10$ $\angle B = 90^\circ$

When the $\triangle ABC$ is rotated about AB as axis then, We get a cone in $r = 6\text{cm}$, $h = 8\text{cm}$.

$$\begin{aligned} \text{Now, Volume} &= \frac{1}{3} \pi r^2 h \\ &= \frac{1}{3} \times \frac{22}{7} \times 6 \times 6 \times 8 \\ &= 301.71 \text{ cm}^3 \quad \text{----(1)} \end{aligned}$$

When the $\triangle ABC$ is rotated about BC as axis then, We get a cone in $r = 8\text{cm}$, $h = 6\text{cm}$.

$$\begin{aligned} \text{Now, Volume} &= \frac{1}{3} \pi r^2 h \\ &= \frac{1}{3} \times \frac{22}{7} \times 8 \times 8 \times 6 \\ &= 402.29 \text{ cm}^3 \quad \text{----(2)} \end{aligned}$$

The required difference is (2) – (1)

$$= 402.29 - 301.71 = 100.58 \text{ cm}^3$$

12. The outer and the inner surface areas of a spherical copper shell are $576\pi \text{ cm}^2$ and $324\pi \text{ cm}^2$ respectively. Find the volume of the material required to make the shell.

Solution:

The outer surface area of the sphere

$$= 576 \pi \text{ cm}^2$$

$$4\pi R^2 = 576\pi$$

$$R^2 = \frac{576}{4} = 144 \text{ cm}$$

$$R = 12 \text{ cm}$$

The inner surface area of the sphere

$$= 324 \pi \text{ cm}^2$$

$$4\pi r^2 = 324\pi$$

$$r^2 = \frac{324}{4} = 81 \text{ cm}$$

$$r = 9 \text{ cm}$$

\therefore Volume of the hollow sphere

$$= \frac{4}{3} \pi [R^3 - r^3] \text{ cu.units}$$

$$= \frac{4}{3} \times \frac{22}{7} [12^3 - 9^3]$$

$$= \frac{4}{3} \times \frac{22}{7} \times 3^3 \times (4^3 - 3^3)$$

$$= \frac{4 \times 22 \times 9}{7} \times (64 - 27) = \frac{88 \times 9 \times 37}{7}$$

$$= 4186.29 \text{ cu.cm}^3$$

Hence, the volume of the material needed is 4186.29 cu.cm^3

13. Arul has to make arrangements for the accommodation of 150 persons for his family function. For this purpose, he plans to build a tent which is in the shape of cylinder surmounted by a cone. Each person occupies 4 sq. m of the space on ground and 40 cu. meter of air to breathe. What should be the height of the conical part of the tent if the height of cylindrical part is 8 m?

Solution:



Let h_1 and h_2 be the height of cylinder and cone respectively.

Area for one person = 4 sq.m

Total number of persons = 150

Therefore, total base area = 150×4

$$\pi r^2 = 600$$

$$r^2 = 600 \times \frac{7}{22} = \frac{2100}{11} \quad \text{---- (1)}$$

Volume of air required for 1 person = 40m^3

Total Volume of air required for 150 persons

$$= 150 \times 40 = 6000 \text{ m}^3$$

$$\pi r^2 h_1 + \frac{1}{3} \pi r^2 h_2 = 6000$$

$$\pi r^2 \left(h_1 + \frac{1}{3} h_2 \right) = 6000$$

$$\frac{22}{7} \times \frac{2100}{11} \left(8 + \frac{1}{3} h_2 \right) = 6000 \quad [\text{Using (1)}]$$

$$8 + \frac{1}{3} h_2 = \frac{6000 \times 7 \times 11}{22 \times 2100}$$

$$= 10$$

$$\frac{1}{3} h_2 = 10 - 8 = 2$$

$$h_2 = 6$$

Therefore, the height of the conical tent is h_2 is 6 m

14. A funnel consists of a frustum of a cone attached to a cylindrical portion 12 cm long attached at the bottom. If the total height be 20 cm, diameter of the cylindrical portion be 12 cm and the diameter of the top of the funnel be 24 cm. Find the outer surface area of the funnel.

Solution:

Let h_1 , h_2 be the heights of the frustum and cylinder respectively.

Let R , r be the top and bottom

radii of the frustum.

Given that,

$$R = 12 \text{ cm}, r = 6 \text{ cm}, h_2 = 12 \text{ cm},$$

$$h_1 = 20 - 12 = 8 \text{ cm}$$

Slant height of the frustum

$$l = \sqrt{(R-r)^2 + h_1^2} \text{ units}$$

$$= \sqrt{36 + 64}$$

$$l = 10 \text{ cm}$$

Outer Surface Area

$$= 2\pi r h_2 + \pi(R+r)l \text{ sq.units}$$

$$= \pi(2rh_2 + (R+r)l)$$

$$= \pi(2 \times 6 \times 12) + (18)(10)$$

$$= \pi(144 + 180)$$

$$= \frac{22}{7} \times 324$$

$$= 1018.28$$

Therefore, outer surface area of the funnel is

$$1018.28 \text{ cm}^2$$

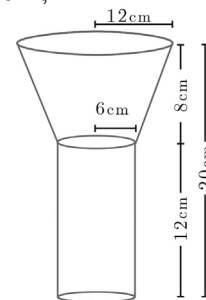

15. A vessel is in the form of a hemispherical bowl mounted by a hollow cylinder. The diameter is 14 cm and the height of the vessel is 13 cm. Find the capacity of the vessel.

Solution:

In hemisphere, $r = 7 \text{ cm}$

In cylinder, $r = 7 \text{ cm}, h = 6 \text{ cm}$

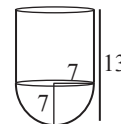

Volume of the vessel = Volume of the cylinder + Volume of hemisphere

$$= \pi r^2 h + \frac{2}{3} \pi r^3 = \pi r^2 \left(h + \frac{2}{3} r \right)$$

$$= \frac{22}{7} \times 7 \times 7 \times \left(6 + \frac{2}{3} \times 7 \right)$$

$$= 22 \times 7 \times \left[6 + \frac{14}{3} \right]$$

$$= 22 \times 7 \times \frac{32}{3}$$

$$= 1642.67 \text{ cm}^3$$

Hence, the capacity of the vessel is

$$1642.67 \text{ cm}^3$$

16. Nathan, an engineering student was asked to make a model shaped like a cylinder with two cones attached at its two ends. The diameter of the model is 3 cm and its length is 12 cm. If each cone has a height of 2 cm, find the volume of the model that Nathan made.

MAY-22

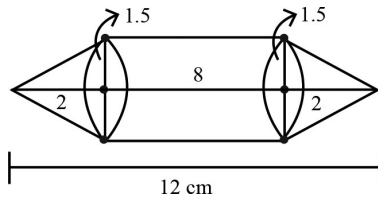
Solution:**Cylinder**

Diameter $d = 3$ cm, Radius $r = \frac{3}{2}$ cm
 Height $h_1 = 12 - (2+2) = 8$ cm

Cone

Radius $r = \frac{3}{2}$ cm, height $h_1 = 2$ cm

Volume of the model

= Volume of the cylinder + Volume of 2 cones

$$= \pi r^2 h_1 + 2 \times \frac{1}{3} \pi r^2 h_2$$

$$= \pi r^2 \left[h_1 + 2 \times \frac{1}{3} h_2 \right]$$

$$= \frac{22}{7} \times \frac{3}{2} \times \frac{3}{2} \left[8 + \frac{2}{3} \times 2 \right]$$

$$= \frac{22}{7} \times \frac{9}{4} \left[8 + \frac{4}{3} \right]$$

$$= \frac{33}{14} \left[\frac{28}{3} \right] = 66 \text{ cm}^3$$

17. From a solid cylinder whose height is 2.4 cm and the diameter 1.4 cm, a cone of the same height and same diameter is carved out. Find the volume of the remaining solid to the nearest cm^3 .

Solution:

In a solid cylinder, $r = 0.7$ cm, $h = 2.4$ cm
 and a cone carved out, its $r = 0.7$ cm,
 $h = 2.4$ cm.

Then the required volume

= Volume of the Cylinder - Volume of the Cone

$$= \pi r^2 h - \frac{1}{3} \pi r^2 h = \pi r^2 h \left(1 - \frac{1}{3} \right)$$

$$= \frac{22}{7} \times (0.7)^2 \times \frac{0.8}{3} \times \frac{2}{1}$$

$$= \frac{22}{7} \times 0.49 \times 0.8 \times 2$$

$$= \frac{22}{7} \times \frac{7}{49} \times 8 \times 2 \times \frac{1}{1000} = \frac{22 \times 7 \times 8 \times 2}{1000}$$

$$= \frac{154 \times 2}{125} = \frac{308}{125} = 2.464 \text{ cm}^3$$

Hence, the volume of the remaining solid is 2.464 cm^3

18. A solid consisting of a right circular cone of height 12 cm and radius 6 cm standing on a hemisphere of radius 6 cm is placed upright in a right circular cylinder full of water such that it touches the bottom. Find the volume of the water displaced out of the cylinder, if the radius of the cylinder is 6 cm and height is 18 cm.

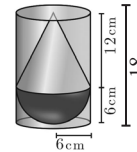
Solution:In cylinder, $r = 6$ cm, $h_1 = 18$ cm.In Cone, $r = 6$ cm, $h_2 = 12$ cm;In hemisphere, $r = 6$ cm

The required Volume

= Volume of Cone + Volume of hemisphere

$$= \frac{1}{3} \pi r^2 h_2 + \frac{2}{3} \pi r^3 = \frac{1}{3} \pi r^2 (h_2 + 2r)$$

$$= \frac{1}{3} \times \frac{22}{7} \times 6 \times 6 \times (12 + 12) = \frac{22 \times 36 \times 24}{21}$$

$$= 905.14$$

Hence, the volume of water displaced out is 905.14 cm^3

19. A capsule is in the shape of a cylinder with two hemisphere stuck to each of its ends. If the length of the entire capsule is 12 mm and the diameter of the capsule is 3 mm, how much medicine it can hold?

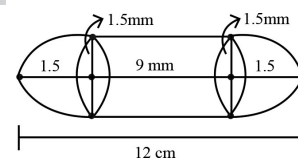
Solution:In cylindrical part, Radius = $\frac{3}{2}$ mm,

Height = 9 mm

In hemisphere part, Radius = $\frac{3}{2}$ mm

The required volume

= Volume of cylinder + (2 × Volume of hemisphere)

$$= \pi r^2 h + 2 \times \frac{2}{3} \pi r^3 = \pi r^2 \left(h + \frac{2 \times 2}{3} \times r \right)$$

$$= \frac{22}{7} \times \frac{3^2}{2^2} \times \left(9 + \frac{2 \times 2}{3} \times \frac{3}{2} \right)$$

$$= \frac{22 \times 9 \times 11}{7 \times 4} = 77.785 \text{ mm}^3$$

Hence, the volume of the medicine in the capsule can hold is 77.785 mm^3

20. A metallic sphere of radius 16 cm is melted and recast into small spheres each of radius 2 cm. How many small spheres can be obtained?

Solution:

Let the number of small spheres obtained be n .

Let r be the radius of each small sphere and R be the radius of metallic sphere.

Here, $R = 16$ cm, $r = 2$ cm

Now, $n \times (\text{Volume of a small sphere})$
= Volume of big metallic sphere

$$n \left(\frac{4}{3} \pi r^3 \right) = \frac{4}{3} \pi R^3$$

$$n \left(\frac{4}{3} \pi \times 2^3 \right) = \frac{4}{3} \pi \times 16^3$$

$$8n = 4096 \text{ gives } n = 512$$

Therefore, there will be 512 small spheres.

21. An aluminium sphere of radius 12 cm is melted to make a cylinder of radius 8 cm. Find the height of the cylinder.

Solution:

In Sphere, $r_1 = 12$ cm,

In Cylinder, $r_2 = 8$ cm

Volume of the cylinder

= Volume of sphere

$$\Rightarrow \pi r_2^2 h = \frac{4}{3} \pi r_1^3$$

$$\Rightarrow r_2^2 h = \frac{4}{3} r_1^3$$

$$\Rightarrow h = \frac{4 \times 12 \times 12 \times 12}{3 \times 8 \times 8} = 36 \text{ cm}$$

\therefore Height of the cylinder = 36 cm

22. A solid right circular cone of diameter 14 cm and height 8 cm is melted to form a hollow sphere. If the external diameter of the sphere is 10 cm, find the internal diameter.

Solution:

Diameter of the cone = 14 cm,

Radius of the cone = 7 cm,

Height of the cone $h = 8$ cm

Diameter of the sphere = 10 cm

$$\frac{4}{3} \pi (R^3 - r^3) = \frac{1}{3} \pi r^2 h$$

$$\frac{4}{3} \pi (5^3 - r^3) = \frac{1}{3} \pi \times 7 \times 7 \times 8$$

$$125 - r^3 = \frac{7 \times 7 \times 8}{4}$$

$$\Rightarrow 125 - r^3 = 98$$

$$r^3 = 27$$

$$\Rightarrow r^3 = 3^3$$

$$r = 3$$

Internal Diameter of the sphere

$$= 2(r) = 2(3) = 6 \text{ cm}$$

23. A conical flask is full of water. The flask has base radius r units and height h units, the water is poured into a cylindrical flask of base radius xr units. Find the height of water in the cylindrical flask.

Solution:

In conical flask, Radius = r , Height = h .

In Cylindrical Flask

Radius = xr , Height = h_1

Volume of water in cylindrical flask

= Volume of water in Conical Flask

$$\Rightarrow \pi (xr)^2 h_1 = \frac{1}{3} \pi r^2 h$$

$$\Rightarrow x^2 r^2 h_1 = \frac{r^2 h}{3}$$

$$\Rightarrow h_1 = \frac{r^2 h}{3x^2 r^2} = \frac{h}{3x^2}$$

\therefore The height of the water in the cylindrical flask is $\frac{h}{3x^2}$

24. Water is flowing at the rate of 15 km per hour through a pipe of diameter 14 cm into a rectangular tank which is 50 m long and 44 m wide. Find the time in which the level of water in the tanks will rise by 21 cm.

Solution:

Cylinder (Pipe) Cuboid Tank

Diameter, $R = 14$ cm Length = 50 m

Radius, $r = 7$ cm Width, $b = 44$ m

$$r = \frac{7}{100} \text{ m} \quad \text{Height, } h = \frac{21}{100} \text{ m}$$

Speed of the water

$$= 15 \text{ km/hour} = 15000 \text{ m/hour}$$

Volume of water left out from the pipe in time

$T = \text{Volume of the rectangular tank}$

Base Area \times time \times speed = $l \times b \times h$

$$\pi r^2 \times T \times \text{Speed} = l \times b \times h$$

$$\frac{11}{22} \times \frac{7}{100} \times \frac{7}{100} \times T \times 15000 = 50 \times 44 \times \frac{21}{100}$$

$$T = \frac{22 \times 21}{11 \times 7 \times 3}; T = 2 \text{ hours}$$

25. Seenu's house has an overhead tank in the shape of a cylinder. This is filled by pumping water from a sump (underground tank) which is in the shape of a cuboid. The sump has dimensions $2 \text{ m} \times 1.5 \text{ m} \times 1 \text{ m}$. The overhead tank has its radius of 60 cm and height 105 cm . Find the volume of the water left in the sump after the overhead tank has been completely filled with water from the sump which has been full, initially.

Solution:

Overhead Tank (Cylinder)

radius, $r = 60 \text{ cm}$, height, $h = 105 \text{ cm}$ Cuboid $l = 2 \text{ m} = 200 \text{ cm}$, $b = 1.5 \text{ m} = 150 \text{ cm}$, $h = 1 \text{ m} = 100 \text{ cm}$

Volume of remaining water left in sump

 $= \text{Volume of water in sump (cuboid)}$ $- \text{Volume of water Overhead tank (Cylinder)}$ $= l \times b \times h - \pi r^2 h$

$$= 200 \times 150 \times 100 - \frac{22}{7} \times 60 \times 60 \times 105$$

$$= 3000000 - 1188000$$

$$= 1812000 \text{ cm}^3 = 1812 \text{ Litres}$$

26. The internal and external diameter of a hollow hemispherical shell are 6 cm and 10 cm respectively. If it is melted and recast into a solid cylinder of diameter 14 cm , then find the height of the cylinder.

Solution:**Hollow Hemisphere**External Diameter = 10 cm ; Radius, $R = 5 \text{ cm}$ Internal Diameter = 6 cm ; Radius, $r = 3 \text{ cm}$ **Cylinder**Diameter = 14 cm Radius, $r = 7 \text{ cm}$ Height, $h = ?$

Volume of the cylinder

 $= \text{Volume of the Hollow hemisphere}$

$$\pi r^2 h = \frac{2}{3} \pi (R^3 - r^3)$$

$$\pi \times 7 \times 7 \times h = \frac{2}{3} \pi (5^3 - 3^3)$$

$$7 \times 7 \times h = \frac{2}{3} (125 - 27)$$

$$h = \frac{2}{3} \times \frac{98}{7 \times 7}$$

$$\text{Height of Cylinder, } h = \frac{4}{3} = 1.33 \text{ cm}$$

27. A solid sphere of radius 6 cm is melted into a hollow cylinder of uniform thickness. If the external radius of the base of the cylinder is 5 cm and its height is 32 cm , then find the thickness of the cylinder.

Solution:**Sphere**Radius, $r = 6 \text{ cm}$

Hollow Cylinder

External Radius $R = 5 \text{ cm}$,height, $h = 32$, $r = ?$

Volume of hollow cylinder

 $= \text{volume of sphere}$

$$\pi(R^2 - r^2)h = \frac{4}{3} \pi r^3$$

$$\pi(5^2 - r^2)32 = \frac{4}{3} \pi \times 6 \times 6 \times 6$$

$$(25 - r^2) = \frac{4 \times 6 \times 6 \times 6}{3 \times 32}$$

$$25 - r^2 = 9 \Rightarrow 25 - 9 = r^2$$

$$\Rightarrow r^2 = 16 \Rightarrow r = 4$$

Thickness of Cylinder

$$= R - r = 5 - 4 = 1 \text{ cm}$$

8

Statistics and Probability

5 Marks

STAGE 2

1. Find the coefficient of variation of 24, 26, 33, 37, 29, 31.

Solution:

x	$d = x - \bar{x}$	d^2
24	-6	36
26	-4	16
33	3	9
37	7	49
29	-1	1
31	1	1
180	$\Sigma d = 0$	112

$$\text{Mean} = \bar{x} = \frac{\Sigma x}{n} = \frac{180}{6} = 30$$

Standard Deviation,

$$\sigma = \sqrt{\frac{\Sigma d^2}{n}} = \sqrt{\frac{112}{6}} = \sqrt{18.66} = 4.32$$

Coefficient of Variation

$$\begin{aligned} &= \frac{\sigma}{\bar{x}} \times 100\% = \frac{4.32}{30} \times 100\% \\ &= 14.4\% \end{aligned}$$

2. The time taken (in minutes) to complete a homework by 8 students in a day are given by 38, 40, 47, 44, 46, 43, 49, 53. Find the coefficient of variation.

Solution:

Arranging the numbers in ascending order we get 38, 40, 43, 44, 46, 47, 49, 53

x	$d = x - \bar{x}$	d^2
38	-7	49
40	-5	25
43	-2	4
44	-1	1
46	1	1
47	2	4
49	4	16
53	8	64
360	$\Sigma d = 0$	164

$$\text{Mean} = \bar{x} = \frac{\Sigma x}{n} = \frac{360}{8} = 45$$

Standard Deviation,

$$\sigma = \sqrt{\frac{\Sigma d^2}{n}} = \sqrt{\frac{164}{8}} = \sqrt{20.5} = 4.527$$

Coefficient of Variation

$$= \frac{\sigma}{\bar{x}} \times 100\% = \frac{4.527}{45} \times 100\% = 10.07\%$$

3. A coin is tossed thrice. Find the probability of getting exactly two heads or atleast one tail or two consecutive heads.

Solution:

$$S = \{HHH, HHT, HTH, THH, TTT, TTH, THT, HTT\}$$

$$n(S) = 8$$

A = Exactly 2 Heads

$$A = \{HHT, HTH, THH\}$$

$$n(A) = 3$$

$$\Rightarrow P(A) = \frac{3}{8}$$

B = Atleast one tail

$$B = \{HHT, HTH, THH, TTT, TTH, THT, HTT\}$$

$$n(B) = 7$$

$$\Rightarrow P(B) = \frac{7}{8}$$

C = Consecutively 2 heads

$$C = \{HHH, HHT, THH\}$$

$$n(C) = 3 \Rightarrow P(C) = \frac{3}{8}$$

$$P(A \cap B) = \frac{3}{8}; \quad P(B \cap C) = \frac{2}{8}$$

$$P(A \cap C) = \frac{2}{8}; \quad P(A \cap B \cap C) = \frac{2}{8}$$

$$P(A \cup B \cup C) = P(A) + P(B) + P(C) - P(A \cap B) - P(B \cap C) - P(A \cap C) + P(A \cap B \cap C)$$

$$= \frac{3}{8} + \frac{7}{8} + \frac{3}{8} - \frac{3}{8} - \frac{2}{8} - \frac{2}{8} + \frac{2}{8}$$

$$= \frac{15-7}{8} = \frac{8}{8} = 1$$

4. A flower is selected at random from a basket containing 80 yellow, 70 red and 50 white flowers. Find the probability of selecting a yellow or red flower?

Solution:

Total number of flowers

$$n(S) = 80 + 70 + 50 = 200$$

No. of yellow flowers $n(Y) = 80$

$$\therefore P(Y) = \frac{n(Y)}{n(S)} = \frac{80}{200}$$

No. of red flowers $n(R) = 70$

$$\therefore P(R) = \frac{n(R)}{n(S)} = \frac{70}{200}$$

Y and R are mutually exclusive

$$P(Y \cup R) = P(Y) + P(R)$$

Probability of drawing either a yellow or red flower

$$P(Y \cup R) = \frac{80}{200} + \frac{70}{200} = \frac{150}{200} = \frac{3}{4}$$

5. In an apartment, in selecting a house from door numbers 1 to 100 randomly, find the probability of getting the door number of the house to be an even number or a perfect square number or a perfect cube number.

Solution:

Total number of houses $n(S) = 100$

Let A be the event of getting door number even.

$$A = \{2, 4, 6, 8, \dots, 100\}$$

$$n(A) = 50$$

$$\therefore P(A) = \frac{n(A)}{n(S)} = \frac{50}{100}$$

Let B be the event of getting door number perfect square

$$A = \{1, 4, 9, 16, 25, 36, 49, 64, 81, 100\}$$

$$n(A) = 10$$

$$\therefore P(A) = \frac{n(B)}{n(S)} = \frac{10}{100}$$

Let C be the event of getting door number perfect cube

$$A = \{1, 8, 27, 64\}$$

$$n(A) = 4$$

$$\therefore P(A) = \frac{n(C)}{n(S)} = \frac{4}{100}$$

$$P(A \cap B) = P$$

$$\text{(getting even perfect square number)} = \frac{5}{100}$$

$$P(B \cap C) = P$$

$$\text{(getting even perfect square and perfect cube number)} = \frac{2}{100}$$

$$P(A \cap C) = P$$

$$\text{(getting even perfect cube number)} = \frac{2}{100}$$

$$P(A \cap B \cap C) = P$$

$$\text{(getting even perfect square and perfect cube number)} = \frac{1}{100}$$

Required probability

$$\begin{aligned} P(A \cup B \cup C) &= P(A) + P(B) + P(C) - P(A \cap B) - \\ &P(B \cap C) - P(A \cap C) + P(A \cap B \cap C) \\ &= \frac{50}{100} + \frac{10}{100} + \frac{4}{100} - \frac{5}{100} - \frac{2}{100} - \frac{2}{100} + \frac{1}{100} \\ &= \frac{65}{100} - \frac{9}{100} = \frac{56}{100} = \frac{14}{25} \end{aligned}$$

6. If A, B, C are any three events such that probability of B is twice as that of probability of A and probability of C is thrice as that of probability of A and if $P(A \cap B) = \frac{1}{6}$, $P(B \cap C) = \frac{1}{4}$, $P(A \cap C) = \frac{1}{8}$, $P(A \cup B \cup C) = \frac{9}{10}$, $P(A \cap B \cap C) = \frac{1}{15}$, then find $P(A)$, $P(B)$ and $P(C)$?

Solution:

$$P(B) = 2 P(A) \quad \dots (1)$$

$$\text{Let } P(C) = 3 P(A) \quad \dots (2)$$

$$\text{and } P(A \cap B) = \frac{1}{6},$$

$$P(B \cap C) = \frac{1}{4}, P(A \cap C) = \frac{1}{8},$$

$$P(A \cup B \cup C) = \frac{9}{10}, P(A \cap B \cap C) = \frac{1}{15}$$

$$\Rightarrow P(A \cup B \cup C) = P(A) + P(B) + P(C) - P(A \cap B) - P(B \cap C) - P(A \cap C) + P(A \cap B \cap C)$$

$$\Rightarrow \frac{9}{10} = P(A) + 2P(A) + 3P(A) - \frac{1}{6} - \frac{1}{4} - \frac{1}{8} + \frac{1}{15}$$

$$\Rightarrow \frac{9}{10} = 6P(A) - \left(\frac{4+6+3}{24} \right) + \frac{1}{15}$$

$$\Rightarrow \frac{9}{10} = 6P(A) - \frac{13}{24} + \frac{1}{15}$$

$$\Rightarrow 6P(A) = \frac{9}{10} + \frac{13}{24} - \frac{1}{15}$$

$$\Rightarrow 6P(A) = \frac{216-16+130}{240}$$

$$= \frac{330}{240} = \frac{33}{24} = \frac{11}{8}$$

$$\Rightarrow P(A) = \frac{11}{8} \times \frac{1}{6}; P(A) = \frac{11}{48}$$

$$(1) \Rightarrow P(B) = 2 \times \frac{11}{48} = \frac{11}{24}$$

$$(2) \Rightarrow P(C) = 3 \times \frac{11}{48} = \frac{11}{16}$$

$$\therefore P(A) = \frac{11}{48}, P(B) = \frac{11}{24}, P(C) = \frac{11}{16}$$

GOVT QUESTION PAPER - APRIL 2023

CLASS: X

MATHEMATICS

Time allowed: 3.00 Hours

Maximum Marks: 100

Instructions : 1. Check the question paper for fairness of printing. If there is any lack of fairness inform the hall supervisor immediately.

2. Use Blue or Black ink to write and underline and pencil to draw diagrams.

Note: This question paper contains **four** parts.

PART - I

Note : (i) Answer all the questions.

14×1=14

(ii) Choose the most appropriate answer from the given four alternatives and write the option code and the corresponding answer.

- $A = \{a, b, p\}$, $B = \{2, 3\}$, $C = \{p, q, r, s\}$ then $n[A \cup B] \times B$ is:
a) 8 b) 20 c) 12 d) 16
- If $n(A) = p$, $n(B) = q$, then the total number of relations that exist from A to B is _____.
a) 0 b) 1 c) $2^{pq} - 1$ d) 2^{pq}
- Given $F_1 = 1$, $F_2 = 3$ and $F_n = F_{n-1} + F_{n-2}$ then, F_5 is:
a) 3 b) 5 c) 8 d) 11
- If the sequence t_1, t_2, t_3, \dots are in A.P., then the sequence $t_6, t_{12}, t_{18}, \dots$ is:
a) a Geometric Progression b) an Arithmetic Progression
c) neither an Arithmetic Progression nor a Geometric Progression d) a constant sequence
- $\frac{3y-3}{y} \div \frac{7y-7}{3y^2}$ is :
a) $\frac{9y}{7}$ b) $\frac{9y^3}{(21y-21)}$ c) $\frac{21y^2 - 42y + 21}{3y^3}$ d) $\frac{7(y^2 - 2y + 1)}{y^2}$
- Graph of a Quadratic equation is a _____.
a) straight line b) circle c) parabola d) hyperbola
- If in triangle ABC and EDF, $\frac{AB}{DE} = \frac{BC}{FD}$ then they will be similar, when:
a) $\underline{|B|} = \underline{|E|}$ b) $\underline{|A|} = \underline{|D|}$ c) $\underline{|B|} = \underline{|D|}$ d) $\underline{|A|} = \underline{|F|}$
- A tangent of a circle is perpendicular to the radius at the :
a) centre b) point of contact c) infinity d) chord
- The slope of the straight line perpendicular to x-axis is :
a) 1 b) 0 c) ∞ d) -1
- If $\sin\theta = \cos\theta$, then the value of $2\tan^2\theta + \sin^2\theta - 1$ is:
a) $\frac{3}{2}$ b) $-\frac{3}{2}$ c) $\frac{2}{3}$ d) $-\frac{2}{3}$
- The height of a right circular cone whose radius is 5 cm and slant height is 13 cm will be:
a) 12 cm b) 10 cm c) 13 cm d) 5 cm
- The ratio of the volumes of a cylinder, a cone and a sphere, if each has the same diameter and same height is:
a) 1 : 2 : 3 b) 2 : 1 : 3 c) 1 : 3 : 2 d) 3 : 1 : 2
- If the sum and mean of a data are 407 and 11 respectively, then the number of observations in the data are:
a) 37 b) 4477 c) 396 d) 418

14. If a letter is chosen at random from the English alphabets (a, b,, z), then the probability that the letter chosen precedes x:

a) $\frac{12}{13}$

b) $\frac{1}{13}$

c) $\frac{23}{26}$

d) $\frac{3}{26}$

PART - II

Note : Answer any 10 questions. Question No. 28 is compulsory.

10×2=20

15. $B \times A = \{(-2, 3), (-2, 4), (0, 3), (0, 4), (3, 3), (3, 4)\}$ find A and B.

16. Find k if $f \circ f(k) = 5$ where $f(k) = 2k - 1$.

17. Find x so that $x + 6$, $x + 12$ and $x + 15$ are consecutive terms of a Geometric Progression.

18. Simplify: $\frac{x+2}{4y} \div \frac{x^2-x-6}{12y^2}$

19. Determine the nature of roots for the following quadratic equation. $2x^2 - x - 1 = 0$

20. In the figure AD is the bisector of $\angle BAC$, if $AB = 10$ cm, $AC = 14$ cm and $BC = 6$ cm. Find BD and DC.

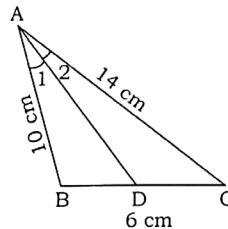

21. A cat is located at the point $(-6, -4)$ in xy plane. A bottle of milk is kept at $(5, 11)$. The cat wishes to consume the milk travelling through shortest possible distance. Find the equations of the path it needs to take the milk.

22. If the straight lines $12y = -(P+3)x+12$, $12x-7y = 16$ are perpendicular then find 'P'.

23. Prove that $\frac{\sec \theta}{\sin \theta} - \frac{\sin \theta}{\cos \theta} = \cot \theta$

24. The radius of a conical tent is 7 m and height is 24 m. Calculate the length of the canvas used to make the tent if the width of the rectangular canvas is 4 m.

25. If the ratio of radii of two spheres is $4 : 7$, find the ratio of their volumes.

26. Find the range and co-efficient of range of the following data.

63, 89, 98, 125, 79, 108, 117, 68.

27. A and B are two candidates seeking admission to IIT. The probability that a getting selected is 0.5 and the probability that both A and B getting selected is 0.3. Prove that probability of B being selected is at the most 0.8.

28. If $p^2 \times q^1 \times r^4 \times s^3 = 3,15,000$ then find p, q, r and s.

PART - III

Note : Answer any 10 questions. Question No. 42 is compulsory.

10×5=50

29. $f: A \rightarrow B$ be a function defined by $f(x) = \frac{x}{2} - 1$, where $A = \{2, 4, 6, 10, 12\}$, $B = \{0, 1, 2, 4, 5, 0\}$
Represent f by:

(i) set of ordered pairs (ii) a table (iii) an arrow diagram (iv) a graph

30. The houses of a street are numbered from 1 to 49. Senthil's house is numbered such that the sum of numbers of the houses prior to Senthil's house is equal to the sum of numbers of the houses following Senthil's house. Find Senthil's house number.

31. Find the sum to n terms of the series $5 + 55 + 555 + \dots$

32. Solve the following system of linear equations in three variables.

$$x + 20 = \frac{3y}{2} + 10 = 2z + 5 = 110 - (y+z)$$

33. $A = \begin{pmatrix} 5 & 2 & 9 \\ 1 & 2 & 8 \end{pmatrix}$, $B = \begin{pmatrix} 1 & 7 \\ 1 & 2 \\ 5 & -1 \end{pmatrix}$ verify that $(AB)^T = B^T A^T$

34. Two poles of height 'a' metres and 'b' metres are 'P' metres apart. Prove that the height of the point of intersection of the lines joining the top of each pole to the foot of the opposite pole is given by $\frac{ab}{a+b}$ metres.

35. State and prove Angle Bisector theorem.

36. Find the area of the quadrilateral formed by points (8, 6), (5, 11), (-5, 12) and (-4, 3).

37. Find the equation of a straight line parallel to X-axis and passing through the point of intersection of the lines $7x - 3y = 12$ and $2y = x + 3$.

38. From the top of a lighthouse, the angle of depression of two ships on the opposite sides of it are observed to be 30° and 60° . If the height of the lighthouse is 'h' metres and the line joining the ships passes through the foot of the lighthouse. Show that the distance between the ships is $\frac{4h}{\sqrt{3}}$ m.

39. The radius and height of a cylinder are in the ratio 5 : 7 and its curved surface area is 5500 sq.cm. Find its radius and height.

40. Arul has to make arrangements for the accommodation of 150 persons for his family function. For this purpose, he plans to build a tent which is in the shape of cylinder surmounted by a cone. Each person requires 4 sq.m of the space on ground and 40 cu.meter of air to breathe. Find the height of the conical part of the tent if the height of cylindrical part is 8 m.

41. Two unbiased dice are rolled come. Find the probability of getting:

- a doublet (equal numbers on both dice)
- the product as a prime number
- the sum as a prime number
- the sum as 1

42. Let $A = \{x \in W/x < 3\}$, $B = \{x \in N/1 < x \leq 5\}$ and $C = \{3, 5, 7\}$ verify that $A \times (B \cup C) = (A \times B) \cup (A \times C)$.

PART - IV

Note : Answer all the questions.

2×8=16

43. a) Take a point which is 11 cm away from the centre of a circle of radius 4 cm and draw two tangents to the circle from that point.

(OR)

b) Draw a triangle ABC of base BC = 8 cm, $\angle A = 60^\circ$ and the bisector of $\angle A$ meets BC and D such that BD = 6 cm.

44. a) Varshika drew 6 circles with different sizes. Draw a graph for the relationship between the diameter and circumference (approximately related) of each circle as shown in the table and use it to find the circumference of a circle when its diameter is 6 cm.

Diameter (x) cm	1	2	3	4	5
Circumference (y)cm	3.1	6.2	9.3	12.4	15.5

(OR)

b) Draw the graph of $y = x^2 - 5x - 6$ and hence solve $x^2 - 5x - 14 = 0$
